

E. S. MAY.  
 Pocket-Case for Pipe and Tobacco.

No. 203,058.

Patented April 30, 1878.

Fig. 1.

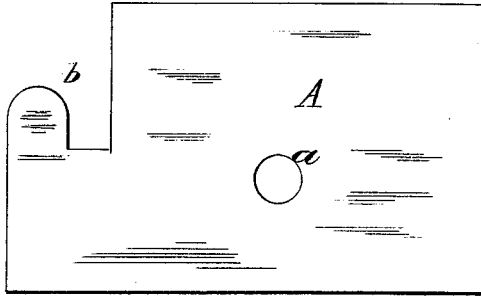

Fig. 2.

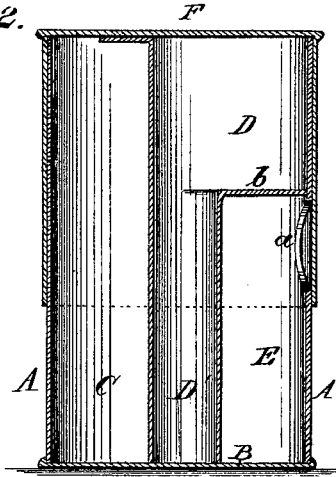

Fig. 1<sup>A</sup>.



Fig. 3.

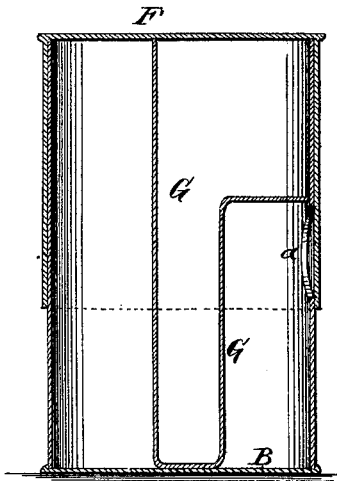

Fig. 4.

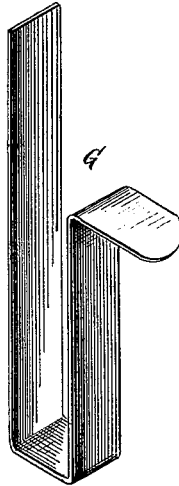
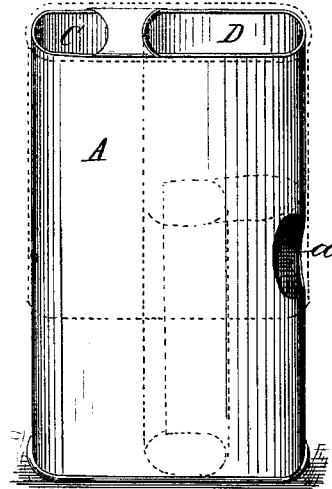

Fig. 5.



Witnesses

Edw. J. Dittreich

August Petersohn

Inventor:  
 Edward S. May  
 by: C. A. Snow & Co.  
 attorneys.

# UNITED STATES PATENT OFFICE.

EDWARD S. MAY, OF CAMPBELLTOWN, NEW YORK.

## IMPROVEMENT IN POCKET-CASES FOR PIPE AND TOBACCO.

Specification forming part of Letters Patent No. 203,058, dated April 30, 1878; application filed February 27, 1878.

*To all whom it may concern:*

Be it known that I, EDWARD S. MAY, of Campbelltown, in the county of Steuben and State of New York, have invented certain new and useful Improvements in Smokers' Combination-Cases; and I do hereby declare that the following is a full, clear, and exact description thereof, which will enable others skilled in the art to which it appertains to make and use the same, reference being had to the accompanying drawings, which form a part of this specification, and in which—

Figure 1 is a plan view of the blank used, preferably, for the manufacture of my combination-case. Fig. 1<sup>a</sup> is a top view of the blank as coiled in the process of manufacturing the case. Fig. 2 is a vertical section of the case made from the blank represented in Fig. 1. Fig. 3 is a similar section of a case like the case shown in Fig. 2, but differently constructed. Fig. 4 is a perspective view of the partition-blank inserted into the case shown in Fig. 3 to form the compartments; and Fig. 5 is a perspective view of the complete case.

Similar letters of reference indicate corresponding parts in all the figures.

My invention consists in the construction of a case adapted to be a convenient receptacle for tobacco, pipe, and matches, and having several peculiarly-arranged compartments for these articles, substantially as hereinafter more fully described.

My case, which I call a "smoker's combination-case," may be made in several ways; but I prefer to make it from a blank of sheet metal, leather, pasteboard, or other suitable material, cut into the shape shown in Fig. 1, having a hole, *a*, and a flap or tongue, *b*. This blank is bent or rolled as represented in Fig. 1<sup>a</sup>, after which tongue *b* is bent down at a right angle, as shown in Fig. 2. A bottom piece, B, is then inserted, and a cover made to fit over the top of the case, which should reach a sufficient distance down to cover the match-opening *a*. In this manner three compartments are formed, denoted by C, D, and E, respectively, the last of which, E, is inclosed by the

bottom piece B, tongue *b*, (which form the bottom and top,) and blank A, which forms the sides. C is intended to hold the tobacco, and may be covered or closed by a separate hinged cover, if desired. D is a receptacle for the pipe, the stem of which will project down into the tubular part D', while the bowl rests in the upper enlarged part over the match-box E, from which the matches may be drawn out through the opening *a*, but are prevented from falling out of their own accord by the cover F.

In Fig. 3 I have shown a case having the same number and arrangement of compartments, but differently constructed. In this case the compartments are formed by inserting into the outer shell a division-piece, G, made by bending a strip of sheet metal or other suitable material into the shape shown in Fig. 4, and then inserting this piece into the case and securely fastening it there, as shown in Fig. 3.

This case, whether constructed as represented in Figs. 1 and 2, or as in Figs. 3 and 4, affords a convenient smoker's companion, occupying but little space, and always handy and ready for use.

If made sufficiently large, the top or cover F may be used as a drinking-cup.

This case may be made in different sizes, and of different material, suitably ornamented, if desired.

Having thus described my invention, I claim and desire to secure by Letters Patent of the United States—

The smoker's case herein shown and described, having the compartments C, D, and E, arranged as described, match-opening *a*, and cover F, substantially as and for the purpose hereinbefore set forth.

In testimony that I claim the foregoing as my own I have hereto affixed my signature in presence of two witnesses.

EDWARD S. MAY.

Witnesses:

SOLOMON A. CASS,  
CHARLES CASS.