

J. BULLOCK. Machine for Winding Bobbins.

No. 203,114.

Patented April 30, 1878.

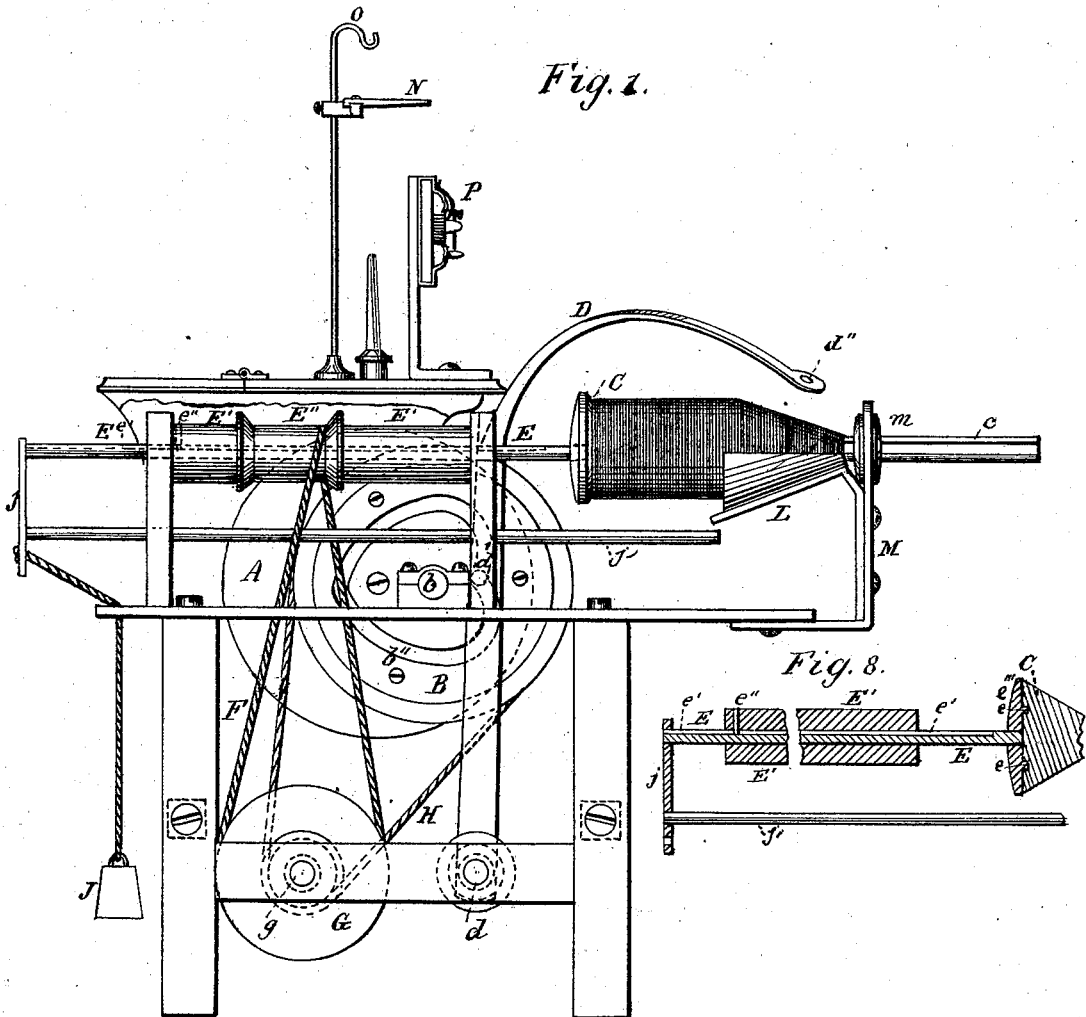

Fig. 1.

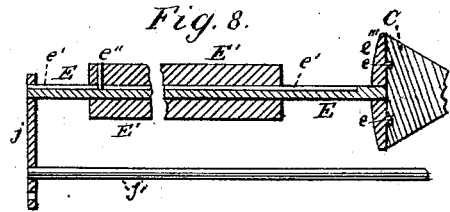

Fig. 8.

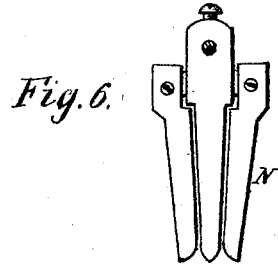

Fig. 6.

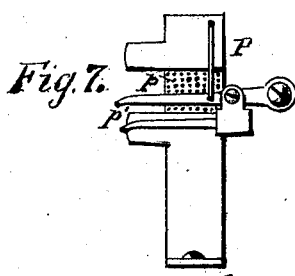

Fig. 7.

WITNESSES

J. A. Tauberschmidt
P. Merrick.

INVENTOR

Joseph Bullock
by L. Deane,

ATTORNEY

J. BULLOCK.
Machine for Winding Bobbins.

No. 203,114.

Patented April 30, 1878.

Fig. 2.

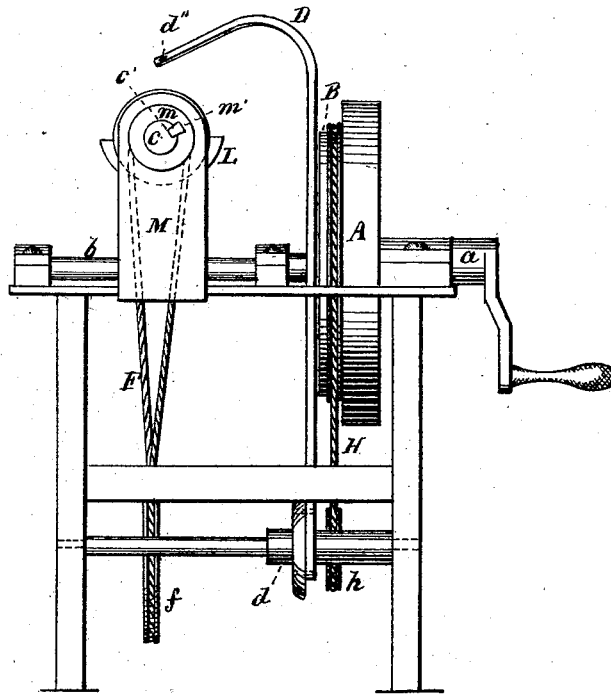

Fig. 3.

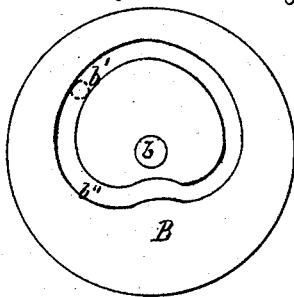

Fig. 4.

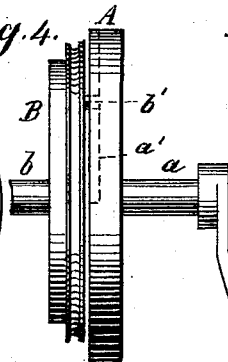
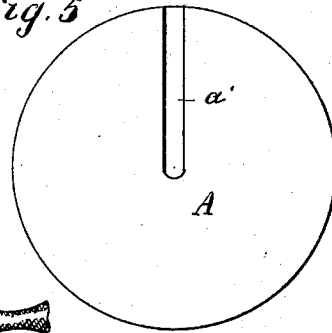

Fig. 5.



WITNESSES

J. A. Tauberschmidt
P. McKie.

INVENTOR

Joseph Bullock.
by L. Deane.

ATTORNEY

UNITED STATES PATENT OFFICE.

JOSEPH BULLOCK, OF COHOES, NEW YORK, ASSIGNOR, BY MESNE ASSIGNMENTS, TO JOSEPH BULLOCK, TRUSTEE.

IMPROVEMENT IN MACHINES FOR WINDING BOBBINS.

Specification forming part of Letters Patent No. 203,114, dated April 30, 1878; application filed July 9, 1877.

To all whom it may concern:

Be it known that I, JOSEPH BULLOCK, of the city of Cohoes, in the county of Albany and State of New York, have invented certain new and useful Improvements in Machines for Winding Bobbins, of which the following is a specification:

Figure 1 is a side elevation, with some parts broken away to show the mechanism. Fig. 2 is an end elevation. Fig. 3 is a side elevation of pulley having the heart-cam. Fig. 4 is an end elevation, showing edges of larger pulley-wheel and the cam-pulley. Fig. 5 is a side view of large wheel, cam-pulley removed. Fig. 6 is a plan of stripper. Fig. 7 is a plan of auxiliary cleaner. Fig. 8 is a sectional detail of spindle actuating the bobbin.

My invention relates to that class of bobbin-winding machines in which the bobbin is given a varied speed, according to the varying circumference of the filling; and it consists, mainly, in the peculiar method of obtaining the varied motion; in the use of a novel method of supporting the stem of the bobbin, whereby the working revolving surface supporting the stem can be readily lubricated without damage to the yarn; in the peculiar construction of the bobbin to adapt it to be used with the above-mentioned support; in a new arrangement of the stripper, whereby the tension is made more even, and in the novel construction of an auxiliary cleaner, all of which will be found fully set forth in the following description.

In the accompanying drawings, A denotes a grooved face-plate, the periphery of which may be used as a pulley, which has motion on its axis *a*. This face-plate is so fixed that it sets face to face with another face-plate or pulley, B, which revolves on its axis *b*, but takes its motion from face-plate A, through a stud, *b'*, on the inner face of B, playing in the groove *a'* on the inner face of A, and extending from center to circumference.

The shaft *b* is set on one side of the shaft *a*, so that as the face-plates A and B revolve the stud *b'* approaches and recedes from the center of the face-plate A, and as the

central portion of this face-plate travels relatively slower than its circumference the face-plate B must have a varied motion imparted to it, which will change with the distance of the stud *b* from the center of the face-plate A. The irregular motion will bear a direct relation to the center position of the stud and of the axes *a b*, and is now so adjusted that the bobbin C, which is intended to be about four times as large in diameter at its base as at its smaller end, will revolve four times as fast at the apex of the cone, when receiving the thread, as it does at the base when receiving the thread there.

A bobbin-former is represented at L attached to the support M, which support also carries an annular flanged bearing, *m*, so arranged as to revolve freely therein. In said bearing *m* is a pin, *m'*, projecting into a longitudinal groove, *c'*, on the stem of the bobbin. By this arrangement of the bobbin and the bearing, the former can be run at great speed with comparatively little friction, as all the revolving friction occurs between the bearing and the support M, which can be readily lubricated without the soiling of the yarn. This not only allows of solid-stemmed bobbins being used, but affords a means of decreasing the friction at the extremities of the stems by lubrication. This has never before been accomplished with solid-stemmed bobbins, which have many advantages, as they not only allow the winding of a larger amount of yarn on them, because the size of the stems may be decreased, but are cheaper than the hollow-stemmed bobbins, and not so liable to split. In the opposite end of the bobbin are holes to receive pins *e* on the end of spindle E or its boss *e''*. Thus the bobbin will take its motion from the spindle.

The thread-guide D is pivoted at its lower end *d*, and adapted to be moved by means of stud *d'*, which plays in the heart-cam *b''* on the outer face of pulley B. This guide is so adjusted relatively to the bobbin that its end *d''*, carrying the thread to the bobbin, supplies the thread at the base when the bobbin is turning slowest, and as the speed of the

bobbin gradually increases the guide carries the thread forward toward the apex of the bobbin. Thus the bobbin receives five turns of the thread from the base to the apex, and the same number in reverse movement, or ten in all, for each revolution of the large pulley.

The spindle E, which revolves the bobbin, has a longitudinal groove, *e'*, in its surface, in which plays the pin *e''* on the inside of the sleeve E', through which this spindle passes, and thus imparts rotary motion to said spindle. This sleeve is revolved by belt F, which passes over drum E'' of said sleeve, and pulley G, mounted on shaft *g*, and revolved by means of belt H, which passes over its wheel *h*, and is moved by the cam wheel or pulley B.

The weight J, acting on the end of spindle E by means of arm *j*, keeps the bobbin in place, but is not so heavy but that the bobbin, as it fills, may press back sufficiently. The movable guide *j'* regulates its motion. The stripper N is placed so as to act on the thread before it passes over the friction-bar O. In this position the shaking or vibrating motion of the thread as it comes from a cop, jack, bobbin, or skein acts in such a way as to keep the stripper N from being clogged with seeds or dirt, and allows it to act in a more perfect manner. This position not only keeps the stripper clean by allowing the seeds, dirt, lint, &c., to fall down, but by cleaning the thread before it passes to the friction-bar O, the tension on it is more regular and even than when the thread has knots, seeds, dirt, &c., on it as it passes over the friction-bar.

For the purpose of assisting the stripper, I have devised a new auxiliary cleaner, P, which consists of a series of wire points, *p*, in the shape of ordinary card-clothing or its equivalent, set at a suitable distance from a solid surface, *p'*. Over this card-clothing or wire points the yarn passes freely as long as there are no inequalities; but if a rough place or other imperfection resents itself the points arrest and break the thread.

The operation of the machine may be described as follows: Place the base of the bobbin against the boss *e'''* of the spindle E, and press it backward until the stem of the bobbin can be inserted in the annular bearing *m*, after which allow the weight J to force the cone of the bobbin against the former L. Then pass the yarn through the eye *d''* in the thread-guide D, and secure it to the cone of the bobbin. Motion is then given to the machine in any convenient manner, and the revolution of the face-plate or pulley A will, by means of the groove *a'* and stud *b'*, give the required varied motion to the other pulley or face-plate B, which is transferred, by means of the pulleys G *h*, belts F H, drum E'', sleeve E', and spindle E, to the bobbin C. At the same time the heart-cam will give the necessary vibrating motion to the guide D, and the combination of these two motions will cause a layer of yarn to be wound evenly

on the cone of the bobbin, which layer, as it accumulates between the cone and former L, forces the bobbin backward against the pressure of weight J, and so makes room for an additional layer, which the next turn of the face-plate or pulley A winds on that previously wound on the cone. A continuation of the rotary motion of the face-plate A will, in this manner, successively wind a series of conical layers of yarn on the bobbin, each of which, and every part thereof, will be laid with the greatest regularity, both as to coils and tension.

The thread-stripper before referred to consists of two or more plates adjustable, relatively to each other, so that the distance between them may be increased or diminished, according to the size of the yarn that is to be passed between them. The stripper so formed allows the yarn to pass through as long as no obstructions present themselves, but breaks the yarn whenever necessary on account of unevenness in the thread, of cotton-seeds, knots, or any of the well-known reasons for which the winding should cease until the obstruction is removed.

I am aware that it is not new to use a longitudinally-grooved shaft sliding in an annular bearing, nor to mount a perforated bobbin on a separate shaft, which shaft is fixed in an annular bearing so arranged that both shaft and bearing revolve together without the shaft sliding in the bearing, and that the idea of causing a bobbin to both slide and revolve in a fixed bearing is old; but none of these cases show a bobbin adapted to revolve in and with an annular bearing to reduce the friction on the extremity of the bobbin, and yet so arranged as to allow it to readily slide backward as it becomes filled, nor do any of them show a solid bobbin fitted direct to an annular bearing, either sliding therein or fixed.

Having thus described my invention, what I consider new, and desire to secure by Letters Patent, is—

1. The combination, in a bobbin-winding machine, of the face-plates A and B—one having a stud to work in a slot in the other—with a cam, *b''*, and yarn-guide D, substantially as described, and for the purpose set forth.

2. The combination of a sliding bobbin with an annular bearing, *m*, arranged substantially as described, to allow the bobbin to move freely in the bearing and yet compel the two to revolve together, in the manner set forth, and for the purpose specified.

3. The combination of the stripper N with the friction-bar O, the two being arranged substantially as described, so as to trim the yarn before it passes over any frictional surface, for the purpose specified.

4. The auxiliary cleaner P, provided with one or more plane surfaces and a series of wire points, for the purpose specified.

5. The combination of the support M, spin-

dle E, sliding bobbin C, and annular bearing
m, arranged substantially as described, where-
by the bobbin is allowed to move freely
through the annular bearing and yet carry
said bearing with it in its revolution, for the
purpose set forth.

In testimony that I claim the foregoing as

my own I affix my signature in presence of
two witnesses.

JOSEPH BULLOCK.

Witnesses:

J. P. CRAWFORD,
LAURENCE B. FLINN.