

S. B. DAVIS.
Seed-Planter.

No. 203,122.

Patented April 30, 1878.

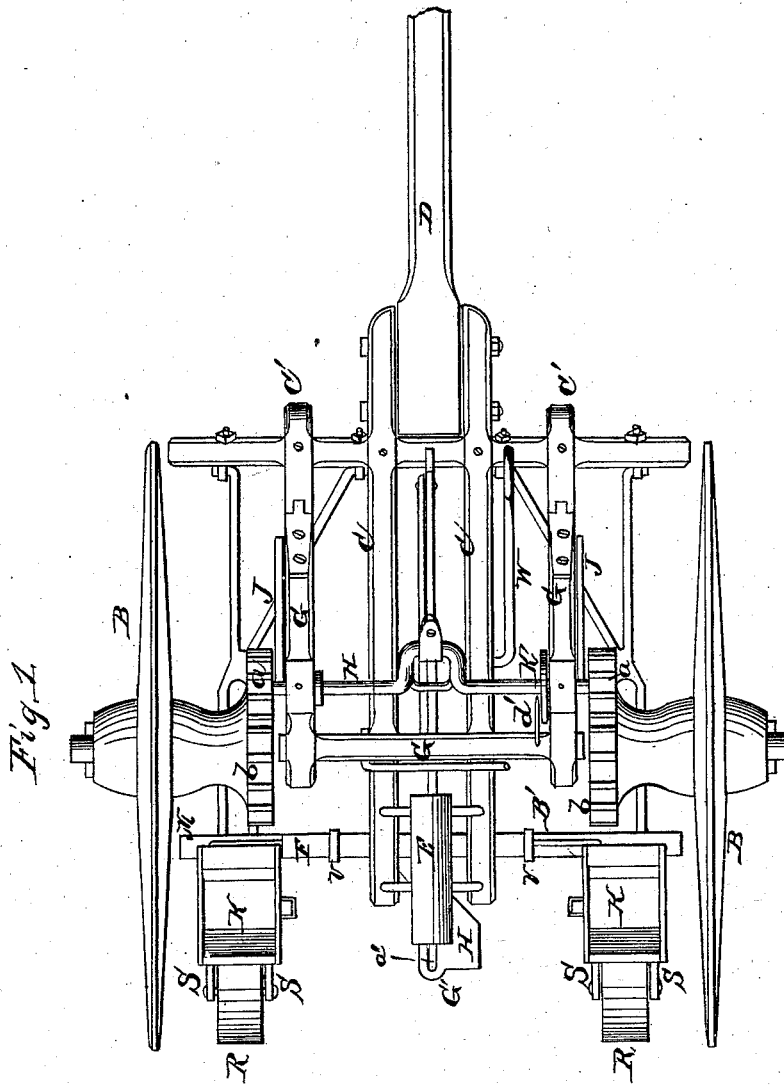

Fig. 1

Witnesses:
H. C. M. Arthur
C. S. Evans

Inventor:
Samuel B. Davis
 per
S. H. Alexander & Elliott
 Attorneys.

S. B. DAVIS.
Seed-Planter.

No. 203,122.

Patented April 30, 1878.

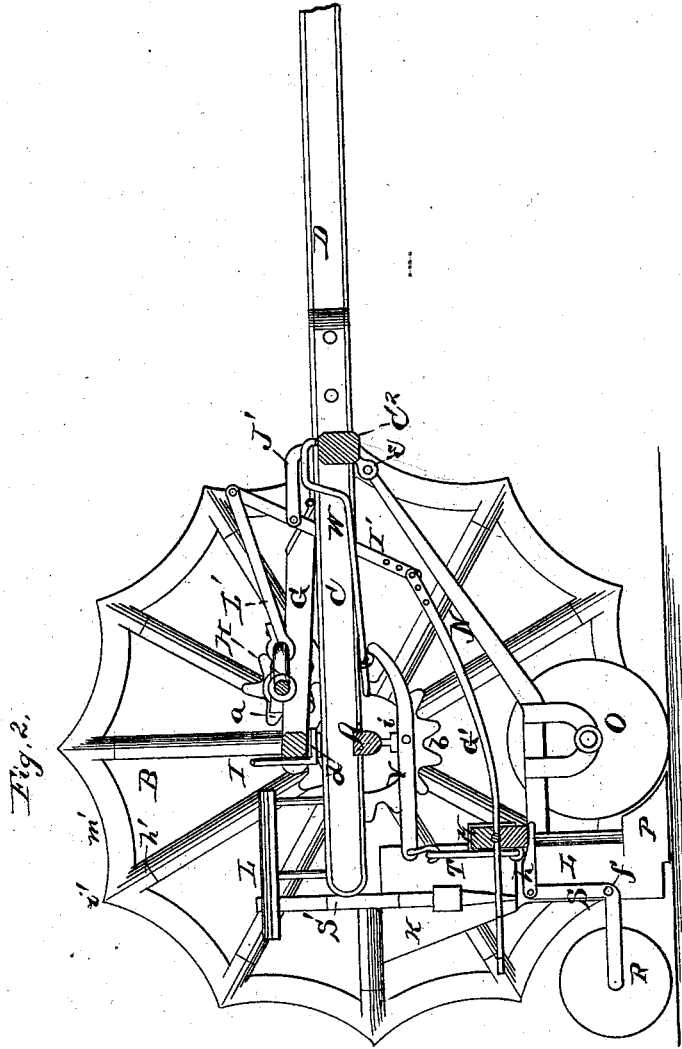

Witnesses:
H. C. McArthur,
C. S. Evert.

Inventor:
Samuel B. Davis
Per: J. H. Alexander & Elliott,
Attorneys.

S. B. DAVIS.
Seed-Planter.

No. 203,122.

Patented April 30, 1878.

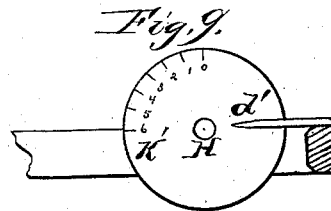
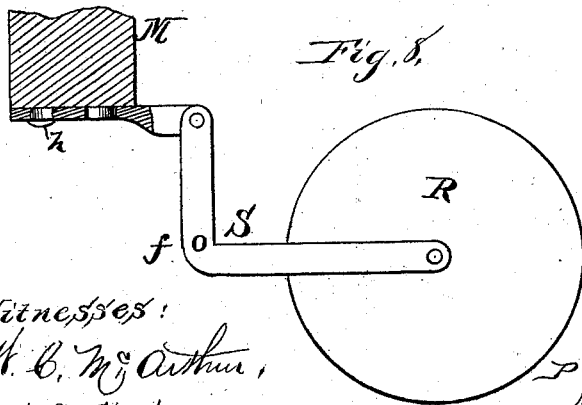
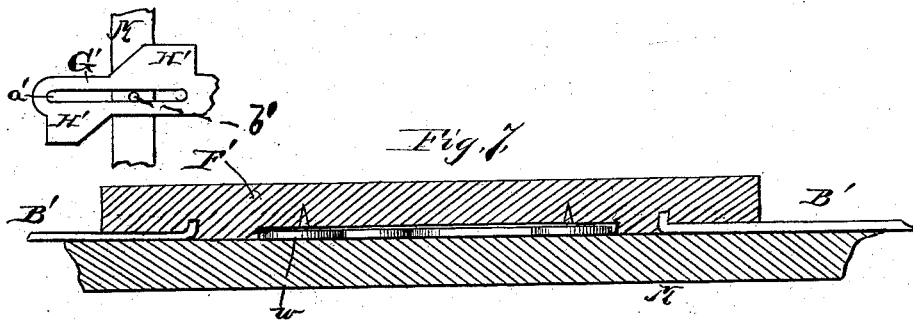
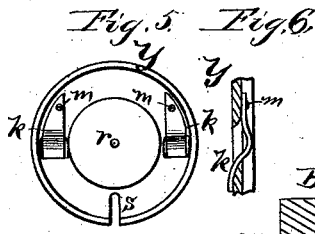
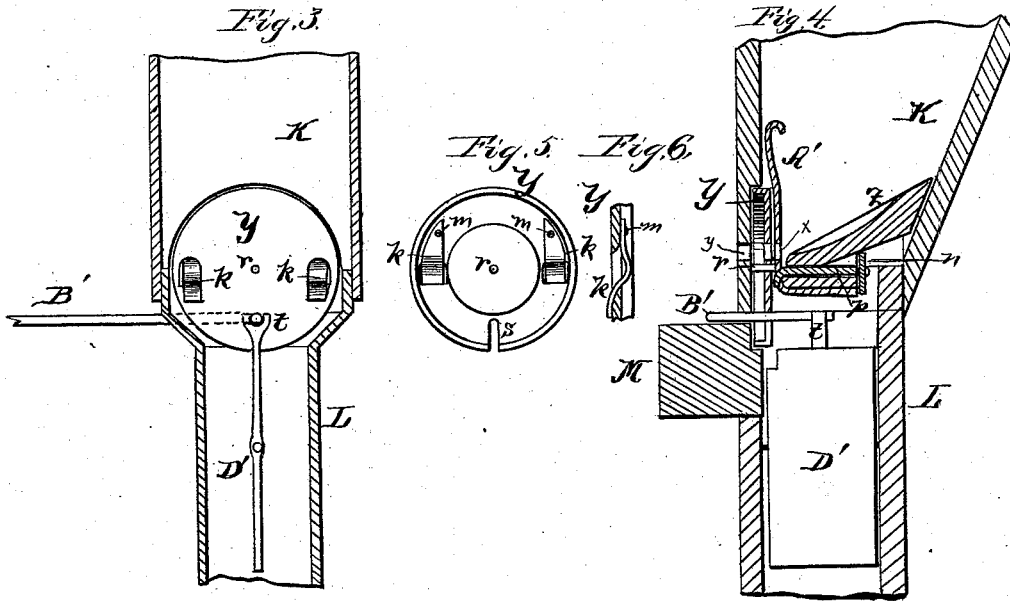

Witnesses:
H. B. McArthur,
A. L. Evert.

Inventor
Samuel B. Davis
 Per
John Alexander Elliott,
 Attorneys.

UNITED STATES PATENT OFFICE.

SAMUEL B. DAVIS, OF HAMBURG, IOWA.

IMPROVEMENT IN SEED-PLANTERS.

Specification forming part of Letters Patent No. 203,122, dated April 30, 1878; application filed January 15, 1878.

To all whom it may concern:

Be it known that I, SAMUEL B. DAVIS, of Hamburg, in the county of Fremont and State of Iowa, have invented certain new and useful Improvements in Seed-Planters; and I do hereby declare that the following is a full, clear, and exact description thereof, reference being had to the accompanying drawings, and to the letters of reference marked thereon, which form part of this specification.

The nature of my invention consists in the construction and arrangement of a seed-planter, as will be hereinafter more fully set forth.

In order to enable others skilled in the art to which my invention appertains to make and use the same, I will now proceed to describe its construction and operation, referring to the annexed drawings, in which—

Figure 1 is a plan view of my improved seed-planter. Fig. 2 is a longitudinal section of the same. Figs. 3 to 9 are detailed views of parts thereof.

A represents the axle, with driving-wheels B B placed upon its ends. To the axle A are secured four parallel beams, C C and C¹ C¹, connected a suitable distance in front of the axle by a beam, C², running parallel with the axle.

The two center beams C C extend a suitable distance in rear of the axle, to support the seat E; and in front said beams extend a sufficient distance forward of the beam C² to have the tongue D secured between them. Upon the frame thus constructed is a frame, G, hinged at its front end, and in suitable bearings upon said hinged frame is placed a crank-shaft, H, having a pinion, *a*, on each end, which pinions gear with similar pinions *b b* secured upon the inner ends of the hubs of the driving-wheels B B. The rear end of the frame G is raised to throw the wheels *a* and *b* out of gear by means of a lever, I, pivoted on the rear of said frame, and working against a plate or bar, *d*, on the main frame. When the said cog-wheels are thrown in gear the frame G is held down upon the main frame by means of hooked levers J J, pivoted to the main frame and made to engage over the shaft H.

K K represent the corn-boxes, provided with downwardly-extending conductors L L,

and secured to and connected by a bar, M, which is secured to two metal frames, N N, one at each end. The front ends of these frames are hinged in eyebolts *e e* on the bar C². Each frame N is constructed to receive a circular rolling colter, O, placed upon a bolt therein, directly in front of a mold or furrow opener, P, which is secured to the front at the lower end of the conductor L.

R represents the covering-wheel in rear of each conductor L. This wheel is mounted on a pin or bolt passing through the rear ends of two L-shaped arms, S S, which are fastened at their angles by a single bolt or pin, *f*, passing through the rear side of the conductor, said arms being placed one on each side thereof. The upper ends of the arms S S have bars *h h* pivoted to them, and the front ends of said bars fastened by bolts to the under side of the bar M.

The bars *h* are perforated, so that their connection with the bar M can be changed, and the arms S thus turn upon the pin *f* as upon a pivot, whereby the covering wheel or roller R can be adjusted up or down to regulate the depth in the ground that the seed is to be put, and then covers the seed. The mold or opener P that follows the rolling colter O divides the ground so that the corn drops into the ground through the spout or conductor L, and then the wheel R covers it.

It will be noticed that the rolling colters, corn-boxes, molds, spouts, and rollers are all connected together.

To the bar M is attached a bail, T, which is connected to the rear end of a lever, V, pivoted in a forked stud, *i*, under the axle A. The front end of the lever V is operated upon by a crank-lever, W, whereby the planting mechanism—*i. e.*, hoppers, colters, covering-wheels, &c.—may be raised and lowered as required.

In the front of each box K, on the inner side, is a recess to receive the circular dropping-plate Y, in which are two holes, and in each hole is inserted a bent metal plate or strip, *k*, to form the dropping-pocket. The outer side of the plate Y—that is, the side toward the front of the machine—is recessed, as shown in Figs. 4 and 5, and the upper ends of the strips *k* are fastened in said recess to

the plate by set-screws *m*. They are then bent, as shown in Fig. 6, and pass through toward the inner side of the plate Y, to form the dropping-pockets. The bottom Z of the box is inclined from front to rear, and formed with a central ridge, to form, as it were, two grooves for conducting the corn to the dropping-plate. The dropping-plate Y is covered by a plate, A', inside the box, which plate A' is attached to the bottom Z, and provided with two holes, *x x*, through which the corn passes to the pockets. Below these holes are cut-off slides *p p*, which are flanged at their front ends. These cut-offs pass horizontally through under the inclined bottom Z, and their rear ends are V-shaped and acted upon by a spring, *n*, which forces them forward.

The dropping-plates Y are rocked upon central pivots *r* by devices hereinafter described, and as each pocket, in succession, passes below the bottom Z, the corn drops into the spout or conductor L, the cut-offs *p p*, actuated by the spring *n*, preventing any grains of corn from getting in between the operating parts.

The strips *k*, which form the dropping-pockets, can be adjusted through openings *y y* in the front of the box by means of the set-screws *m m*, so as to drop more or less at each time, as may be desired.

In the lower part of each dropping-plate Y is a radial slot, *s*, through which passes one arm of an L-shaped rod, B'. This arm also enters a fork, *t*, attached to the upper end of a valve, D', pivoted in the spout or conductor L, whereby the corn is arrested in said spout, and afterward dropped directly into the furrow in the usual manner.

The inner arms of the L-shaped bars B' B' lie on the bar M, and are fastened in grooves on the under side of a bar, F', which slides back and forth in keepers *v v* on top of said bar M. The under side of the bar F' is cut out in the center, and at each end of said cut-out or recess is pivoted a friction-roller, *w*. G' represents a connecting-bar, of substantially the form shown in Fig. 2. The rear end of this bar is flattened, and has on each side an inclined wing, H', and in the center a longitudinal slot, *a'*. This portion of the bar G' passes between the rollers *w w* in the recess of the bar F', and a pin, *b'*, projects from the bar M into the slot *a'*, to guide the movement of said bar G'.

It will readily be seen that if the bar G' be moved backward and forward the wings H' H', acting alternately upon the rollers *w w*, will move the slide F' with the rods B' B' alternately from side to side, and thereby operate the dropping-plates Y and valves D'.

The front end of the bar G' is adjustably connected to the lower end of a lever, I', which is pivoted in the end of an arm, J', secured on the front of the main frame, and the

upper end of said lever I' is, by a pitman, L', connected with the crank in the center of the crank-shaft H, whereby thus the dropping mechanism obtains its required motion. On the crank-shaft H is secured an index-wheel, K', numbered so as to show where the drop is made. An index, *d'*, is secured to the frame G, to point on said wheel D', number 0 being the point at which the drop is made. The numbers on this wheel indicate the distance in inches from the bar connecting the boxes to the point at which the stakes should be set. The stakes are to be set up at the point indicated to show where to start in on the next two rows. The stakes are marked off in inches to show the proper distance at which they are to be set from said bar. S' S' are the graduated stakes, which are carried on the machine by being inserted in suitable keepers on the sides of the hoppers. The driving-wheels B B are constructed of the usual hubs and spokes. The rim of each wheel is made in one piece with sockets *h'* for the tenons of the spokes, points *i'* opposite said tenons, and concave edges *m'* between the points.

Having thus fully described my invention, what I claim as new, and desire to secure by Letters Patent, is—

1. The combination of the hopper or box K, having apertures *y* in its front side, the reciprocating rotating dropping-plate Y, perforated as described, and the strips *k k*, adjustably arranged on the plate Y, and in the perforations thereof, by means of the screws *m*, which are opposite the apertures *y* in the box K, whereby the strips *k* may be adjusted from the outside of the box, substantially as herein set forth.

2. The combination of the box K, rotary reciprocating dropping-plate Y, the stationary vertical plate A', inclined bottom Z, and flanged cut-offs *p p*, actuated by the spring *n*, all substantially as and for the purposes herein set forth.

3. The combination, in a planter, of the bar G', operated from the crank-shaft H by the pitman L' and lever I', and provided with the longitudinal slot *a'* and inclined side wings H' H', the bar M, having pin *b'* passing through the slot *a'* in said bar G', the recessed slide F', having friction-rollers *w w*, the L-shaped rods B', dropping-plates Y with slots *s*, and the valves D' with forks *t*, all constructed and arranged substantially as and for the purposes herein set forth.

4. The driving-wheel B, having its rim made of one piece, with spoke-tenon sockets *h'*, points *i'*, and concave edges *m'*, as set forth.

In testimony that I claim the foregoing as my own I affix my signature in presence of two witnesses.

SAMUEL B. DAVIS.

Witnesses:

W. S. WYNN,
C. H. WYNN.