

# I. GRÖBLI, H. RIETER, Jr., & J. WEHRLI. Embroidering-Machine.

No. 203,143.

Patented April 30, 1878.

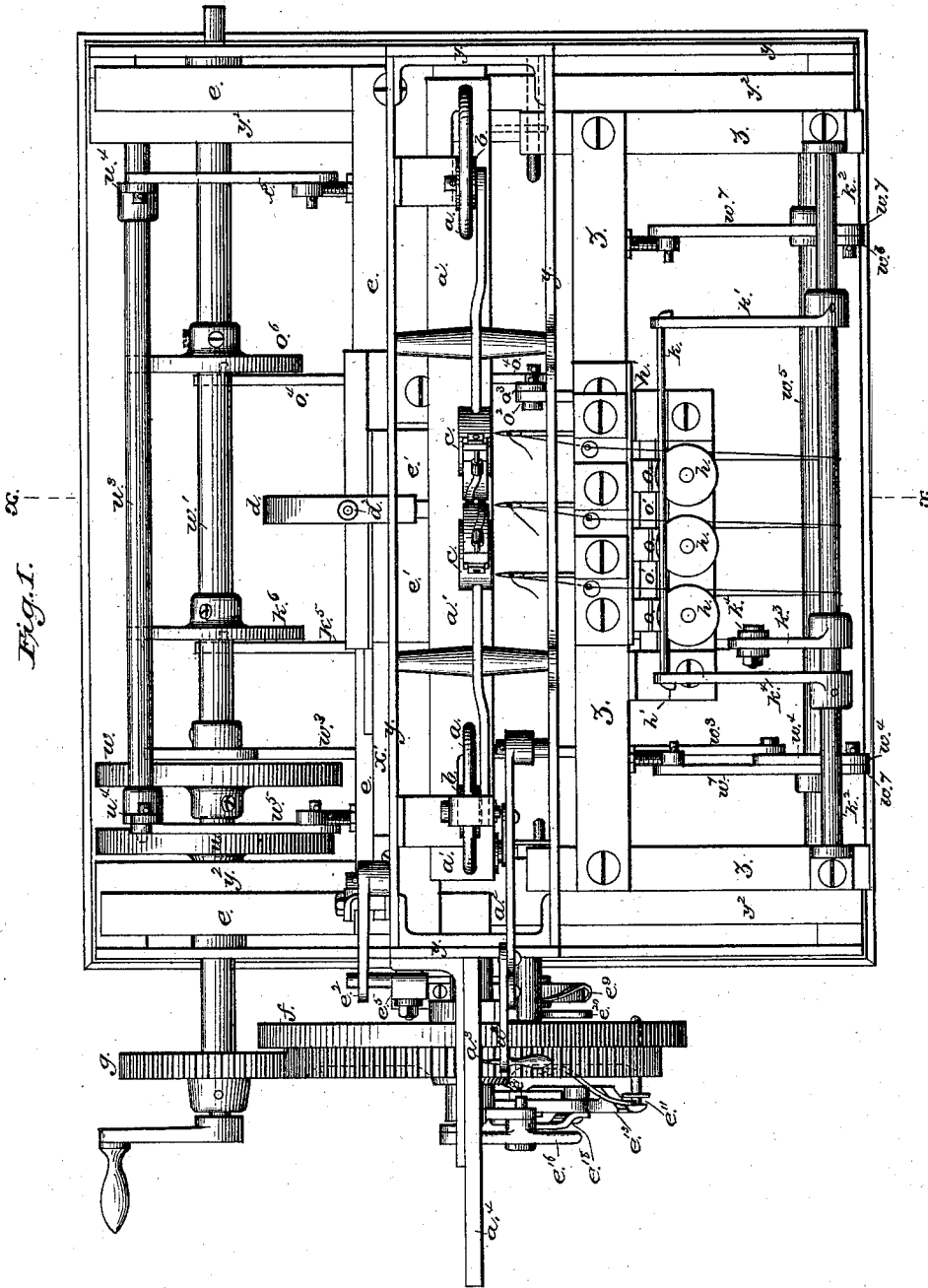

Attest:  
*W. L. Remond.*  
*E. S. Nightman.*

Inventors:  
*Isaac Gröbli - Henry Rieter jun. John Wehrli*  
*per Chas. B. Drummick atty*

I. GRÖBLI, H. RIETER, Jr., & J. WEHRLI.  
Embroidering-Machine.

No. 203,143.

Patented April 30, 1878.

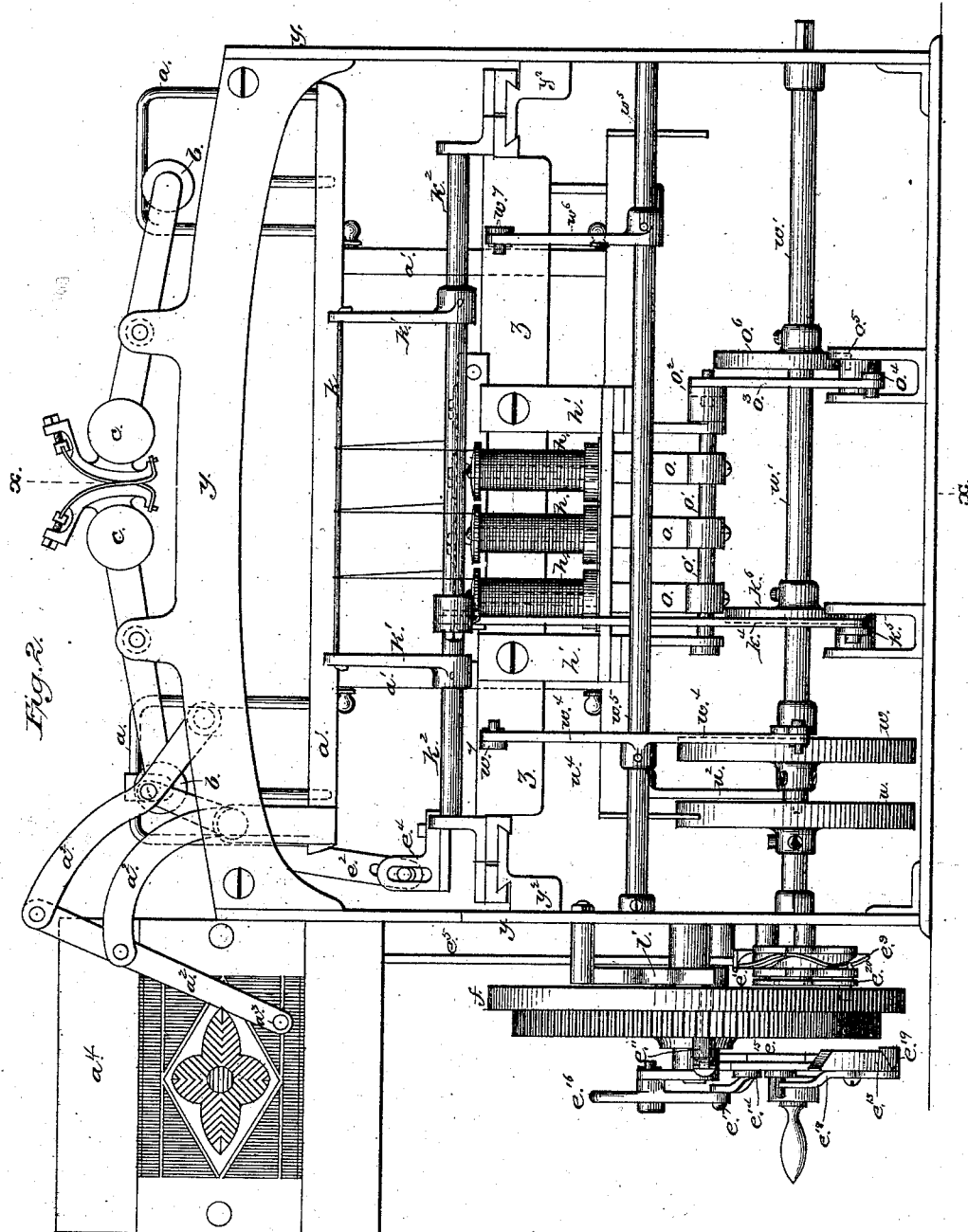

Attest:  
*W. L. Bennett.*  
*Jas. S. Wightman.*

Inventors:  
*Isaac Gröbli-Henry Rieter jun John Wehrli*  
*per Henry Berwick atty*

I. GRÖBLI, H. RIETER, Jr., & J. WEHRLI.  
Embroidering-Machine.

No. 203,143.

Patented April 30, 1878.

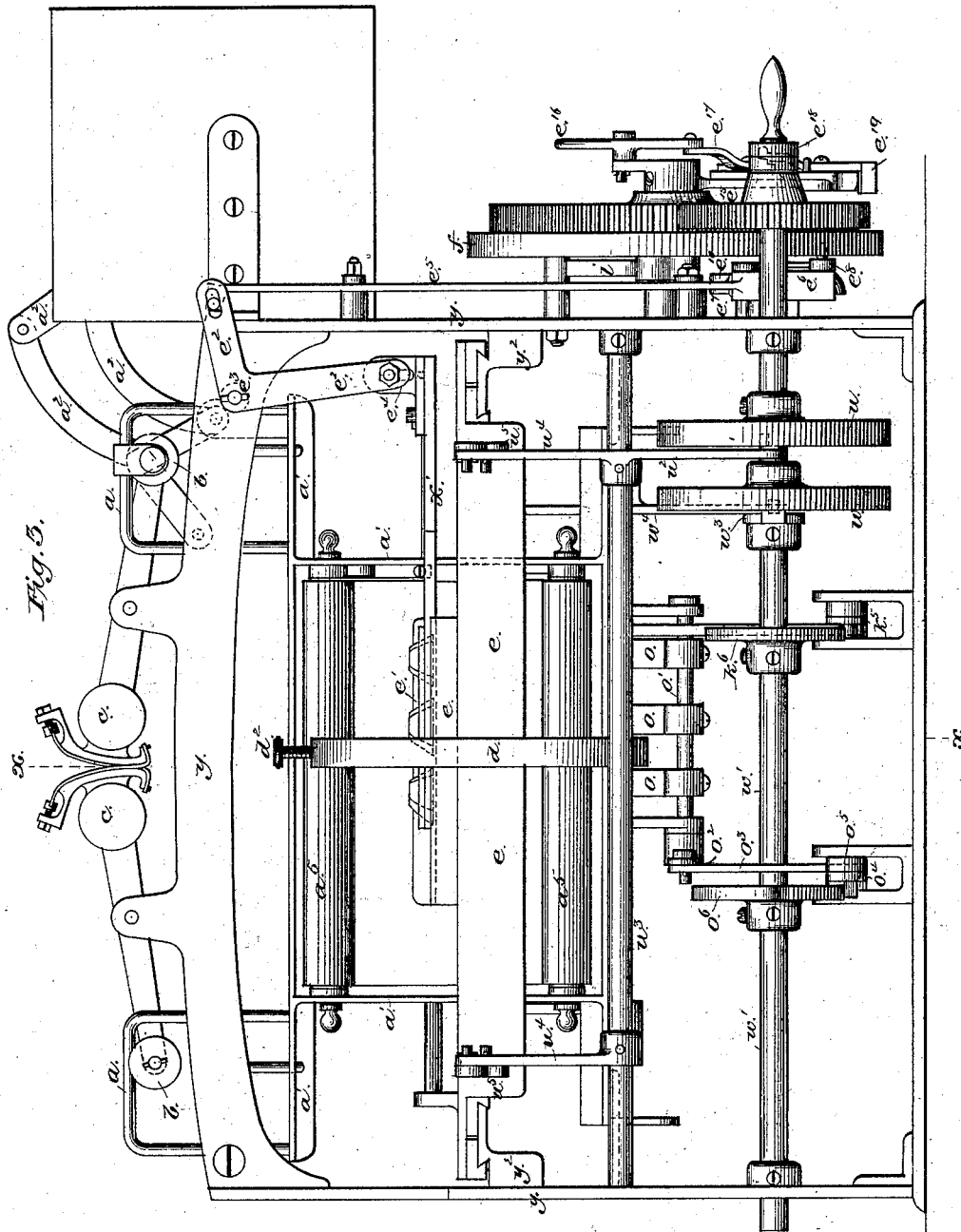

Attest:  
*W. L. Bennett.*  
*J. S. Wightman.*

Inventors:  
*Isaac Gröbli—Henry Rieter jun.—John Wehrli*  
*per Henry B. Connick atty*

I. GRÖBLI, H. RIETER, Jr., & J. WEHRLI.  
Embroidering-Machine.

No. 203,143.

Patented April 30, 1878.

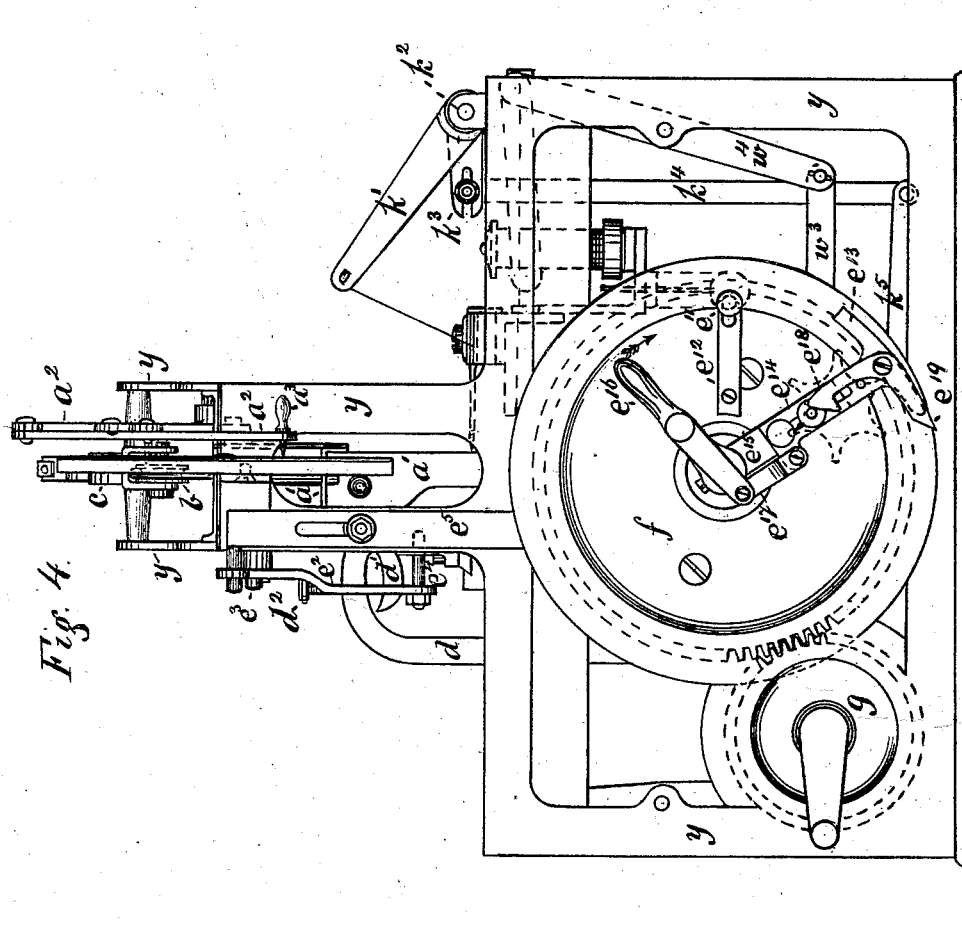

Fig. 4.

Witnesses.  
*W. L. Garrison*  
*Edw. S. Wightman.*

Inventors.  
*Isaac Gröbli-Henry Rieter jun. John Wehrli*  
*per Henry Starnack atty*

I. GRÖBLI, H. RIETER, Jr., & J. WEHRLI.  
Embroidering-Machine.

No. 203,143.

Patented April 30, 1878.

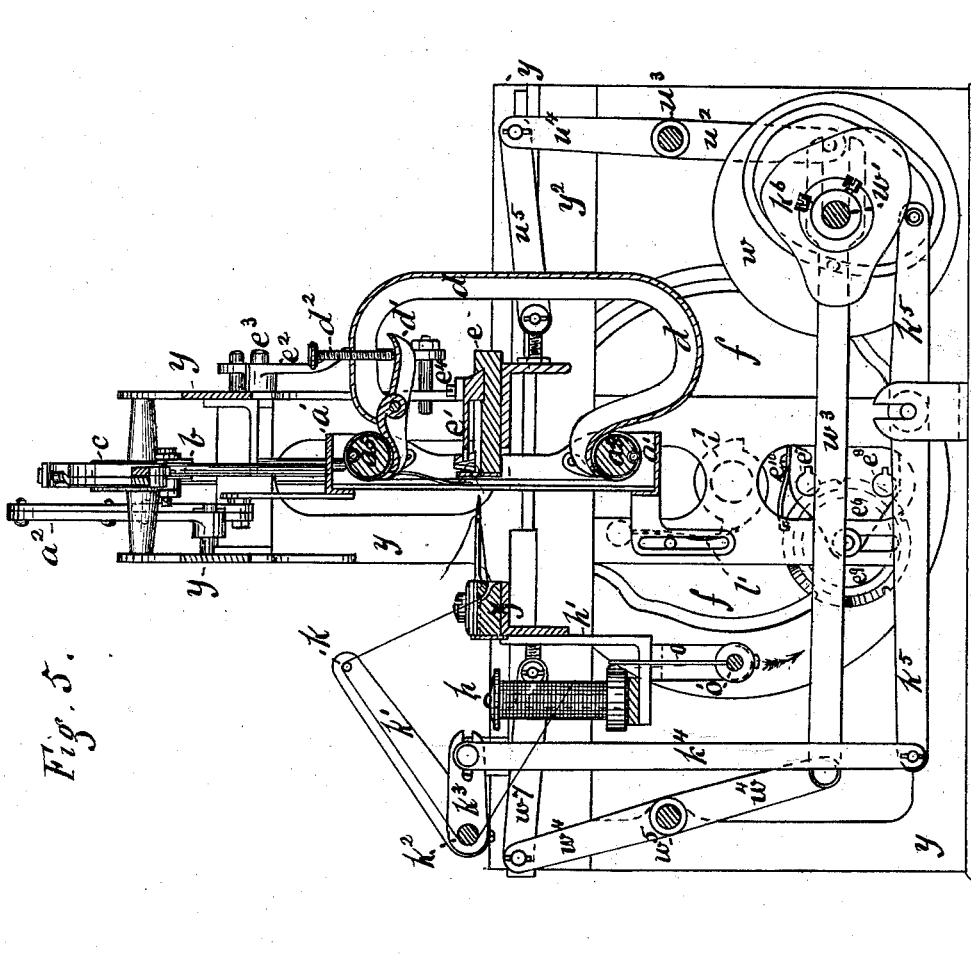

Fig. 5.

Witnesses.

*W. L. Bennett.*  
*Chas. S. Wightman.*

Inventors.

*Isaac Gröbli—Henry Rieter jun.—John Wehrli.*  
*per Henry B. Wainwright atty*

I. GRÖBLI, H. RIETER, Jr., & J. WEHRLI.  
Embroidering-Machine.

No. 203,143.

Patented April 30, 1878.

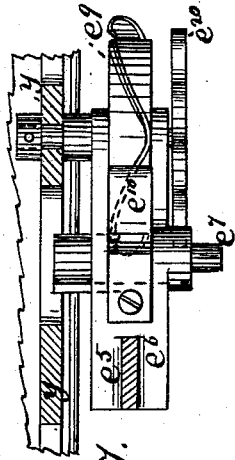

Fig. 7.

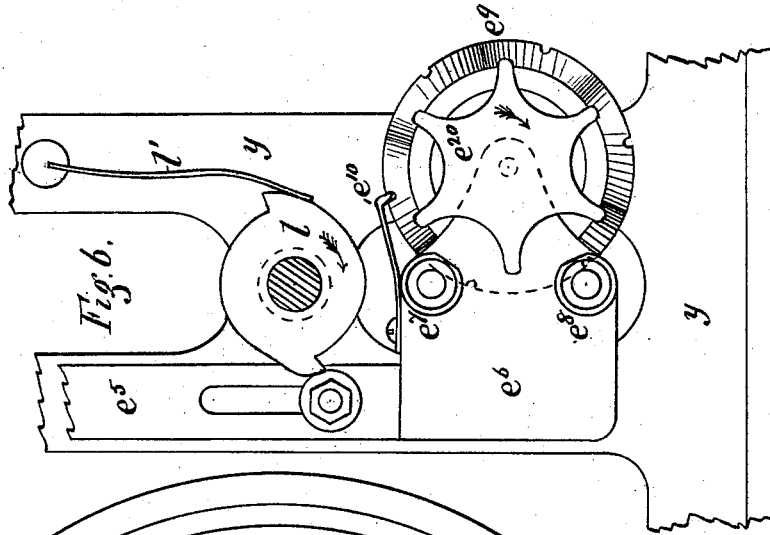

Fig. 6.

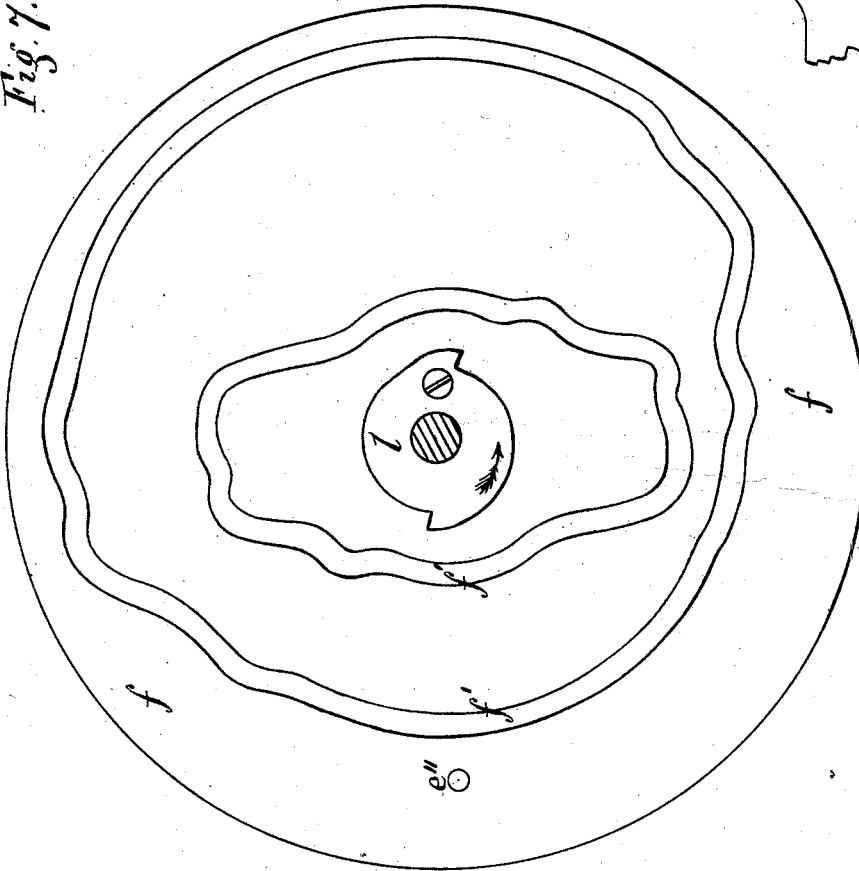

Fig. 8.

Witnesses.

*H. L. Kemmer.*  
*Ed. S. Wrightman.*

Inventors.

*Isaac Gröbli—Henry Rieter jun.—John Wehrli*  
*per Henry Rieter jun.*

I. GRÖBLI, H. RIETER, Jr., & J. WEHRLI.  
Embroidering-Machine.

No. 203,143.

Patented April 30, 1878.

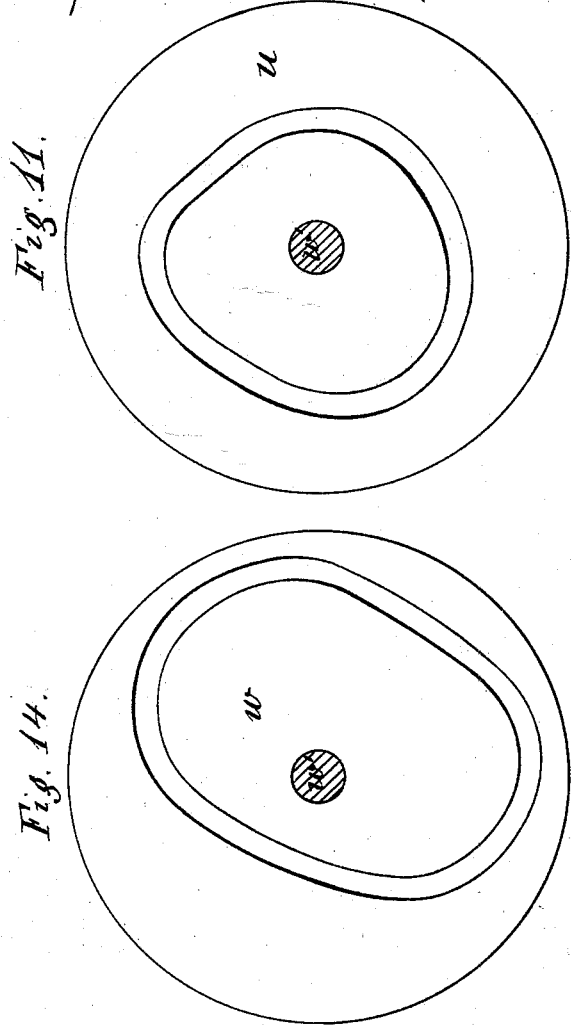
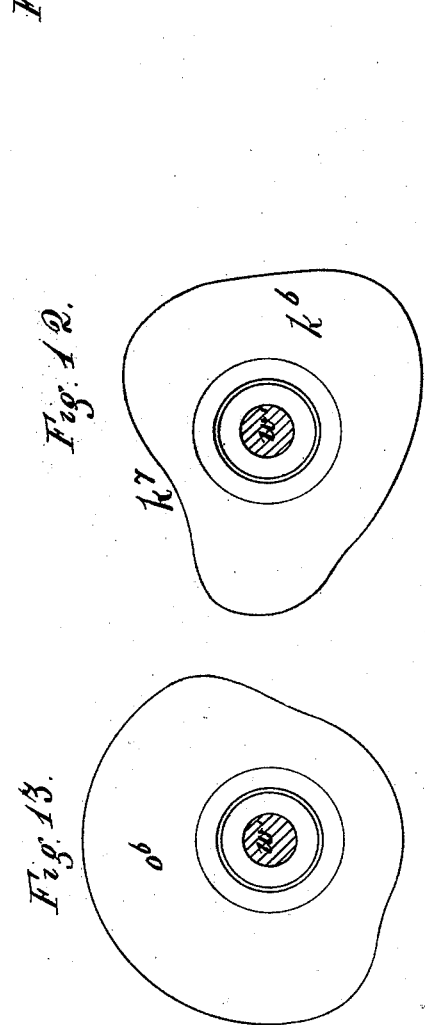
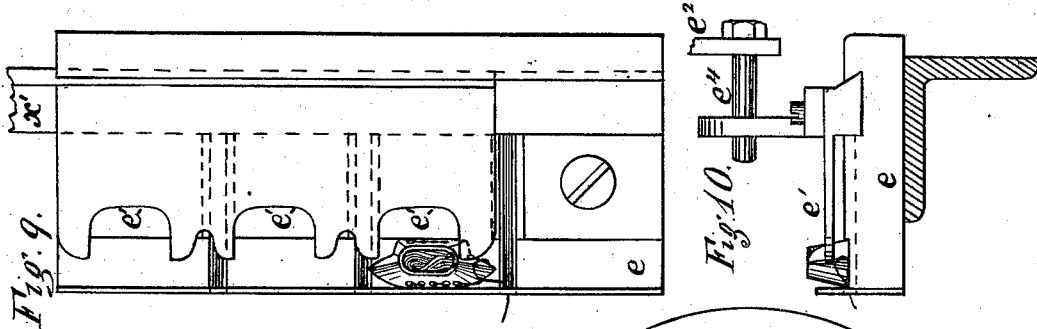

Witnesses.  
*W. L. Bennett.*  
*J. S. Wightman.*

Inventors.  
*Isaac Gröbli-Henry Rieter jun-John Wehrli*  
*per Henry Rieter jun*

# UNITED STATES PATENT OFFICE.

ISAAC GRÖBLI, OF WÜLFINGEN, HENRY RIETER, JR., OF WINTERTHUR,  
AND JOHN WEHRLI, OF WÜLFINGEN, SWITZERLAND, ASSIGNORS TO  
F. A. KURSHEEDT AND A. E. KURSHEEDT, OF NEW YORK, N. Y.

## IMPROVEMENT IN EMBROIDERING-MACHINES.

Specification forming part of Letters Patent No. **203,143**, dated April 30, 1878; application filed  
October 26, 1877; patented in England, December 30, 1873.

*To all whom it may concern:*

Be it known that we, ISAAC GRÖBLI, of Wülflingen, HENRY RIETER, Jr., of Winterthur, and JOHN WEHRLI, of Wülflingen, in the Republic of Switzerland, have invented certain new and useful Improvements in Embroidering-Machines; and the following, taken in connection with the drawings, is a full, clear, and exact description thereof.

These improvements are represented in the drawings as applied to a machine in which the embroidery is produced by means of a gang of needles and a gang of shuttles, each needle and shuttle acting to make embroidery-stitches by interlocking threads much in the same way that a needle and shuttle act in an ordinary sewing-machine; and the improvement, which relates to the mechanism, by means of which a differential drag is imposed upon the bobbins, is applicable only to embroidery-machines using needles and shuttles.

The other improvements are applicable to any kind of embroidering-machine in which a frame whose motions are governed by a pantograph is employed—such as tambour-stitch machines, and those which use a needle with a point at each end and an eye in the middle.

In the drawings, Figure 1, Sheet 1, is a top view or plan of the machine. Fig. 2, Sheet 2, is a side elevation thereof from the side on which the attendant stands. Fig. 3, Sheet 3, is also a side elevation, but taken on the opposite side of the machine. Fig. 4, Sheet 4, is an end elevation thereof. Fig. 5, Sheet 5, is a vertical transverse section through the machine on the line *xx* of Fig. 1. Sheets 6 and 7 contain figures of details.

These drawings show mechanism for transferring the rollers which impart motion to the shuttles from one groove of a cam to another, which are of our invention, and which are specially described and claimed in another application for a patent now pending.

Letters Patent for the inventions herein described and claimed were granted in England to H. B. Barlow as a communication from us, December 30, 1873, No. 4,278.

Prior to the date of our invention it was common to use in embroidering-machines a

frame provided with rollers, between which latter the cloth was kept stretched, said frame being supported by means of staples, as shown at *a a* in Figs. 1, 2, and 3, upon friction-sheaves, as shown at *b b*, which sheaves were supported by bent counterpoised levers, fulcrumed near their center, the frame being counterbalanced by weights, as at *c c*, and the end of these levers which adjoined each other were usually provided with cog-segments which geared into each other, so that the levers were caused to move as nearly simultaneously and regularly as was possible. Under this construction there was a difficulty in causing them to move exactly at the same time and through the same spaces, owing to the fact that cog-teeth are never exact fits, each of the other, and consequently there was a backlash when the movement of the frame was changed from upward to downward, and vice versa.

Further, in such constructions prior to our inventions, these counterpoise-levers were, so far as we know, bent levers, and they consequently worked on the principle of the old Roman balance, and the counter-balances and the weight of the frame counterbalanced each other exactly only in certain positions of the levers. In order to remedy the first of these difficulties, we have dispensed with the cog-gearing on the adjoining ends of the levers, and have provided these ends each with a smooth segment of a cylinder, and have attached to the lower end of each of these segments, and to the upper end of each adjoining segment, as clearly shown in the drawings, a thin ribbon of steel or other metal, made in cross-section like an ordinary clock-spring, (the segment should be about twice as wide as the ribbons;) and we prefer to fasten the ribbons at one end by means of a screw and nut, as shown in the drawings, so that the ribbon may be strained tight. Under this construction there can be no backlash, and each lever must rise and fall exactly through the same distance and at the same time the other does.

Instead of using bent levers to support the frame, as has heretofore been the case, we make these levers straight, or, in other words, so form the levers and locate the friction.



sheave and the counterbalance-weight that the center of the sheave, the fulcrum of the lever, and the center of gravity of the counterbalance-weight are all in the same straight line. In order to use such levers, and at the same time keep the cloth-rollers as near together as possible, we have elongated the staples *a a*, thereby bringing the frame into the same vertical relation to the fulcrum of the levers as it would occupy if the sheave end of the levers had been bent downward and the frame supported upon them by short staples, as in the old construction.

This new form of lever, with the counterbalance and sheave located thereon, as described, will balance the frame equally well whether fully up or fully down, or in intermediate positions, because the center of the sheaves and the center of the counterbalance-weights are always at the same angular distance, the one above and the other below a horizontal line.

In embroidering-machines it is, as before stated, usual to stretch the cloth between two rollers with horizontal axes, the one located near the top and the other near the bottom of a quadrangular frame. These rollers are usually provided with pawls and ratchets, so as to hold them in fixed angular positions when necessary, and the cloth is unrolled from one roller and rolled onto the other roller as the exigencies of the work require.

In order to make good embroidery, it is necessary that the fabric to be embroidered should be kept tightly and evenly stretched. It is difficult to do this in the machines used prior to our invention, as the rollers are long, (sometimes fifteen feet in length,) and are apt to sag unless made so heavy as to introduce other difficulties into the operation of the machine. We have remedied this difficulty by the use of an adjustable and removable stay, which can be applied to the rollers and set up between them in such manner as to force the rollers apart at those points where the ends of the stays rest against them. These stays may be constructed in various forms, the essentials being that they should have at each end a concavity to bear upon the cloth which is wound upon each roller, or upon the rollers themselves, and some means of forcing these two concave ends apart, so as to press one roller away from the other. We prefer to make these adjustable stays of a form best shown in Fig. 5, Sheet 5, and Fig. 3, Sheet 3, of the drawings. It is there represented, at *d d*, as made of a piece of metal whose cross-section is in the form of a trough, so as to secure both strength and lightness. This piece of metal is bent, as shown in Fig. 5, so as to form a concavity at the lower end which will bear upon the upper side of the lower cloth-roller. It is then bent downward and away from the cloth, and then upward, and again toward the cloth. These bends, as will appear by reference to Fig. 5, are made for the purpose of permitting the shuttle-carriage

(shown at *e*, Figs. 3 and 5) to move outward and inward, as required, and for the further purpose of permitting the cloth-rollers and their frame to move up and down as far as necessary without any danger of the adjustable stay striking the shuttle-carriage. To the upper end of this bent piece of metal is pivoted a lever, *d'*, of the same trough-shaped cross-section, which lever is formed into a concavity on its upper side on that end nearest the cloth. This concavity bears against the under side of the upper cloth-roller. The outer end of this lever lies under a set-screw, *d<sup>2</sup>*. An inspection of the drawings will show that the turning of this screw in the proper direction will force the two concavities apart, and thus tend to force the two rollers apart and stretch the cloth which is supported between them. By turning this set-screw in the opposite direction the concavities may be caused to approach each other, so that the cloth-rollers may be turned, or so that the adjustable stays may be removed.

In an actual machine as many of these adjustable stays may be used as the necessities of the case may require, and it is obvious that the concavities may be caused to approach and recede from each other by the use of various devices known to mechanics, and that the contrivance may be formed of metal of any proper cross-section, either solid or tubular.

In a former machine, for which application for Letters Patent is made by us simultaneously herewith, the thread-bobbins shown at *h h h*, Figs. 1, 2, and 5 in the drawings, are described as having a constant drag put upon them, or the thread leading from them, in any way usual in sewing-machines or embroidering-machines. Since the date of that invention we have discovered that the machine would do better work with an intermittent drag or friction upon these spools or bobbins, so that they at times would revolve under slight friction only, and at other times would be retarded by a spring or other brake bearing upon them. Under this construction there is less danger of breaking or stretching the threads in the act of unwinding them from the bobbins, and the stitches can be drawn tighter.

In the drawings a spring-brake, *o*, is shown as located near each bobbin, these springs being supported in hubs secured upon a rock-shaft, *o<sup>1</sup>*, to one end of which is applied a rocking arm, *o<sup>2</sup>*. This arm is, by means of a link, *o<sup>3</sup>*, connected to a lever, *o<sup>4</sup>*, pivoted at *o<sup>5</sup>*, and provided with a roller at the end farthest from the link. This roller underlies a cam, *o<sup>6</sup>*, secured upon the shaft *w'*, the whole construction being such that the revolution of the cam at times causes the brakes to bear upon the rims of the bobbins and at times to relax their pressure wholly or in part, as may be desired. The relaxing of the pressure is caused by the weight of the link *o<sup>3</sup>* and the rocking arm *o<sup>2</sup>*, tending always to pull the brakes away from the bobbins; but this relaxing motion may be made positive by employing a grooved track-

cam, in which track the roller will rest. The bobbins are set upon a piece of plush or cloth, or have a light spring applied to their rims, which acts constantly. When the needles are home in the cloth the cam *c*<sup>6</sup> causes the brakes governed by it to bear upon the bobbins, and this pressure is continued until the needles are retracted to their full or nearly full extent, and then relaxed, the brakes moving away from the bobbins.

It will thus appear that the threads can only be unwound by a strong pull, if at all, while the stitch is being pulled tight, and that the thread will unwind easily while the cloth-frame is being moved in the intervals between the stitching, such motion unwinding the thread necessary for a new stitch from the bobbins.

Stiff levers armed with shoes of india-rubber or leather or cloth may be used in place of the spring-brakes.

The drawings show the ordinary pantograph connected with the cloth-frame, also all the mechanism necessary for giving motion to the shuttles and shuttle-carriage, and likewise to the needles and take-up apparatus when motion is imparted to the wheels *f* or *g* in any proper manner. We do not describe these parts of the drawings, as they form no part of the invention claimed in this patent.

We do not claim simply a brake acting intermittently on a bobbin, but only claim the same in combination with other elements, as hereinafter specified.

We claim as of our invention—

1. In combination with a cloth-supporting frame and two levers, (by means of weights

on which the cloth-frame is counterbalanced,) two ribbons of metal applied to the adjacent ends of these levers, substantially in the manner described, whereby the two levers are forced always to move through the same distances at the same time, and to sustain the same relation each to the other, the combination being substantially such as described.

2. In combination with a cloth-frame and staples, counterpoise-levers shaped as described, whereby the center of the sheave which supports the frame, the fulcrum of the lever, and the center of gravity of the counterbalance-weight shall all lie in the same straight line, the combination being substantially such as described, and operating so that the frame is counterbalanced to the same extent in every position which it is capable of assuming.

3. The adjustable and removable stay, constructed substantially as specified, in combination with upper and lower rollers, between which fabric to be embroidered is stretched, the combination being and acting substantially as described.

4. In combination with a cloth-frame, a series of bobbins, and a series of needles, a series of brakes, actuated substantially as described, so as at times to press upon the bobbins and at times to relax their pressure thereon, the combination being and acting substantially as hereinbefore described.

ISAAC GRÖBLI.  
HENRY RIETTER, JR.  
J. WEHRLI.

Witnesses:

S. H. M. BYER,  
C. A. CAFLISCH.