

G. & P. REESE.
Plow.

No. 203,192.

Patented April 30, 1878.

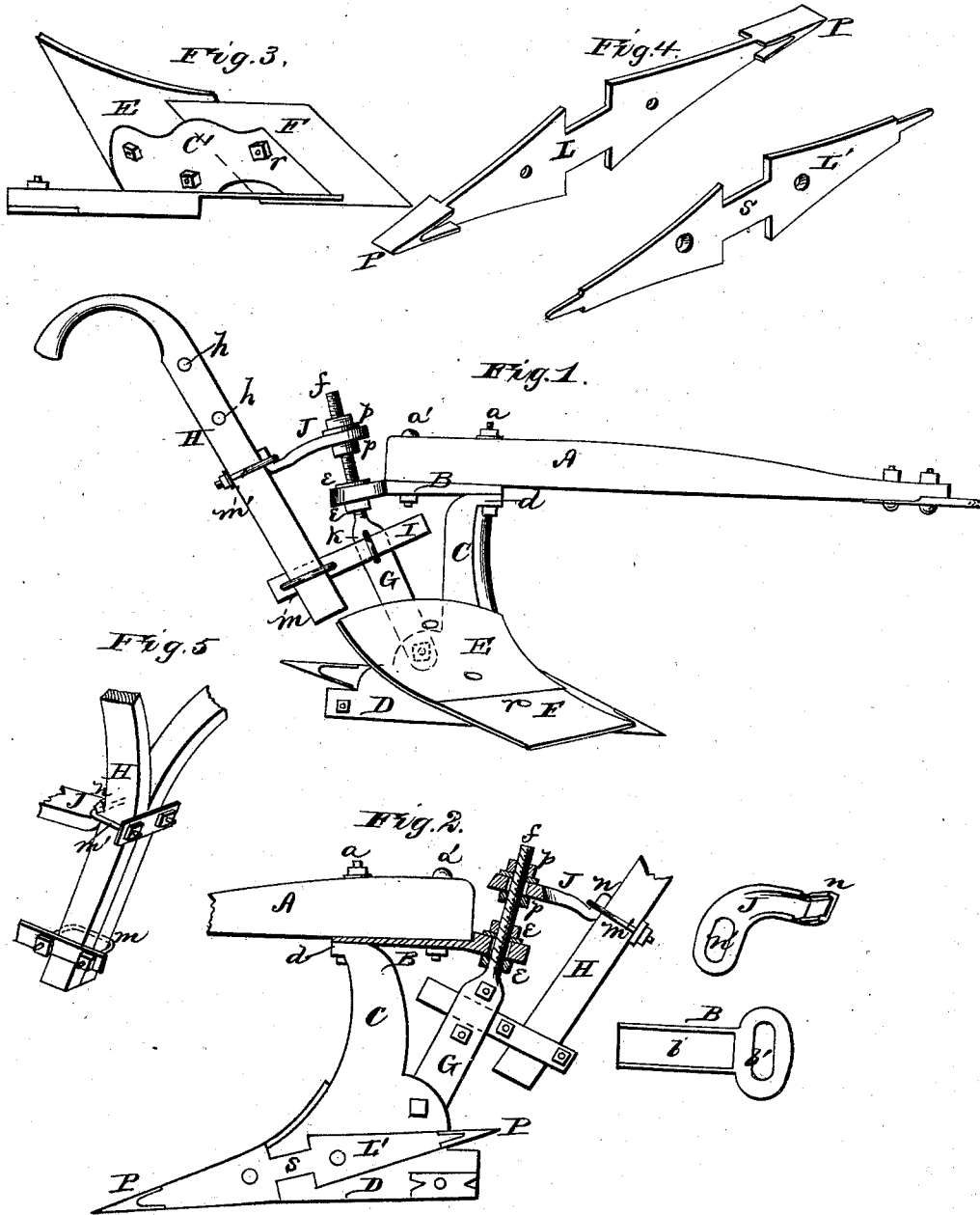

WITNESSES
Chauncy L. Curran
Frank Hall

INVENTOR
Geo Reese and
Paul Reese
Chauncy Curran
ATTORNEYS

UNITED STATES PATENT OFFICE.

GEORGE REESE AND PAUL REESE, OF NEW ALBANY, INDIANA.

IMPROVEMENT IN PLOWS.

Specification forming part of Letters Patent No. 203,192, dated April 30, 1878; application filed March 12, 1878.

To all whom it may concern:

Be it known that we, GEORGE REESE and PAUL REESE, of New Albany, in the county of Floyd, and in the State of Indiana, have invented certain new and useful Improvements in Plows; and we do hereby declare that the following is a full, clear, and exact description thereof, reference being had to the accompanying drawings, and to the letters of reference marked thereon, making a part of this specification.

The nature of our invention consists in the construction and arrangement of plows, as will be hereinafter more fully set forth.

In order to enable others skilled in the art to which our invention appertains to make and use the same, we will now proceed to describe its construction and operation, referring to the annexed drawing, in which—

Figure 1 is a side elevation of our improved plow from the mold-board side. Fig. 2 is a view of the plow proper from the opposite side. Fig. 3 is a bottom view. Fig. 4 shows the reversible points. Fig. 5 shows lower ends of handles.

A represents the plow-beam, to the under side of which, at the rear end, is secured a plate or casting, B, by means of two bolts, *a a'*. The casting B has on its upper side a longitudinal recess, *b*, in which the rear end of the plow-beam fits, the casting projecting beyond the end of the beam and formed with a transverse slot, *b'*.

C is the plow-standard, which also forms the land-side D, and has a flange, *C'*, on one side, along the front curved edge, to receive the mold-board E and share F.

The upper end of the standard has a forward projection, *d*, through which the front bolt *a* passes, for securing the standard C and casting B to the plow-beam.

To the standard C, at a point back of the upper edge of the mold-board, is bolted an arm, G, the upper end of which forms an elongated bolt, *f*, that passes up through the slot *b'* in the casting B, and nuts *e e*, screwed on said bolt above and below the casting, hold said casting firmly to said arm G. By these means the plow-beam may be turned on the bolt *a* and adjusted so that the plow will take more or less land, as desired.

H H are the handles, connected by rounds *h h*, and having their lower ends brought side by side and fastened together by two clips, *m* and *m'*. The lower clip *m* secures the handles to a bar, I, which is in turn, by a clip, *k*, adjustably secured to the arm G. The upper clip *m'* fastens the handles to the upturned end *n* of an arm, J, which extends forward and is curved, as shown, its front end having a slot, *o*, which is placed over the upper end of the elongated bolt *f*, and adjusted up and down and laterally thereon by means of nuts *p p*. By these means the handles can be raised, lowered, and thrown to either side, or, in other words, regulated and adjusted in every direction in any desired manner.

It is, of course, to be understood that the various clips mentioned are provided with nuts for securing them and the parts connected to them firmly in any required position.

The share F is made in diamond form, and fastened through the center by a single bolt, *r*, to the forward part of the flange *C'*. The upper part of the share, when thus in position, lies under the lower portion of the mold-board, this part being beveled for that purpose, as shown. The share can be reversed four times, so as to present four different cutting-edges for the work.

In connection with this plow we also use a bar, L, which is in the form of two spears, connected at their bases by a tongue, *s*, as shown, and laid in a corresponding recess made in the outer face of the land-side D, this recess being in depth equal to twice the thickness of said bar or plate L. At each end of the bar L is secured a double point, P, which extends equally on both sides of said bar, and is in V form, to extend equally on top and bottom.

It will thus be seen that we have four distinct points that can be brought into use by reversing the bar and turning it over. When the bar L is placed in the recess in the land-side, a similar bar, L', is placed on the outer side thereof, filling up the space to make the outer sides of the points P flush with the outside. The point of the standard and the share F fit on the inner side in the angle of the point.

Having thus fully described our invention, what we claim as new, and desire to secure by Letters Patent, is—

1. In combination with the beam A, standard C, casting B, and arm G, with elongated bolt *f* of the handles H H, clips *k m*, arm I, clip *m'*, arm J, having flange *n* and slot *n'*, and the nuts *p p*, substantially as and for the purposes herein set forth.

2. The reversible double spear-bar L, provided with the points P P, forming recesses at each side, in combination with the reversible filling-bar L', having its ends formed with

tenons to fit in the recesses of the points, as and for the purposes herein set forth.

In testimony that we claim the foregoing we have hereunto set our hands this 22d day of February, A. D. 1878.

GEORGE REESE.
PAUL REESE.

Witnesses:

WILLIAM W. TULEY,
ED. SMITH.