

C. SNYDER.
Pumping Apparatus for Oil-Wells.

No. 203,206.

Patented April 30, 1878.

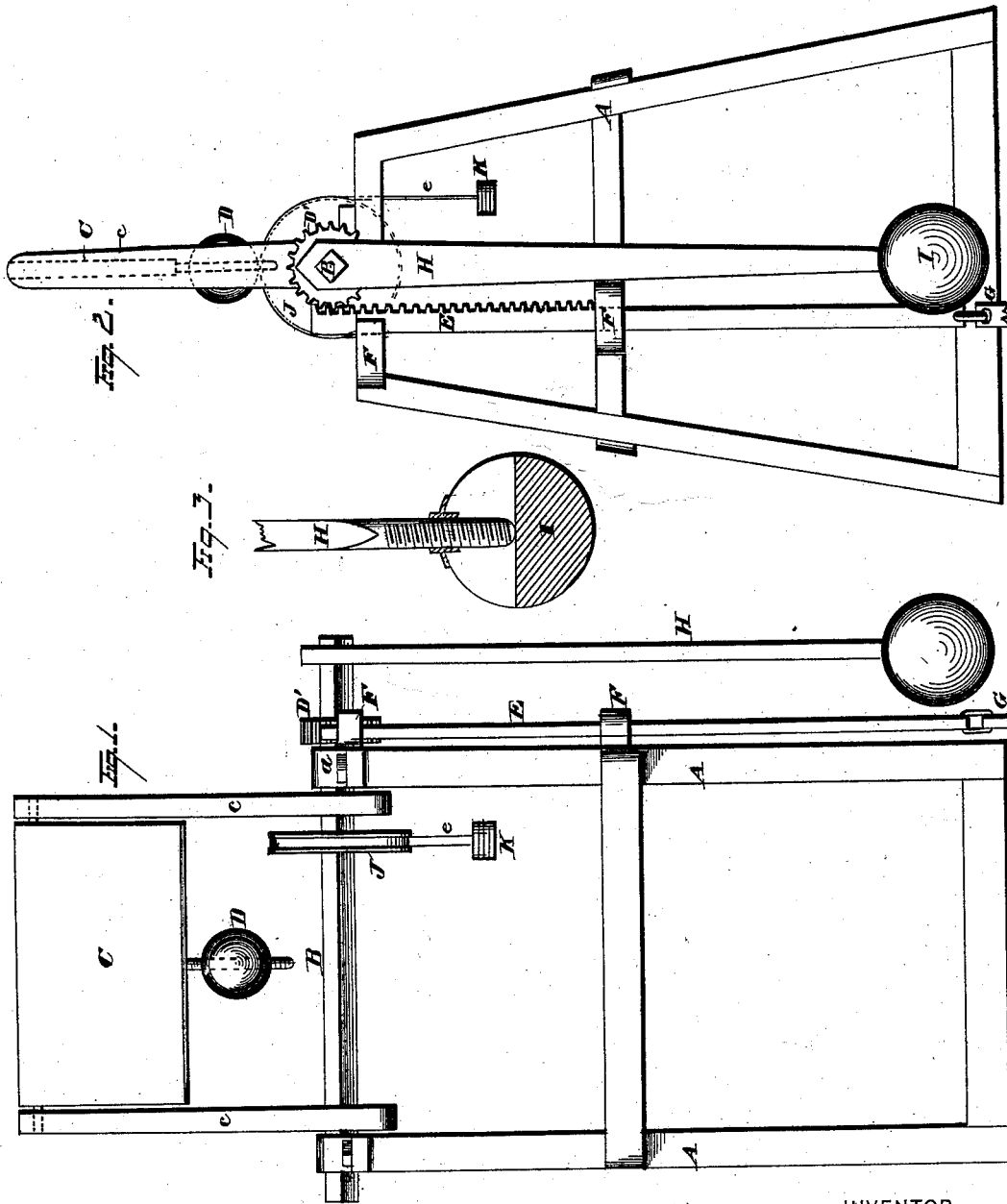

WITNESSES
Edw. J. Northrup
A. W. Bright

INVENTOR
Charles Snyder
By H. A. Seymour
ATTORNEY

C. SNYDER.
Pumping Apparatus for Oil-Wells.

No. 203,206.

Patented April 30, 1878.

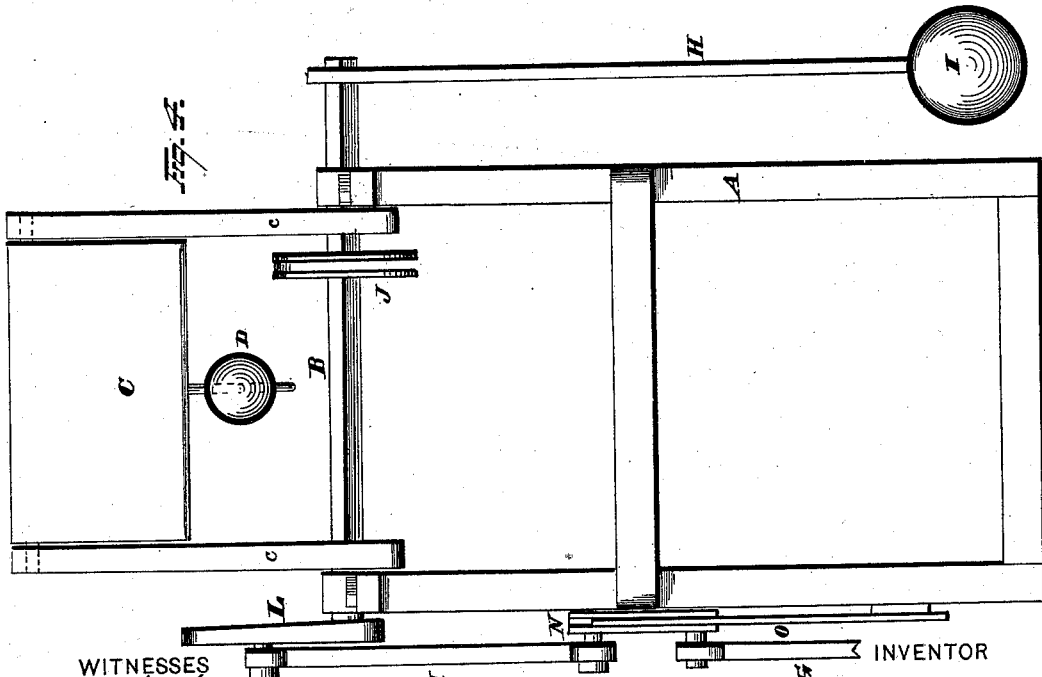
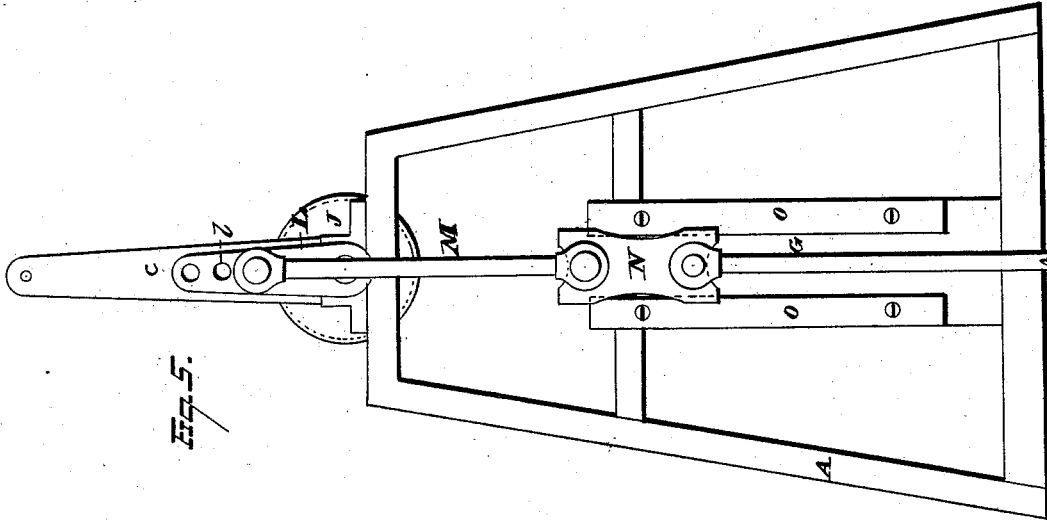

WITNESSES
Edw. S. Nottingham
A. W. Knight.

INVENTOR
Chas Snyder
 By *H. D. Johnson* ATTORNEY

UNITED STATES PATENT OFFICE.

CHARLES SNYDER, OF ROUSEVILLE, PENNSYLVANIA.

IMPROVEMENT IN PUMPING APPARATUS FOR OIL-WELLS.

Specification forming part of Letters Patent No. 203,206, dated April 30, 1878; application filed March 1, 1878.

To all whom it may concern:

Be it known that I, CHARLES SNYDER, of Rouseville, in the county of Venango and State of Pennsylvania, have invented certain new and useful Improvements in Pumping Apparatus for Oil-Wells; and I do hereby declare the following to be a full, clear, and exact description of the invention, such as will enable others skilled in the art to which it pertains to make and use it, reference being had to the accompanying drawings, which form part of this specification.

My invention relates to an improvement in a combined wind and lever power pump for oil-wells.

Heretofore many "head-wells" have not been worked, and a large quantity of oil has been lost, owing to the fact that such wells will not yield a sufficient quantity of oil to warrant the expense necessitated in providing such wells with steam-engines and fuel for operating the pumps. In wells of this class the oil flows into the bore of the well to a certain height, and the quantity of oil accumulating in the well during twenty-four hours can be pumped from the well in from thirty to sixty minutes—or, in other words, in a comparatively short time, which, in some instances, may vary from a fraction of an hour to several hours of a day.

The object of my invention is to provide a simple, cheap, and efficient pumping apparatus, of such construction that the variable force of the prevailing winds shall furnish sufficient power to actuate the pump, and thus dispense with the necessity of providing fuel and costly machinery for such purpose.

My invention consists, essentially, in the combination, with an oscillating fan or wind-board, of a weighted pendulum, the several parts being constructed and arranged as will hereinafter be described, whereby the force of the wind operates to turn the wind-board and raise the sucker-rods attached to the pump; and when the force of the wind is lessened, the weighted pendulum carries the wind board or fan back again to its former position. Thus the variable force of the wind during a given twenty-four hours furnishes sufficient power to impart a sufficient number of strokes to the

pump to raise the oil as it collects in the bore of the well.

In the accompanying drawings, Figure 1 is a side elevation of my improved pumping apparatus. Fig. 2 is an end view of the same. Fig. 3 is a transverse section of one of the weighted balls. Fig. 4 is a side elevation, and Fig. 5 an end, of a modified form of construction.

A are the uprights of a derrick or tall framework; and B is a rock-shaft, journaled in bearings *a* attached to the cap-piece *b* of the frame. To the rock-shaft B are secured the arms *c*, between which is pivoted a wind-board, C, which latter is retained in a vertical position by means of a weighted ball, D, preferably attached to the lower edge of the wind-board in a vertically-adjustable manner, for a purpose hereinafter described.

D is a spur-gear, secured to the rock-shaft B. E is a sliding rack-bar, the teeth *d* of which mesh with the teeth of the gear-wheel D. Sliding rack E is supported in suitable bearings or guides F, attached to the framework of the derrick.

G represents the upper end of the series of sucker-rods, which are attached to the lower end of the rack-bar E, and hence, as the latter is raised and lowered, a corresponding reciprocating movement is imparted to the sucker-rods, which operate the submerged pump in the oil-well. To the outer end of the rock-shaft B is secured a pendulum-lever, H, having a weighted ball, I, attached to its lower end. When the pump is not in operation the weighted ball I will stand in its lowest position, and retain the wind-board in vertical line with the pendulum H.

In order to counterbalance the weight of the sucker-rods, a grooved wheel, J, is attached to the rock-shaft, and a weight, K, is suspended therefrom by a rope or metallic strap, *e*. It will thus be observed that, by swinging the pendulum-lever H to and fro, the sucker-rods are raised and lowered with the expenditure of the minimum amount of power. The weight of the balls may be readily varied, as they are formed hollow and then filled with lead or other material until they are of the desired weight.

The operation of the device, as above described, is as follows: The sucker-rods of the well having been attached to the lower end of the reciprocating rack-bar, the pump is ready for the variable action of the wind. When the wind blows with any considerable force, it operates to force the wind-board to one side or the other of the rock-shaft, thus turning the latter, which also operates to raise the weighted ball on the end of the pendulum-lever. The turning of the rock-shaft serves to raise the rack-bar through the spur-gear, and thus gives an upstroke to the sucker-rods and pump. When the force of the wind is spent or lessened, the weighted ball on the end of the pendulum carries the latter downward, lowering the sucker-rods and again raising the wind-board, to be again acted upon by the wind. In this manner the sucker-rods are raised and lowered, either fast or slow, accordingly as the wind is variable or steady, and the pump is operated without the necessity of an attendant or any expense for fuel, as is the case with pumps now in use.

The pump is not liable to injury from a severe wind-storm, as the wind-board is adapted to be adjusted by the vertically-adjustable weighted ball to withstand any predetermined force; and any excess of such force operates to force the wind-board outwardly in line with the direction of the wind when it only presents its edge to the force of the wind.

There are at present a large number of oil-wells termed "head-wells," which will yield a comparatively small quantity of oil per day, but not a sufficient amount to warrant the outlay necessary to furnish the requisite machinery, fuel, and attendant to operate the pumps now in use; but by means of my improved apparatus these wells can be worked, as the initial cost of the pumping apparatus is all that is required for the successful and continuous working of the wells.

Figs. 4 and 5 represent a modification of my invention. In this form of construction the

end of the rock-shaft is provided with a crank-arm, L, which has one or more holes, l, formed therein for the adjustable attachment of one end of a pitman-rod, M, the lower end of which latter is attached to a slide, N. O are guides, within which the slide N can reciprocate freely. To the lower end of the slide N is attached the upper end of the series of sucker-rods, which extend down into the well. The operation of this modified form of apparatus is the same as that heretofore described.

When the rock-shaft is turned by the force of the wind acting on the hinged wind-board, the crank operates to raise and lower the sucker-rods, and thus actuate the pump.

When there is not sufficient wind to operate the pump, the same may be done by swinging the pendulum, and this may be done by an attendant; or a steam-engine or water-motor may be connected therewith for such purpose. If desirable, a platform may be secured to the pendulum, and the latter operated as a swing.

Having fully described my invention, what I claim as new, and desire to secure by Letters Patent, is—

1. A pumping apparatus for oil-wells, consisting, essentially, in the combination, with a rock-shaft, of a wind-board or equivalent device, to be moved by the force of the wind, and a weighted pendulum-lever, substantially as set forth.

2. In a pumping apparatus for oil-wells, the combination, with a rock-shaft, provided with a weighted wind-board, of a weighted pendulum-lever and a rock-bar, adapted to be reciprocated by a spur-gear secured to said rock-shaft, substantially as set forth.

In testimony that I claim the foregoing I have hereunto set my hand this 28th day of February, 1878.

CHARLES SNYDER.

Witnesses:

HENRY A. SEYMOUR,
THOMAS B. HALL.