

W. TUGGEY.
Stone-Sawing Machine

No. 203,219.

Patented April 30, 1878.

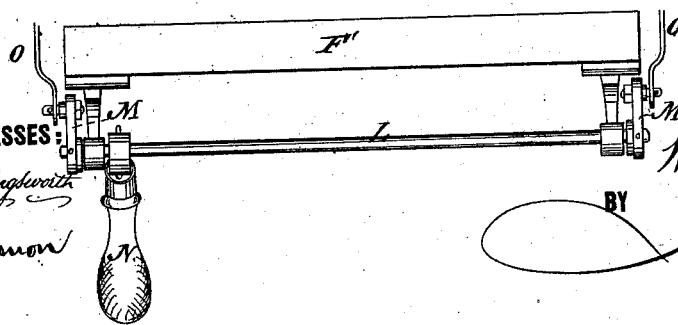
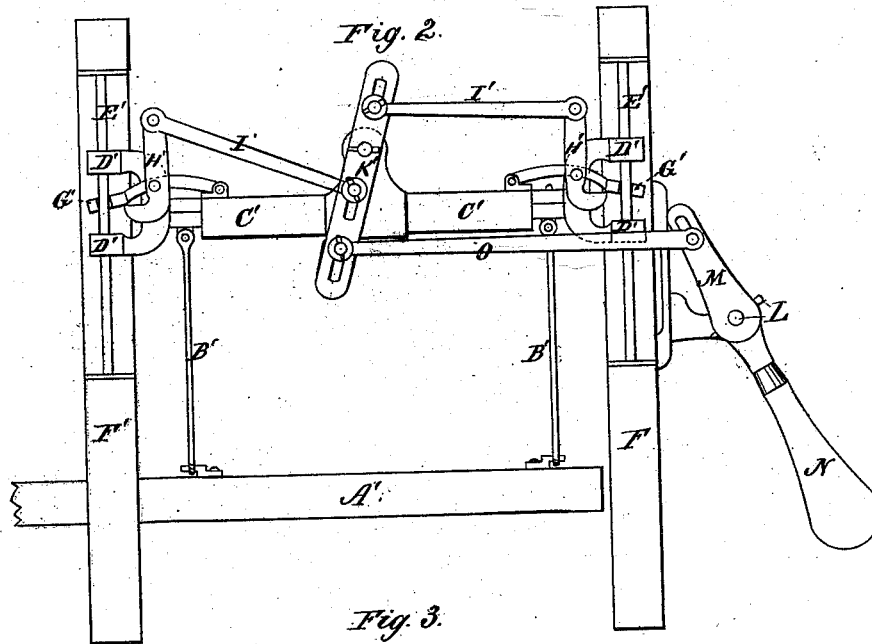
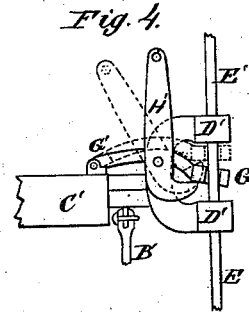
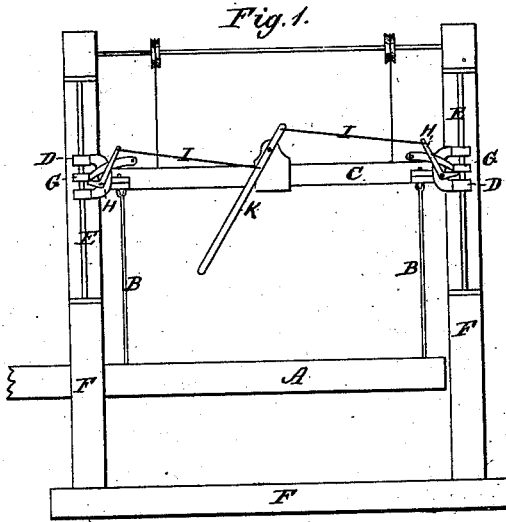

WITNESSES:
W. W. Hollingsworth
J. C. Lemon

INVENTOR:

Wm Tuggey

BY

ATTORNEYS.

UNITED STATES PATENT OFFICE.

WILLIAM TUGGEY, OF WEST RUTLAND, VERMONT.

IMPROVEMENT IN STONE-SAWING MACHINES.

Specification forming part of Letters Patent No. **203,219**, dated April 30, 1878; application filed June 27, 1877.

To all whom it may concern:

Be it known that I, WILLIAM TUGGEY, of West Rutland, in the county of Rutland and State of Vermont, have invented an improved method for operating certain devices in the invention patented to L. B. Clogston for sawing marble, which patent bears date August 25, 1874, which improvement is fully set forth in the following specification, reference being had to the accompanying drawings.

My invention is an improvement upon the marble-sawing machine for which Letters Patent No. 154,320 have been granted to L. B. Clogston.

In the accompanying drawing, Figure 1 is an end elevation, showing such parts of the Clogston machine as are required to enable my improvement to be readily understood. Fig. 2 is a similar view of said machine with my improvement attached. Fig. 3 is a plan view of a fragment of the machine, showing the application of my improvement. Fig. 4 is a detail view.

In Clogston's machine, A, Fig. 1, indicates the saws of a gang suspended by rods B from bars C, which have metallic housings or guides D, that slide on the vertical rods E attached to frame F. G G are grippers pivoted to the bars C and embracing the rods E in such a manner that they bite thereon, and prevent said bars from rising or being thrown upward at each throw of the pitman. (Not shown.) The elbow-levers H, which are pivoted to the bars C contiguous to the grippers, serve to raise the free ends of the latter, and thus relieve the bite on the rods E, and allow the bars C and saw-gang A to be raised. These levers H are operated by rods I and separate levers K, which latter are pivoted, one on each end of the machine. My invention consists in combining with such levers and rods an apparatus for operating the four grippers simultaneously, as hereinafter described.

My invention is illustrated in Figs. 2, 3, 4, in which the primed letters A' to H', inclusive, indicate the same parts as the corresponding unprimed letters in Fig. 1.

The devices which I employ consist of the horizontal rock-shaft L, having arms M, and a

hand-lever, N, rigidly connected thereto; also rods O, which connect said arms M with the levers K' that operate the grippers G G'. The said rock-shaft is mounted in suitable bearings attached to the side of frame F', and the arms M and lever N project in opposite directions from the shaft. The normal position of the parts is shown in full lines, Figs. 2, 3, in which the lever N is inclined outward from the frame F', and the grippers G' are lowered so as to bite the guide-rods E'. By seizing the free end of the lever N and pressing it inward till the lever assumes the position shown in dotted lines, Fig. 2, the diagonal central levers K' will be correspondingly reversed in position, and the grippers G' raised, as shown in dotted lines, Fig. 4, and thereby caused to simultaneously release their bite on the guide-rods E'. Such release allows the bars C' and the connected gang of saws A' to be raised, to enable the saws to begin a new cut.

It is obvious that, by throwing the lever back to its former position, the grippers will fall by gravity and bite the guide-rods, as before.

By means of my improvement, therefore, I am enabled to operate all the grippers simultaneously by a single movement of a lever, L, which is located at the side of the machine in the most easily accessible position. The labor and time required to saw a given quantity of stone is thereby greatly lessened, and the cost of the operation correspondingly diminished.

I am well aware of the employment of a rock-shaft and lever for operating various devices.

What I claim is—

The combination of the rock-shaft L, hung horizontally at the side of the machine, and the radial lever N, arms M M, and connecting-rods O O, with lever K', rods I', elbow-levers H', pivoted grippers G', and bars C', housings D', and guide-rods E', all constructed and arranged as shown and described, to operate as specified.

WILLIAM TUGGEY.

Witnesses:

WAYNE BAILEY,
J. B. SMITH.