

J. E. WOOTTEN.
 Grate for Steam-Boiler Furnaces.

No. 203,233.

Patented April 30, 1878.

Fig. 1.

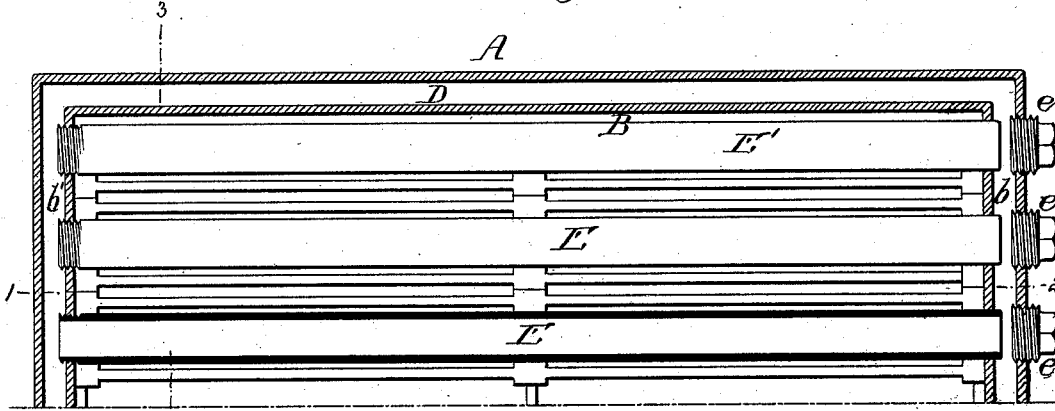

Fig. 2.

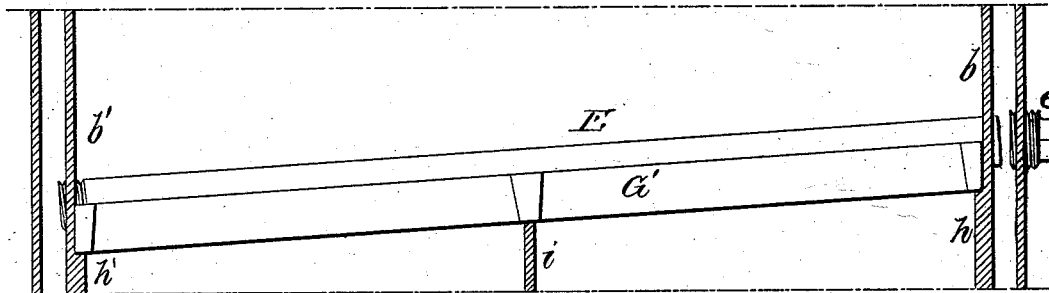

Fig. 5.

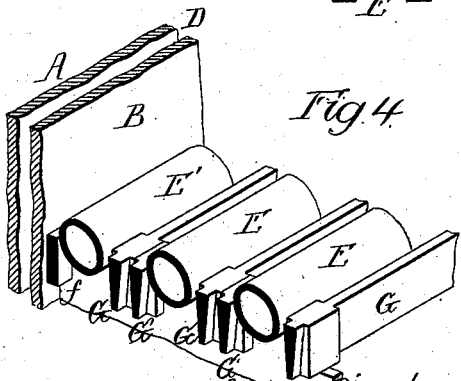

Fig. 4.

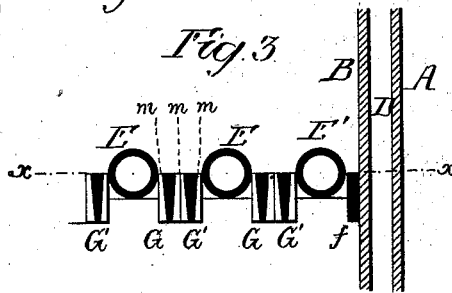

Fig. 3.

Witnesses: *Henry Smith*
John A. Deemer

Inventor
John E. Wootten
 by his Attorneys

UNITED STATES PATENT OFFICE.

JOHN E. WOOTTEN, OF PHILADELPHIA, PENNSYLVANIA.

IMPROVEMENT IN GRATES FOR STEAM-BOILER FURNACES.

Specification forming part of Letters Patent No. **203,233**, dated April 30, 1878; application filed March 28, 1878.

To all whom it may concern:

Be it known that I, JOHN E. WOOTTEN, of Philadelphia, Pennsylvania, have invented a new and useful Improvement in Grates for Steam-Boiler Furnaces, of which the following is a specification:

My invention relates to grates for burning in steam-boilers of the locomotive-type waste anthracite or pea coal; and the object of my invention is to so combine a series of tubular bars with ordinary solid bars that there shall be an extended area of opening for the passage of air through the grate to support combustion, the spaces between the bars being at the same time so narrow that particles of unconsumed coal cannot pass through them, and the tubular bars serving to shield the solid bars from the destructive effect of the heat.

In the accompanying drawings, Figure 1 is a sectional plan of sufficient of the fire-box of a locomotive-boiler to illustrate my improved grate; Fig. 2, a vertical section on the line 1 2; Fig. 3, a vertical section on the line 3 4; Fig. 4, a sectional perspective view, and Fig. 5 a sectional view of a modified form of my improved grate.

A represents the outer, and B the inner, shell of a locomotive fire-box, and D the intervening water-space.

The opposite ends of a series of tubes, E E, pass through and are secured to the front plate *b* and rear plate *b'* of the inner shell of the fire-box, these tubes, which are preferably inclined downward from front to rear, as shown in Fig 2, so as to insure the free circulation of water through them, constituting part of the improved grate.

In the front of the outer shell of the fire-box, and opposite the ends of the tubes, there are screw-plugs *ee* for closing the openings through which the tubes have been inserted into their places, the plugs being withdrawn when the said tubes have to be cleansed.

These tubes E E are at a sufficient distance apart from each other to admit of the introduction into the intervening spaces of ordinary grate-bars, two such bars, G and G', preferably of cast-iron, being shown in Figs. 1, 2, 3, and 4, and in Fig. 5 one bar in each of the spaces between the tubes. These bars, which are comparatively thin, have projections which

determine their distance apart from the tubes and from each other, the bars resting at their opposite ends on suitable ledges, *h h'*, in the interior of the fire-box, and, if desired, on an intermediate cross bearing-bar, *i*.

In Figs. 1, 2, 3, and 4, the upper edges of the bars are below the tops of the tubes, preferably so far below that they are on a line, *x x*, passing through the centers of the tubes, as shown in Fig. 3.

In burning waste anthracite coal two things are essential: first, that the volume of air for supporting combustion should be as large as possible; and, second, that the spaces between the bars should be so narrow as to prevent the small particles of coal from falling in an unconsumed condition from the grate. Ordinary grate-bars with narrow spaces between them, and made thin for the purpose of increasing the number of these spaces, would not withstand the intense heat to which they would be subjected for any considerable length of time, and tubular bars alone, if arranged with the desired narrow spaces between them, would not, owing to the size of the tubes, afford in the aggregate sufficient area for the passage of the desired volume of air, and the tubes would be so close together that the boring of the holes for their reception in the tube-sheets would destroy the integrity of the latter.

By combining tubular bars with ordinary bars, I obtain all the advantages appertaining to the former as regards durability, the desired number of narrow air-spaces, and the protection of the ordinary bars from the destructive effect of the heat.

Thus, on reference to Fig. 3, it will be seen that, by the presence between two adjoining tubular bars of two ordinary grate-bars, three narrow spaces, *m m m*, are presented, and these three spaces, being repeated throughout the width of the grate, will afford in the aggregate sufficient area for admitting the desired volume of air to support combustion. At the same time the bars G G' will be protected from the destructive effect of the heat, partly by contact with the tubular bars and partly by the exposure of the lower portion of the solid bars to the air.

In burning pea-coal or other coal of a larger

size the upper edges of the solid bars may be as high as the tops of the tubular bars, as shown in Fig. 5, where a single solid bar is arranged between contiguous tubular bars, the air-spaces being wider than in Fig. 3.

There may be more than two solid bars; but I prefer the alternating of pairs of the ordinary bars with the tubular bars, in the manner described, when the grate is intended for waste anthracite.

Each of the two end tubes E' of the series must necessarily be at a short distance from the contiguous side plate of the fire-box, thus leaving a space, which I prefer to fill or nearly fill with a plain bar, *f*.

Without claiming, broadly, a grate in which tubular bars are combined with non-tubular bars, I claim as my invention—

1. A grate in which a series of tubular bars are combined and alternate with ordinary fixed solid bars, which are in contact with the said tubular bars, all substantially as and for the purpose herein set forth.

2. The combination, substantially as described, of a series of tubular bars with ordinary fixed solid bars, the upper edges of which are below the tops and the lower edges below the bottoms of the said tubular bars, as described.

In testimony whereof I have signed my name to this specification in the presence of two subscribing witnesses.

JOHN E. WOOTTEN.

Witnesses:

HARRY A. CRAWFORD,
HARRY SMITH.