

R. W. HAMILTON.
Condenser.

3 Sheets—Sheet 1.

No. 203,337.

Patented May 7, 1878.

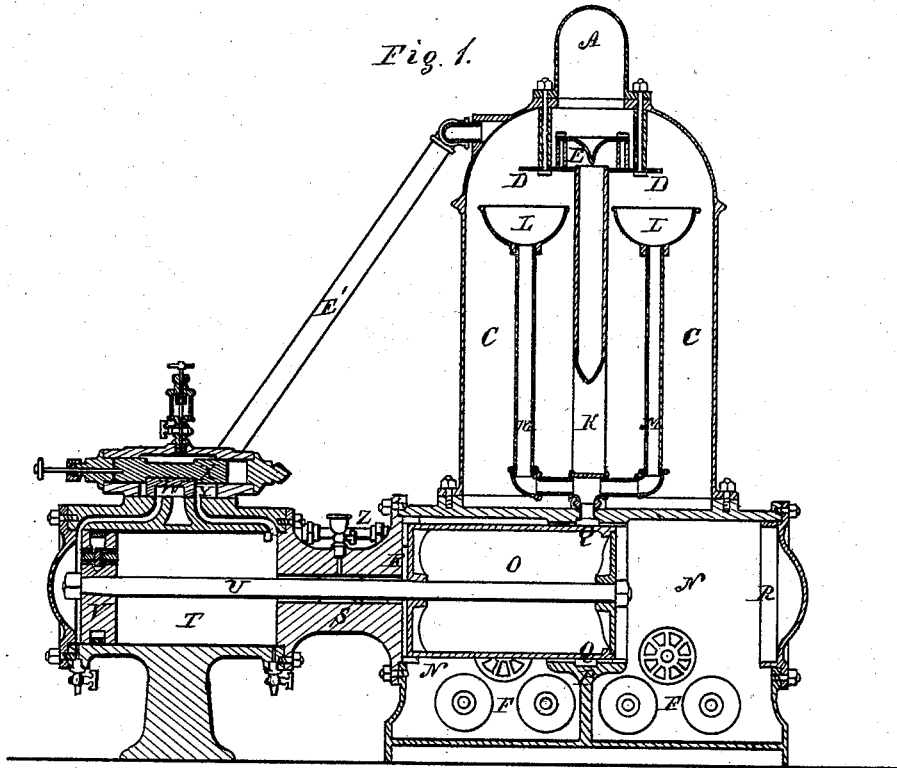

Witnesses.

Inventor.

John S. Peters
Geo D Javett

Robert W. Hamilton
by Theo. G. Ellis, attorney

R. W. HAMILTON.
Condenser.

No. 203,337.

Patented May 7, 1878.

Fig. 2.

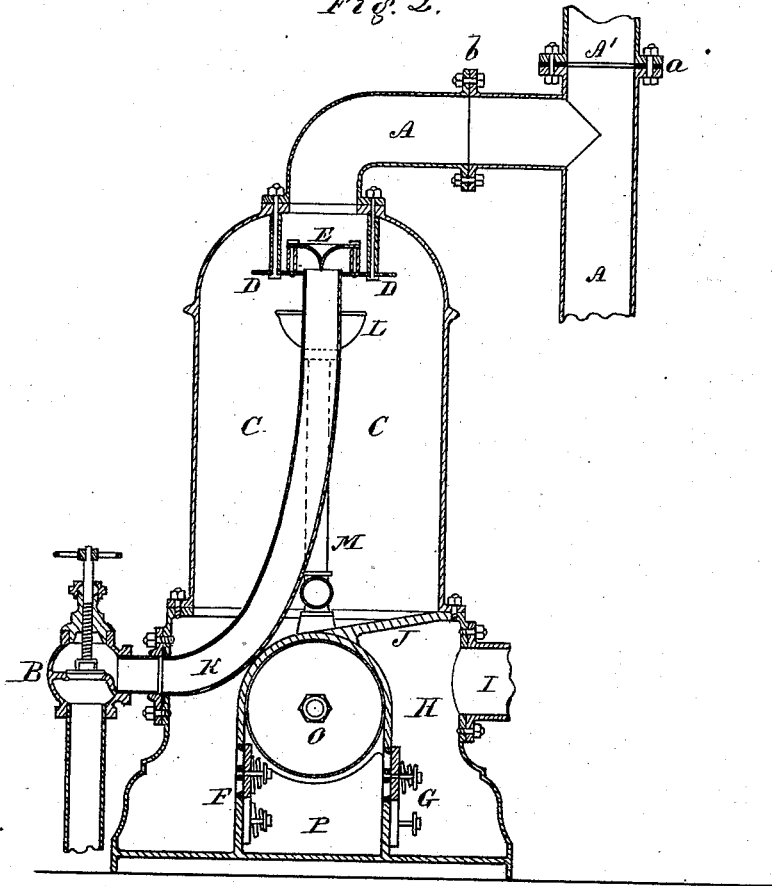

Witnesses.

Inventor.

John S. Peters
Geo D Jewett

Robert W. Hamilton
by Theo. G. Ellis, attorney

R. W. HAMILTON.
Condenser.

No. 203,337.

Patented May 7, 1878.

Fig. 3.

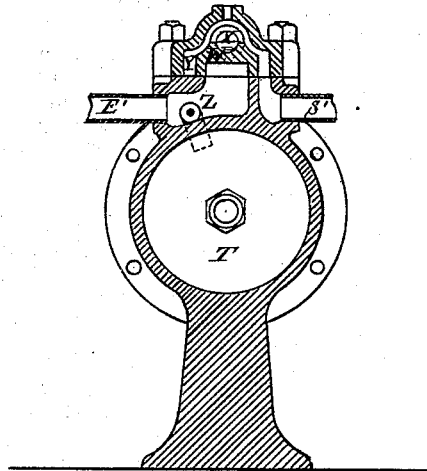

Witnesses.

John L. Peters
Geo. D. Jewett

Inventor.

Robert W. Hamilton
by Theo. G. Ellis, attorney

UNITED STATES PATENT OFFICE.

ROBERT W. HAMILTON, OF HARTFORD, CONNECTICUT.

IMPROVEMENT IN CONDENSERS.

Specification forming part of Letters Patent No. 203,337, dated May 7, 1878; application filed August 13, 1877.

To all whom it may concern:

Be it known that I, ROBERT W. HAMILTON, of Hartford, in the county of Hartford and State of Connecticut, have invented certain new and useful Improvements in Independent Condensing Mechanisms for Steam-Engines; and I do hereby declare that the following is a full, clear, and exact description thereof, whereby a person skilled in the art can make and use the same, reference being had to the accompanying drawings, and to the letters of reference marked thereon.

Like letters in the figures indicate the same parts.

My invention relates to an independent condensing mechanism, which can be attached to and used in connection with any ordinary steam-engine.

Its object is to provide a separate air-pump and condenser, which can be readily attached to the exhaust-pipe of a high-pressure or non-condensing engine without any material change in any of its parts, so that it can be used and operated as a condensing-engine.

Its object is also to provide for the working of the air-pump independently of the motion of the engine, so that its velocity may be regulated to discharge just the required quantity of water under different temperatures, and to adapt it to the power of the engine to which it is attached.

My invention consists in the construction and arrangement of the apparatus, which will be hereinafter described.

In the accompanying drawings, on three sheets, Figure 1 is a longitudinal vertical section through my improved apparatus. Fig. 2 is a vertical section through the center of the condenser, at right angles to that shown in Fig. 1. Fig. 3 is a cross-section through the steam-cylinder, passing through the steam and exhaust pipes.

As shown in the drawings, my improved apparatus consists of a condensing-chamber of a cylindrical form, surmounted by a dome-shaped top, resting upon a base likewise of a cylindrical form, through which passes the air-pump, projecting slightly at its ends, and which contains also the hot-well, valves, and valve-chamber. Outside of this base, in the line of the axis of the air-pump, is a small

steam-cylinder, taking steam directly from the boiler, for operating the plunger of the air-pump.

A is the exhaust-pipe, leading from the engine. It is provided with the interchangeable flange-plate A', which can be placed in the joint *a* when it is desired to use the condenser, and in the joint *b* when it is desired to allow the exhaust-steam to escape to the atmosphere. B is the injection-valve, to regulate the supply of cold water to the condenser C. D is a distributing plate or sprinkler upon the upper end of the internal injection-pipe K. E is a deflector, situated above the sprinkler, to prevent water from entering the exhaust-pipe. *f* are the inlet-valves, leading from the condenser to the air-pump. G are the discharge-valves, leading from the air-pump to the hot-well. H is the hot-well, and I is the pipe through which the hot water is discharged. J is a partition over the hot-well, separating it from the condensing-chamber C. L is a catch-basin, for catching a small portion of the water from the sprinkler.

M is a vertical pipe, for conducting water from the basin L to the packing-space Q around the plunger of the air-pump. There are two of these basins and pipes shown in the drawings, although one will operate. The water stands in the pipe M and fills the water-packing space Q, so that there is no escape of air from one end to the other of the air-pump.

N is the air-pump, and O is the plunger. The interior of the air-pump is divided into two chambers by the partition P, in which the plunger fits, so that by its reciprocating motion it alternately compresses the air in the two chambers and forms a double-acting pump.

R R are cushion-chambers in the ends of the air-pump. They are short hollow cylinders, of a little greater diameter than the plunger, and are for the purpose of relieving the shock at the end of the throw of the plunger, which enters into them and is gradually brought to rest.

S is a connecting-sleeve, uniting the air-pump to the steam-cylinder which operates it. T is the steam-cylinder. U is the piston-rod connecting the plunger of the air-pump with the steam-piston V. W is the steam-valve, which is thrown and operated by means of a small

valve-piston, X, operated by means of a small portion of steam taken from the steam-chest Y. S', Fig. 3, is the pipe which supplies steam to the cylinder directly from the boiler, so that the action of the air-pump is independent of the engine to which the condensing apparatus is attached.

My improved apparatus is connected to any engine that may be desired by carrying the exhaust-pipe to the top of the condenser, and providing a steam-pipe from the boiler to the steam-cylinder which works the air-pump. This converts a non-condensing engine into a condensing-engine of the most perfect and complete kind; and my improved apparatus operates in the same manner as ordinary condensers, except that, being independent of the action or power of the engine, it possesses advantages over the ordinary form of condensers.

By regulating the speed of the plunger of the air-pump it can be adapted to engines of different powers, and can be made to pump the exact quantity of water required for condensation, no matter what its temperature may be, thus saving a great amount of power usually wasted in pumping the maximum quantity at all times, as must be the case with air-pumps operated by the engine directly.

My improved apparatus can also be located in any convenient position, regardless of the

position of the engine, it being only necessary to connect the pipes, as before described.

With my improved independent condensing apparatus the vacuum can also be formed before starting the engine, thereby clearing the engine-cylinder of water and preventing accidents.

What I claim as my invention is—

1. A combined air-pump and condenser for steam-engines in which the air-pump, constructed and arranged as set forth, is contained in the base of the condenser, and which is provided with an independent steam-cylinder for operating said pump, substantially as herein described.

2. The stand-pipe M, with its catch-basin L, in combination with the sprinkler within the condenser and the water-packing space Q around the plunger of the air-pump, for supplying water to the packing-space, substantially as herein described.

3. In a condensing mechanism, the air-pump, provided with the chambers R, whereby the plunger is cushioned at the end of each stroke, substantially as and for the purpose set forth.

ROBERT W. HAMILTON.

Witnesses :

THEO. G. ELLIS,
JOHN T. PETERS.

1.250
wax