

M. C. KUMMERER & C. W. WIDNEY.
Motive Power.

No. 203,350.

Patented May 7, 1878.

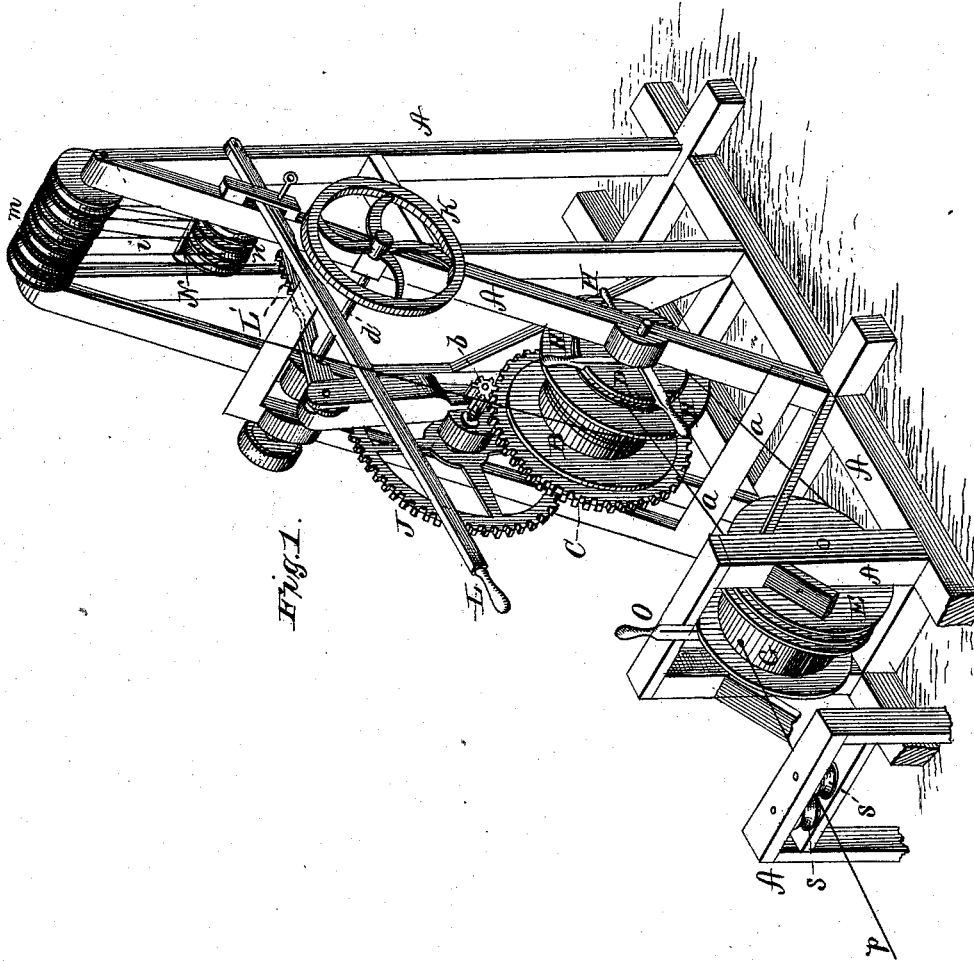

Fig. 1.

WITNESSES

Francis L. Curran
Kaukfalt

INVENTOR

Marcus C. Kummerer
Chas. W. Widney
Alexander Massey
ATTORNEYS

M. C. KUMMERER & C. W. WIDNEY.
Motive Power.

No. 203,350.

Patented May 7, 1878.

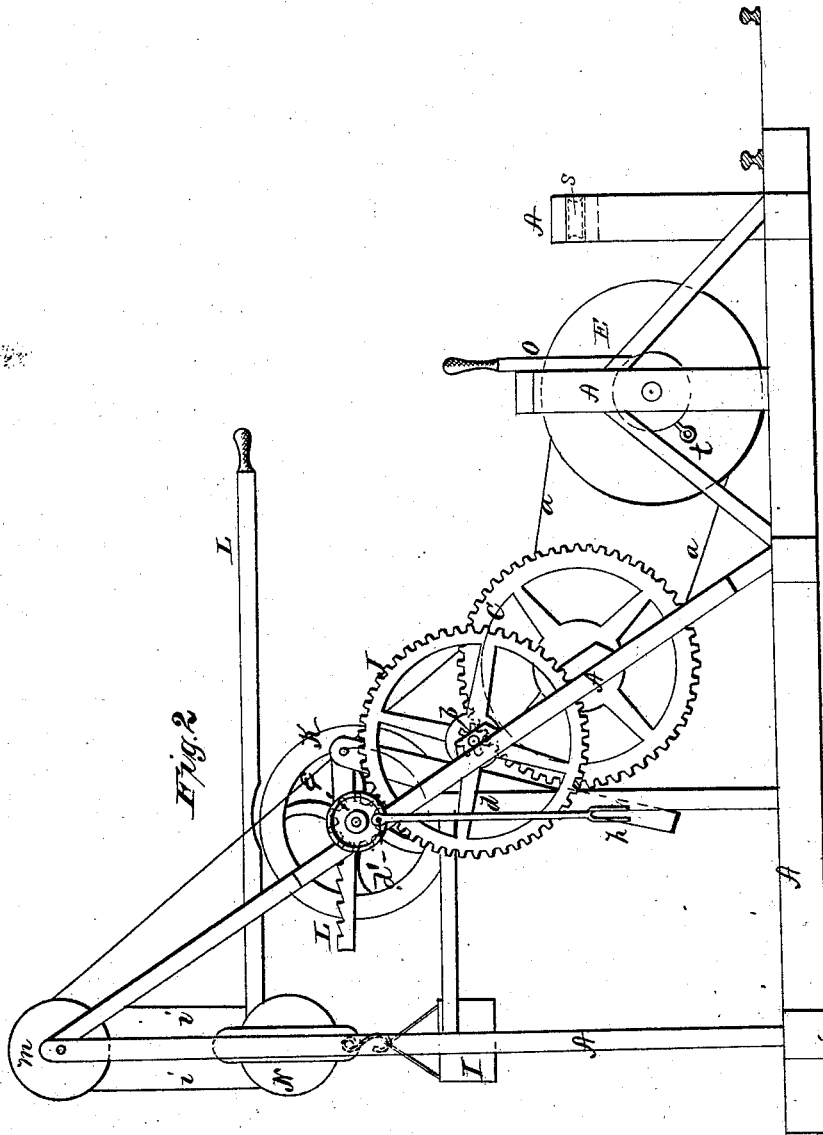

WITNESSES
Frank L. Curand
Frank Galt

INVENTOR
Marcus C. Kummerer
Chas W. Widney
Alexander Mason
ATTORNEYS

UNITED STATES PATENT OFFICE.

MARCUS C. KUMMERER AND CHARLES W. WIDNEY, OF POLO, ILLINOIS;
SAID WIDNEY ASSIGNOR TO SAID KUMMERER.

IMPROVEMENT IN MOTIVE POWERS.

Specification forming part of Letters Patent No. 203,350, dated May 7, 1878; application filed
September 12, 1877.

To all whom it may concern:

Be it known that we, MARCUS C. KUMMERER and CHARLES W. WIDNEY, of Polo, in the county of Ogle, and in the State of Illinois, have invented certain new and useful Improvements in Motive Powers; and do hereby declare that the following is a full, clear, and exact description thereof, reference being had to the accompanying drawings, and to the letters of reference marked thereon, making a part of this specification.

The nature of our invention relates to the application of weight as a motive power for pumping water for farm, railroad, or other purposes, for churning and for running other machinery; and it consists in the arrangement and combination of parts which will be more fully explained hereinafter.

In order to enable others skilled in the art to which our invention appertains to make and use the same, we will now proceed to describe its construction and operation, referring to the annexed drawings, in which—

Figure 1 is a perspective view, and Fig. 2 a side elevation, of our machine.

A represents a suitable frame-work for containing the operative portion of the machine. B represents a drum, upon one end of which is a large gear-wheel, C, and at the other end a sheave or sprocket wheel, D, to run with belt or chain, as may be deemed best. This sheave or wheel D is, by a belt or chain, *a*, connected with another sheave or sprocket-wheel, E, which runs on the shaft that passes through the secondary drum G. The drum B is provided with capstan or windlass handles H H, with which to elevate the weight I to the top of the frame.

The gear-wheel C meshes with a pinion, *b*, upon a counter-shaft, upon which is the gear-wheel J. This latter wheel meshes with a pinion, *e*, on the crank-shaft *d*. At one end of this shaft is a balance-wheel, K, and at the other end is a crank, *d'*, which can be united with a pump, churn, or other machinery by means of the pitman *h*. Over the balance-wheel K is a lever, L, for stopping the machine while under the influence of the weight I. Over the crank-shaft *d* is a notched lever, L', upon which to hang an adjustable weight to regulate or to prevent too high a speed of the machine.

At the upper end of the frame A are one or

more sheaves, *m*, to operate with corresponding sheave-wheels *n* in a frame, N, to which the weight I is fastened. One end of the rope *i*, which unites this system of sheaves, is fastened to the frame N, and, after passing around the various sheaves, the other end of said rope is fastened to the drum B.

The secondary drum G is connected to the sheave E by means of a suitable clutch, and is moved laterally on its shaft by means of a lever, O, for being thrown in and out of gear with said sheave E. This secondary drum is for the purpose of winding up the rope *i* upon the drum B by locomotive or horse power, as follows: A rope, *p*, passes through between two horizontal pulleys, *s s*, and is attached to and wound upon the drum G. This drum being thrown in gear with the sheave E, the outer end of the rope *p* is hooked to the locomotive, and can be drawn either to the right or left, as the locomotive or horse pulls, said rope unwinding from the drum G, and by the connections, as described, causing the drum B to revolve and wind up the rope *i*, raising the weight I to the top of the frame. The drum G is then, by means of the lever O, thrown out of gear with the sheave E. By now inserting a pin, *t*, through the end of the drum into its shaft, and applying a crank to the end of said shaft, the rope *p* may be wound up out of the way.

Having thus fully described our invention, what we claim as new, and desire to secure by Letters Patent, is—

1. The secondary or winding-up drum G, in connection with the pin *t*, lever O, sheave or sprocket-wheel E, and rope *p*, substantially as and for the purposes herein set forth.

2. The combination of the drum B, train of gearing, substantially as described, system of sheaves *m n*, with weight suspended therefrom, the rope *i*, pulleys D E, and secondary or winding-up drum G, with rope *p*, all substantially as and for the purposes herein set forth.

In testimony that we claim the foregoing we have hereunto set our hands this 1st day of September, 1877.

MARCUS C. KUMMERER.
CHAS. W. WIDNEY.

Witnesses:

JAMES C. LUCKEY,
UPTON S. MILLER.

*750
mxd*