

J. M. OVERSHINER & T. SHANNON. Washing-Machine.

No. 203,367.

Patented May 7, 1878.

Fig. 1.

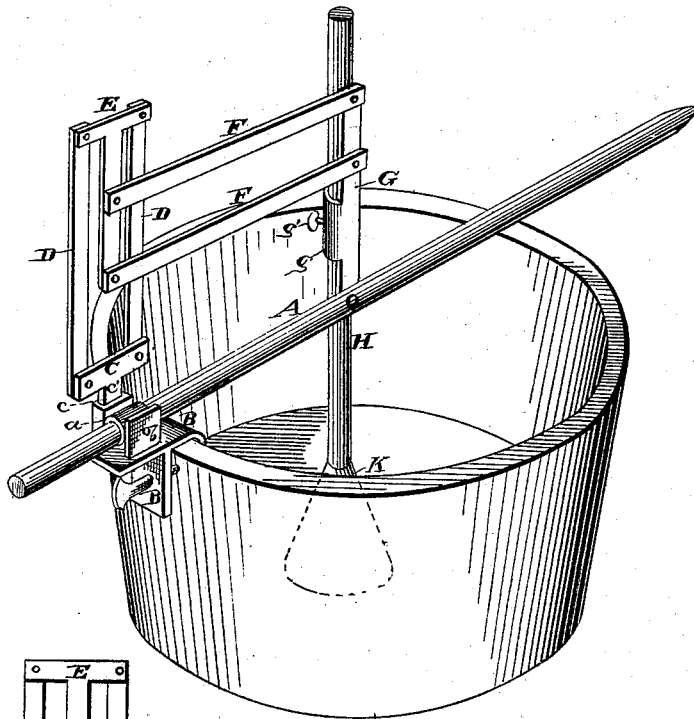
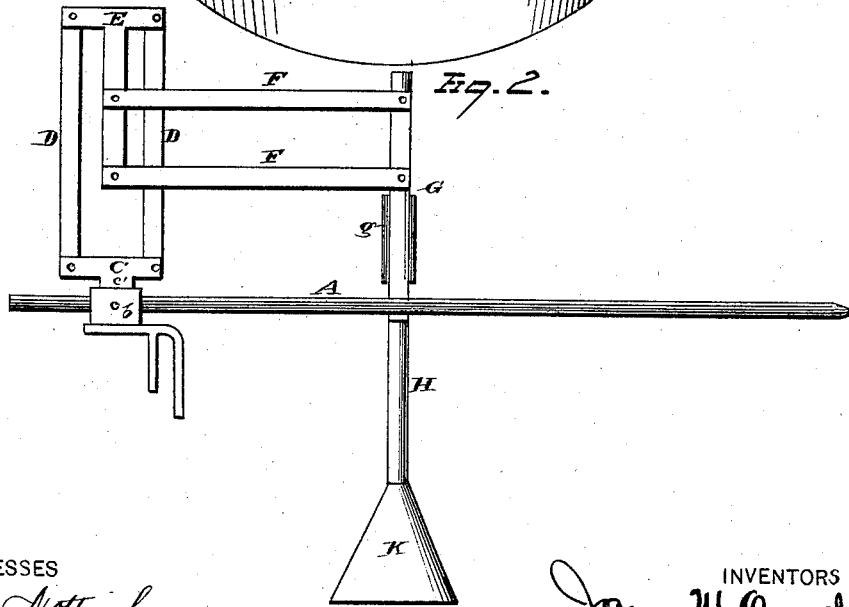

Fig. 2.



WITNESSES
Ed. J. Nottingham
J. O. McLean

INVENTORS
James M. Overshiner
and Thomas Shannon
 By *Sequett & Sequett* ATTORNEYS

J. M. OVERSHINER & T. SHANNON.
Washing-Machine.

No. 203,367.

Patented May 7, 1878.

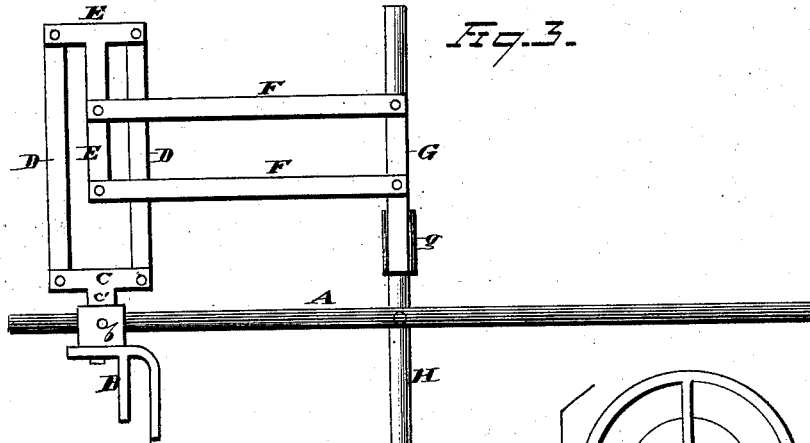

Fig. 3.

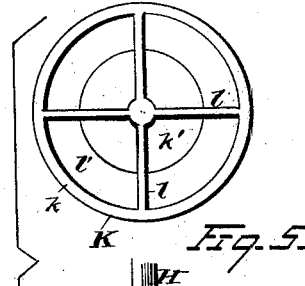

Fig. 5.

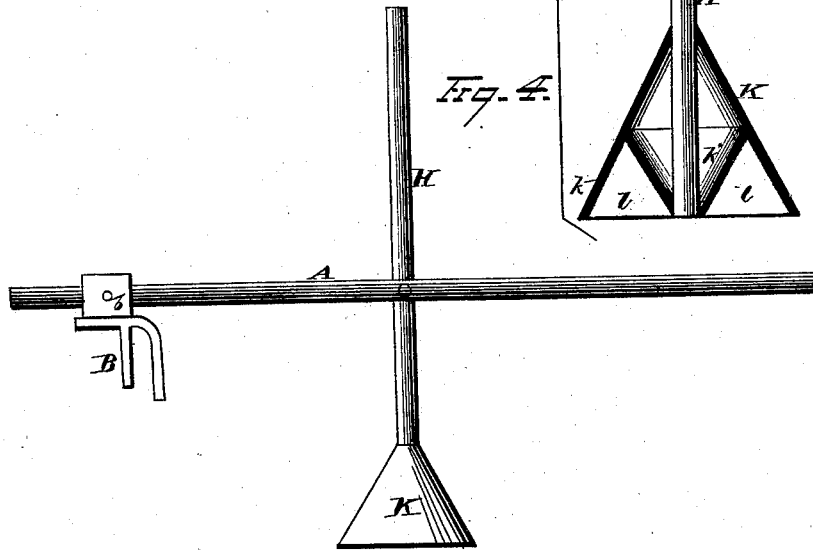

Fig. 4.

WITNESSES

Ed. J. Nottingham
J. O. McCleary

INVENTORS

James M. Overshiner
Thomas Shannon
By *Dequett & Dequett*, ATTORNEYS

UNITED STATES PATENT OFFICE.

JAMES M. OVERSHINER, OF ELWOOD, AND THOMAS SHANNON, OF
ANDERSON, INDIANA.

IMPROVEMENT IN WASHING-MACHINES.

Specification forming part of Letters Patent No. **203,367**, dated May 7, 1878; application filed
January 21, 1878.

To all whom it may concern:

Be it known that we, JAMES M. OVERSHINER, of Elwood, Madison county, Indiana, and THOMAS SHANNON, of Anderson, in the county of Madison and State of Indiana, have invented certain new and useful Improvements in Washing-Machines; and we do hereby declare the following to be a full, clear, and exact description of the invention, such as will enable others skilled in the art to which it pertains to make and use it, reference being had to the accompanying drawings, which form part of this specification.

Our invention relates to improvements in pounder washing-machines; and consists in the parts hereinafter described and claimed.

In the drawings, Figure 1 is a view, in perspective, of a tub provided with our invention. Fig. 2 is a side elevation of the device by itself. Fig. 3 is a view of a modification of the invention, whereby the apparatus designed to maintain the pounder-shaft in a constant vertical position in all the movements of the actuating-lever is adapted to be readily detached from the remaining parts. Fig. 4 shows said remaining parts as adapted to operate when the said detachable apparatus is removed. Fig. 5 represents detail views of the pounder-bowl.

One extremity of the actuating-lever A has sliding bearing within the tube or sleeve *a*, which is pivoted between the upright ears of the swivel *b*, which latter has free horizontal rotary movement upon the clamp B. One of these ears, *c*, is made with a vertical side recess, which receives the lower supporting-extension *c'* of the T-shaped bar C, while to the extremities of the lateral arms of bar C are pivoted, respectively, the lower extremities of the two parallel bars D, which latter have their upper extremities pivoted to the lateral extensions of the T-shaped bar E. This latter bar has free swinging movement from its support of the said parallel bars D, and to its central and lower longitudinal body are pivoted, respectively, the upper and lower horizontal parallel bars F. The opposite extremities of these latter bars are pivoted to the vertical bar G, which latter is provided with a sleeve, *g*, secured to its lower side body, and

which is adapted to receive the pounder-shaft H. To the extreme lower end portion of this bar G is pivoted the actuating-lever A, while the sleeve *g* is provided with a set-screw, *g'*, or similar engaging device, to allow of the vertical adjustment and maintenance of the sleeve at any desired point upon the pounder-shaft. A similar set-screw might be employed in detachably securing the lower supporting-extension of the T-shaped bar C within the recess of the swivel-ear *c*.

It is evident that this construction will admit the two sets of parallel bars, respectively—the vertical and the horizontal bars—to be quickly and easily detached from the swivel-clamp, together with the actuating-lever, as it is only necessary to vertically draw up the lower T-bar C from out its recessed swivel-ear, and to horizontally draw out the actuating-lever from the pivoted tube or sleeve of the swivel, when the entire apparatus can be removed from the tub and the swivel-clamp without disturbing the latter.

We are aware that heretofore a single standard has been used in connection with a tub-clamp, which passes through an eye in the lower extremity of the standard, while its upper extremity is connected by a swivel attachment with a system of parallel vertically-swinging bars, the said standard being detached from the tub by removing the clamp from the latter and drawing it out of the eye of the standard. Such construction we disclaim.

The two sets—respectively vertical and horizontal—of parallel bars, serve to preserve the pounder-shaft constantly in a vertical position during the operation of washing, so that the pounder is caused to be brought down upon the clothes in a proper operative position at all times.

In Fig. 3 of the drawings we have shown the actuating-lever as being pivoted to the pounder-shaft direct, and not secured at all to the sleeve-bar G. This enables the said bar, together with its connecting-bars F, to be readily removed from the pounder-shaft, and to leave the lever still attached to the latter; and, since the parallel vertical bars D are readily removable from the swivel-clamp, it is apparent that

these two sets of bars, together with the upper and lower T-shaped bars C and E, may be detached from or connected to the remaining operative parts of the machine, as may be desired.

The advantage of this construction arises from the fact that it is frequently desirable to use the pounder-shaft, the actuating-lever, and the swivel-clamp, as three main parts of the machine, free from any device or apparatus for causing the pounder-shaft to be maintained in a constant vertical position; and, as it is only necessary to the operation of washing by lever-pounding that there should be these three parts just mentioned, the said detachable apparatus for holding the pounder-shaft in a vertical position may be used or not, as may be desirable in any particular instance.

We are aware that the actuating-lever has been heretofore connected to the pounder-shaft of a washing-machine in such a manner as to permit of the ready disconnection of the two, and also so as to allow of the vertical adjustment of the lever relative to the pounder-shaft. Such a broad construction of our invention we do not claim.

In Fig. 5 of the drawings we show two views of our peculiar pounder-bowl K, which is made by connecting the large conical shell *k* with the smaller inverted shell *k'*, and providing a series of radial plates or braces, *l*, which connect the lower inner side of the larger shell with the outer side of the smaller shell. This construction provides a pounder-bowl of shape as shown, having its bottom concave or mouth-shaped, and divided into a number of coniform recesses or cups, *l'*, each recess or cup having its largest transverse area at its bottom, and diminishing as the top is approached. These braces make the pounder very strong, and provide against the strain imposed upon it in the operation of washing, it being understood that, instead of the four braces shown, there may be either a less or a greater number thereof.

Having fully described our invention, what we claim as new, and desire to secure by Letters Patent, is—

1. The combination, with the tub-clamp, of the parallel vertical bars, provided with the T connecting-piece at their lower extremities, which has detachable engagement with said clamp, substantially as set forth.

2. The combination, with the swivel-clamp which secures the attachment to a tub, of the parallel vertical bars, pivoted at their lower extremities to a connecting-piece, which latter has detachable engagement with said clamp, substantially as set forth.

3. The combination, with the two systems, respectively, of parallel vertical bars and parallel horizontal bars, of the connecting T-bar, to which the same are severally pivoted, and the bar which engages the same with the lever and the pounder-shaft, substantially as set forth.

4. The combination, with the actuating-lever and pounder-shaft, of the connecting-bar provided with a sleeve which embraces the latter, said bar being pivoted to the respective connecting extremities of the horizontal parallel bars, and to the actuating-lever, substantially as set forth.

5. The combination, with the parallel horizontal bars, the pounder-shaft, and actuating-lever, of the intermediate connecting-bar, formed with a sleeve which embraces said pounder-shaft, and is adapted to be vertically adjusted thereon, substantially as set forth.

6. The combination, with the actuating-lever, pounder-shaft, and parallel horizontal bars, of the connecting-bar, pivoted, respectively, to said lever and horizontal bars at opposite end extremities, and formed with an intermediate sleeve, which engages with the pounder-shaft, substantially as set forth.

7. The combination, with the tub-clamps, one of whose ears is formed with a vertical recess, of the T-bar which connects the lower extremities of the parallel vertical bars, and is adapted to slide in and out of said recessed ear, substantially as set forth.

8. The combination of the two systems of horizontal and vertical parallel bars, respectively pivoted to the connecting T-bar, the sleeve-bar which connects with the pounder-shaft, the actuating-lever, and the lower connecting T-bar which engages with the tub-clamp, substantially as set forth.

9. In a pounder washing-machine, the combination, with the parallel horizontal bars, of the vertical bar provided with the sleeve in which the pounder-shaft is adapted to have vertical adjustment, substantially as set forth.

10. In a pounder washing-machine, the combination of the two systems of parallel bars, respectively adapted to swing in a vertical and a horizontal plane, and the vertically-swinging connecting-bar, substantially as set forth.

In testimony that we claim the foregoing we have hereunto set our hands this 14th day of January, 1878.

JAMES M. OVERSHINER.
THOMAS SHANNON.

Witnesses:

G. M. OVERSHINER,
GEO. M. BALLARD.