

G. M. PHELPS. Polarized Electro-Magnet.

No. 203,369.

Patented May 7, 1878.

Fig. 2.

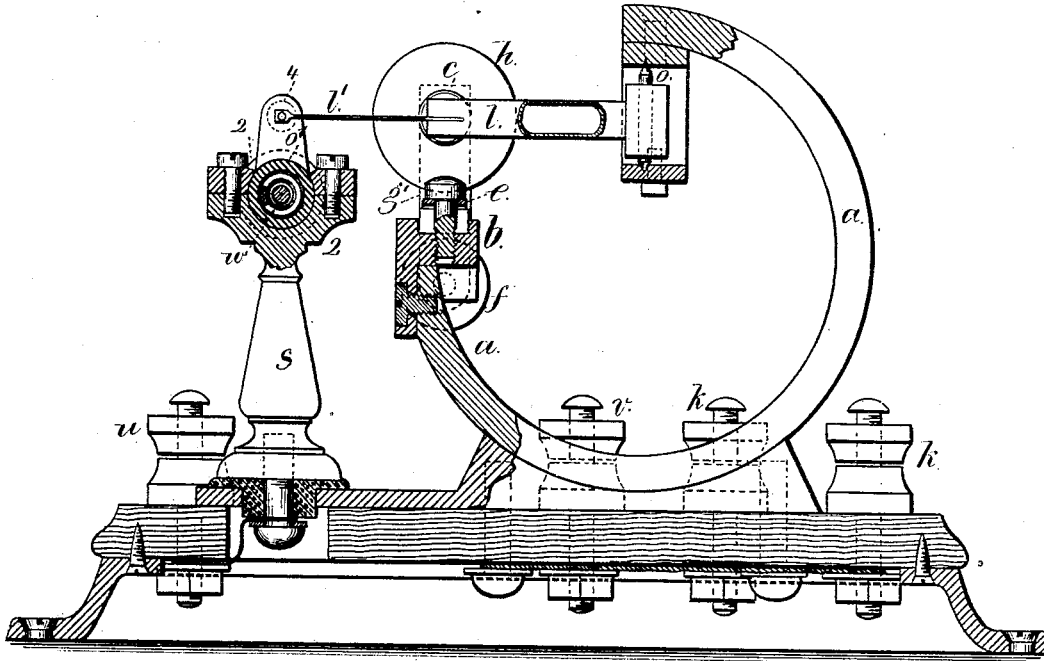
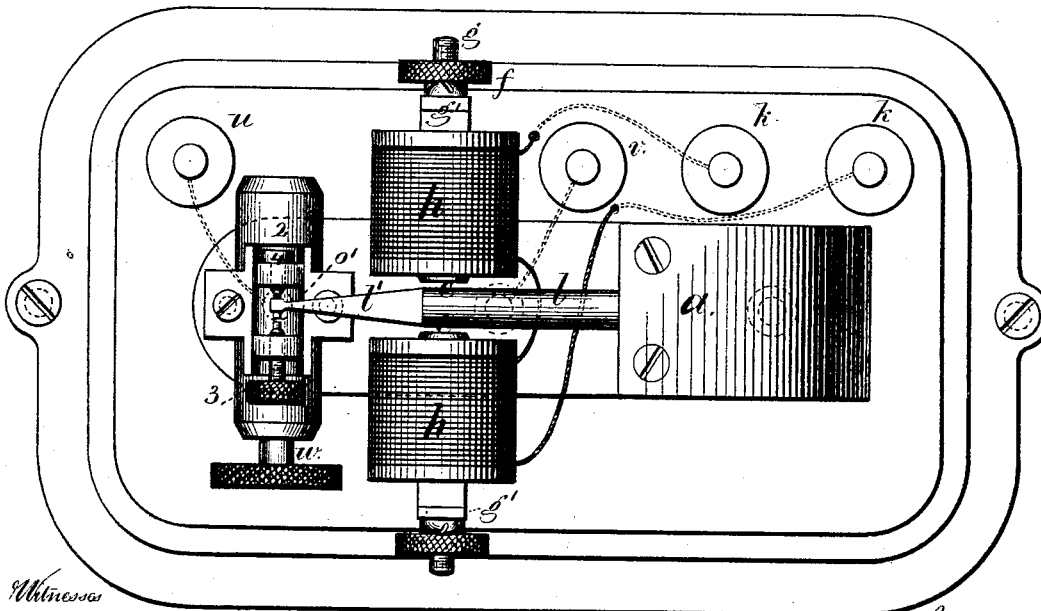

Fig. 1.



Witnesses

Charles Smith
Geo. T. Pinckney

Inventor

George M. Phelps.
per Lemuel W. Serrell

G. M. PHELPS.
Polarized Electro-Magnet.

No. 203,369.

Patented May 7, 1878.

Fig. 3.

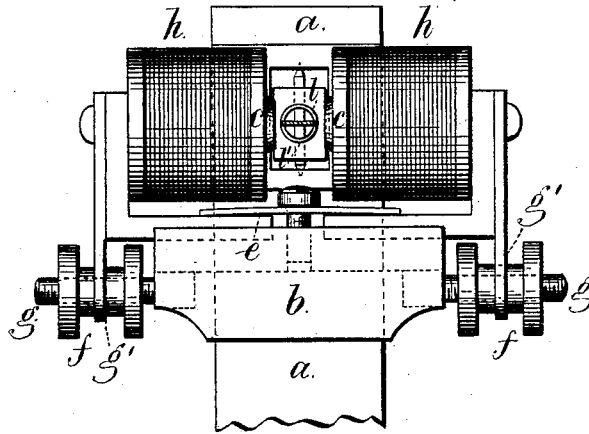
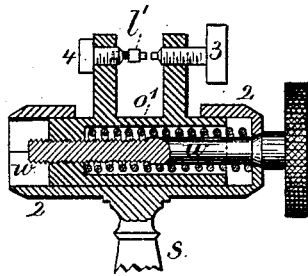

Fig. 4.



Witnesses

*Chas. H. Smith
Geo. T. Pinckney*

Inventor

*George M. Phelps.
per Lemuel W. Ferrall
att'y*

UNITED STATES PATENT OFFICE.

GEORGE M. PHELPS, OF BROOKLYN, NEW YORK.

IMPROVEMENT IN POLARIZED ELECTRO-MAGNETS.

Specification forming part of Letters Patent No. **203,369**, dated May 7, 1878; application filed June 27, 1877.

To all whom it may concern:

Be it known that I, GEORGE M. PHELPS, of Brooklyn, in the county of Kings and State of New York, have invented an Improvement in Polarized Electro-Magnets for Telegraphic and other purposes, of which the following is a specification:

In polarized electro-magnets now used in duplex and quadruplex telegraphy the soft-iron cores of the electro-magnet have lateral adjustable prolongations called "shoes," for the purpose of extending the poles to the proper vicinity of the polarized armature.

The prolongations are found to seriously impede the magnetic charge and discharge of the iron cores, thus reducing the effectiveness of the instrument.

The armature has been a thin piece of soft iron, with a brass extension-piece for the local contact and stop points, the flat sides of the iron facing the lateral prolongations or shoes; hence the armature is liable to spring or bend by the force of the magnetism, and produce a false movement and injure its performance.

My invention is to remove the defects described; and the same consists in an electro-magnet attached to one pole of a permanent magnet, with the ends of the cores facing each other, so that the two cores become polarized by the permanent magnet, and the armature is tubular and directly between the cores, and hinged to the opposite pole of the permanent magnet, and polarized thereby.

This polarized electro-magnet may be employed wherever available. It is, however, especially adapted to operate a circuit contact-point, because the polarized armature is moved by a very weak or delicate current in the helices around the soft-iron cores, which current tends to neutralize or reverse the polarity of one of the cores and increase that of the other, so long as the current is operative in the helices, and when it ceases the cores return to their normal polarized condition.

In the drawing, Figure 1 is a plan of the polarized electro-magnet. Fig. 2 is an elevation of the same, partially in section. Fig. 3 is a front view of the magnet and adjustable cores, and Fig. 4 is a section of the circuit-closing adjuster.

The permanent magnet *a* is, by preference,

a section of a ring, at one end of which is a soft-iron piece, *b*, formed with a groove that receives the adjustable supports of the soft-iron cores *c*. These supports are retained by the ends of the spring-clamp *e*, and the cores *c c* may be adjusted farther from or nearer to the armature by the screw-nuts *ff*, that are upon screws *g*, and act at each side of the pending brass pieces *g'*.

The cores *c* face each other, and, by the adjustment aforesaid, the distances between the cores and the armature are determined. These cores are polarized by the magnetism from the permanent magnet *a*. There are helices *h* around these cores *c c*, which helices are connected in the electric circuit through the binding-screws *kk*, and the cores, helices, and connections between the cores form a single electro-magnet.

The armature *l* is sustained by the pivoted axis *o*, that passes through the end of the armature, which is made square for the purpose of presenting surface for magnetization from the permanent magnet. Said armature is preferably a soft-iron tube, to insure strength and lightness, and said tube lies between the ends of the cores *c c*, and has attached to it a brass extension-lever, *l'*, for the local contact or stop points, or for any other purpose.

By this construction great strength and stiffness are obtained in the armature without increasing its weight, and there is no risk of the metal springing, bending, or giving a false signal.

The adjusting-slide 2 is supported by the insulated standard *s*, to which one wire from the binder *u* of a local or other circuit is connected, and the other wire of the same circuit is connected with the binder *v* and permanent magnet *a*, so that the local circuit passing through *a* is opened and closed between the armature-extension *l'* and screw 3, which are preferably tipped with platina, and the back point 4 is insulated.

By adjusting the cylinder *o'* endwise within the tube 2 by the screw *w*, Fig. 4, the polarized tongue can be moved to a place midway between the cores *c c*, or nearer to one core or the other, so as to respond to the attractive force of the electro-magnet when the polarity of one core is intensified and the other weak-

ened or reversed by the electric current passing through the helices *h*.

By this construction the parts can be easily and accurately adjusted, and there is great delicacy in the action of the polarized magnet, so that a reliable response is obtained from a weak current, or the instrument can be adjusted to respond only to a more powerful current, according to the proximity of the cores to the polarized armature.

This polarized electro-magnet is adapted to many uses in the arts, but is especially useful as a circuit-closer for relay-instruments in quadruplex and multiplex telegraphs.

I claim as my invention—

1. An electro-magnet having the cores facing each other and polarized by a permanent magnet, substantially as described.

2. The combination, with the tubular armature in a polarized electro-magnet, of a flat extension, *v*, substantially as set forth.

3. An electro-magnet having the cores facing each other and polarized by one pole of the permanent magnet, in combination with an armature attached to and polarized by the other pole of the permanent magnet, substantially as specified.

Signed by me this 21st day of June, A. D. 1877.

GEO. M. PHELPS.

Witnesses:

GEO. T. PINCKNEY,
WILLIAM G. MOTT.