

M. E. CARD.
Ball-Target Thrower.

No. 203,416.

Patented May 7, 1878.

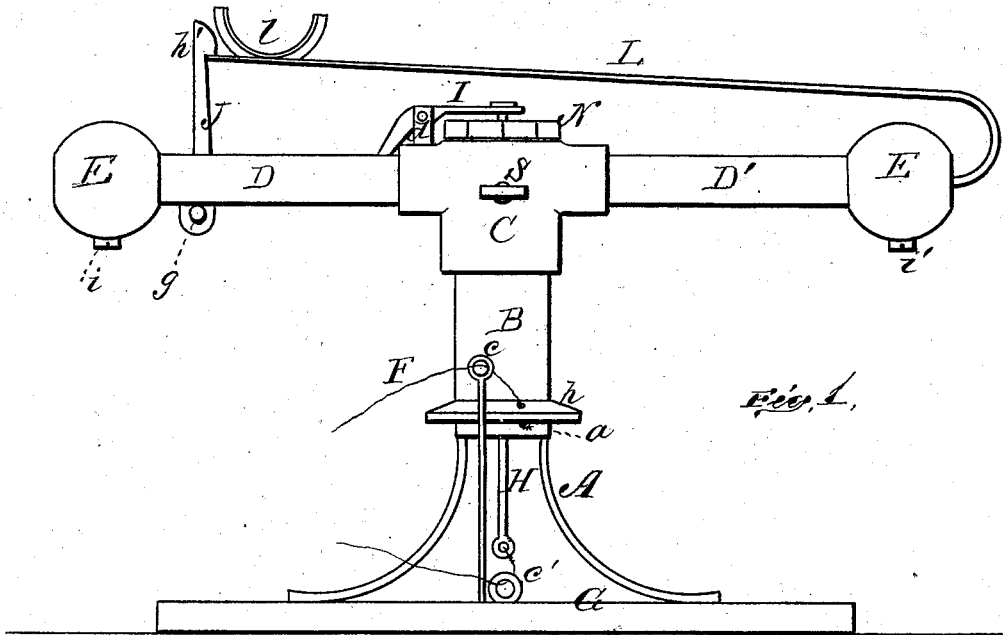

Fig. 1.

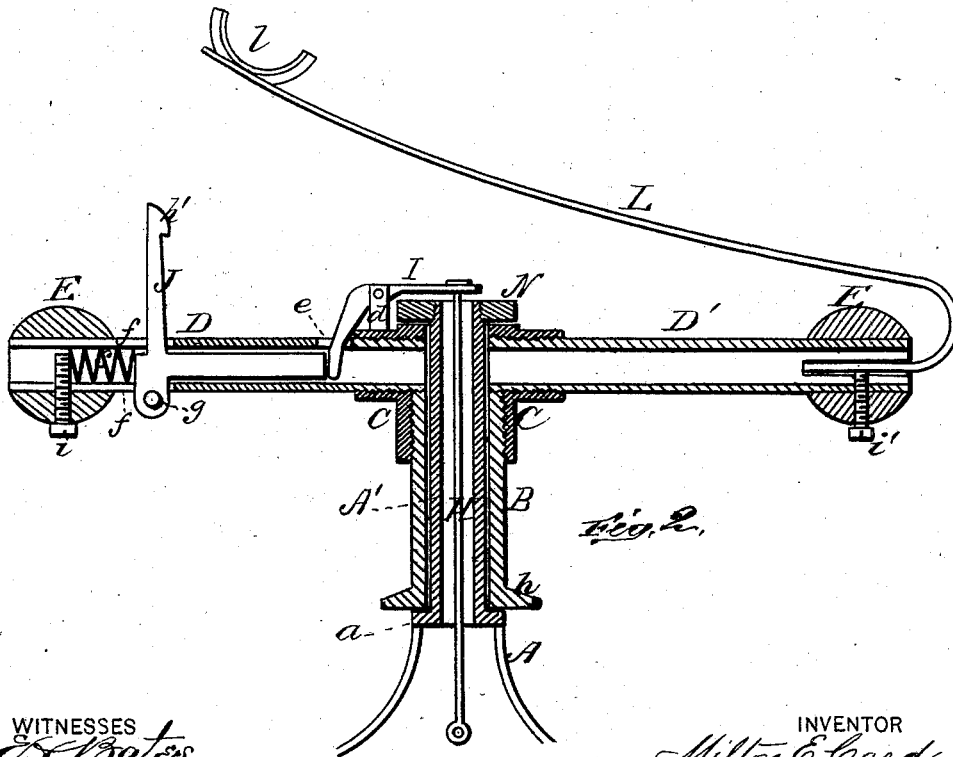

Fig. 2.

WITNESSES
J. Bates
J. Yellasi.

INVENTOR
Milton E. Card,
by E. W. Anderson,
ATTORNEY

UNITED STATES PATENT OFFICE.

MILTON E. CARD, OF CAZENOVIA, NEW YORK.

IMPROVEMENT IN BALL-TARGET THROWERS.

Specification forming part of Letters Patent No. 203,416, dated May 7, 1878; application filed March 9, 1878.

To all whom it may concern:

Be it known that I, MILTON E. CARD, of Cazenovia, in the county of Madison and State of New York, have invented a new and valuable Improvement in Rotary Glass Ball Traps; and I do hereby declare that the following is a full, clear, and exact description of the construction and operation of the same, reference being had to the annexed drawing, making a part of this specification, and to the letters and figures of reference marked thereon.

Figure 1 of the drawing is a representation of a side view. Fig. 2 is a sectional view.

This invention has relation to improvements in glass-ball traps for sportsmen's use.

The object of the invention is to construct a trap to which a more or less rapid rotary motion may be imparted, so that the direction of the flight of the ball will be rendered uncertain, thereby simulating that of a startled bird, and the difficulty of striking the same greatly increased.

In the accompanying drawing, the letter A designates a tripod or base, supporting at its upper part a tubular metallic post, A', of cylindrical form. This post is screw-threaded at its upper end, and is provided near its lower end with an annular bearing, a.

B represents a tubular metallic sleeve, that is passed over the post A and rests upon the bearing-flange a. This sleeve has at its lower end a projecting flange, h, and has secured to its upper end an ordinary three-branched gas-fitter's coupling-pipe, C, into the horizontal arms of which are screwed the tubular arms D D', of equal length, and provided at its extremity each with a ball, E.

The space upon the sleeve B between the flange b and the lower edge of the coupling C, constitutes a drum, to which is rigidly secured, in any suitable manner, a cord, F, which is wound on the said sleeve by imparting a rotary motion to the sleeve by twirling the arms D.

The cord F is secured to the sleeve near the flange h, and is carried through a guide, e, thence through a guide, e', on the base G, and is rigidly secured to the lower end of a rod, H, extending up the bore of the post A', and pivoted to the power end of a vertically-vi-

brating bell-crank lever, I, having its fulcrum on the arm D in standards d erected thereon. The weight-arm of this lever extends down through a slot, e, into the interior of the arm D, and is in contact with the end of a right-angular catch, J, one branch of which is in the bore of the said arm, and the other projects above and below through longitudinal slots f in the upper and lower faces of the arm aforesaid, being prevented from upward displacement by means of a pin, g, extending through the end of the said catch, projecting through the lower slot f of the said arm D.

The vertical arm of the catch J has a barbed head, h, and its horizontal arm is held in contact with the lever I by a spring, s, compressed between the said vertical arm and a screw-stop, i, extending diametrically through the arm D aforesaid, as shown in Fig. 2.

L represents a strip-spring, of recurvate form, the short arm of which is passed into the open end of the arm D', and is secured thereto by means of a set-screw, i'. This spring has upon its free end a cup, l, into which the ball is placed, and when thrust down becomes engaged with the barbed head h. The cord F is wound upon the drum by twirling the arms D D', and the ball having been placed in the cup, the attendant seizes upon the said cord near the guide e and draws forcibly thereon, retaining his hold until the lower branch thereof, which passes through the guide e' and is secured to the draw-rod H, is tautened. The ball-cup revolves rapidly and in a horizontal plane, owing to the unwinding of the said cord, and the catch is disengaged from the spring, allowing it to react and project the ball.

The rotary portion of the trap is prevented from flying off of the tubular spindle A during its rotation by means of a nut, N, screwed upon the upper end of the said spindle, and the said rotary portion is locked to the post A, thus preventing its rotation, by means of a set-screw, S, passing through the coupling C and bearing against the said post.

During the rotation of the trap, at the moment the cord F tautens, the ball is projected by the spring in a direction impossible to foresee, thus closely imitating the uncertain di-

rection of the flight of a startled bird and rendering the striking of the balls much more difficult.

What I claim as new, and desire to secure by Letters Patent, is—

The combination, with the tubular vertical spindle, the sleeve rotating thereon and having the tubular arms D D', the right-angular catch J, having one branch in arm D, and the other projecting through slots therein, and the spring s, of the projecting spring L, attached to arm D' and adapted to engage catch J, the

angular lever I engaging the said catch, the rod H extending through the spindle, and the cord F attached at one end to said rod and at the other to the said sleeve, substantially as specified.

In testimony that I claim the above I have hereunto subscribed my name in the presence of two witnesses.

MILTON E. CARD.

Witnesses:

CHAS. M. POTTER,
CHAS. B. CANNON.