

J. EVANS
 Lathe Stone Chuck.

No. 203,436.

Patented May 7, 1878.

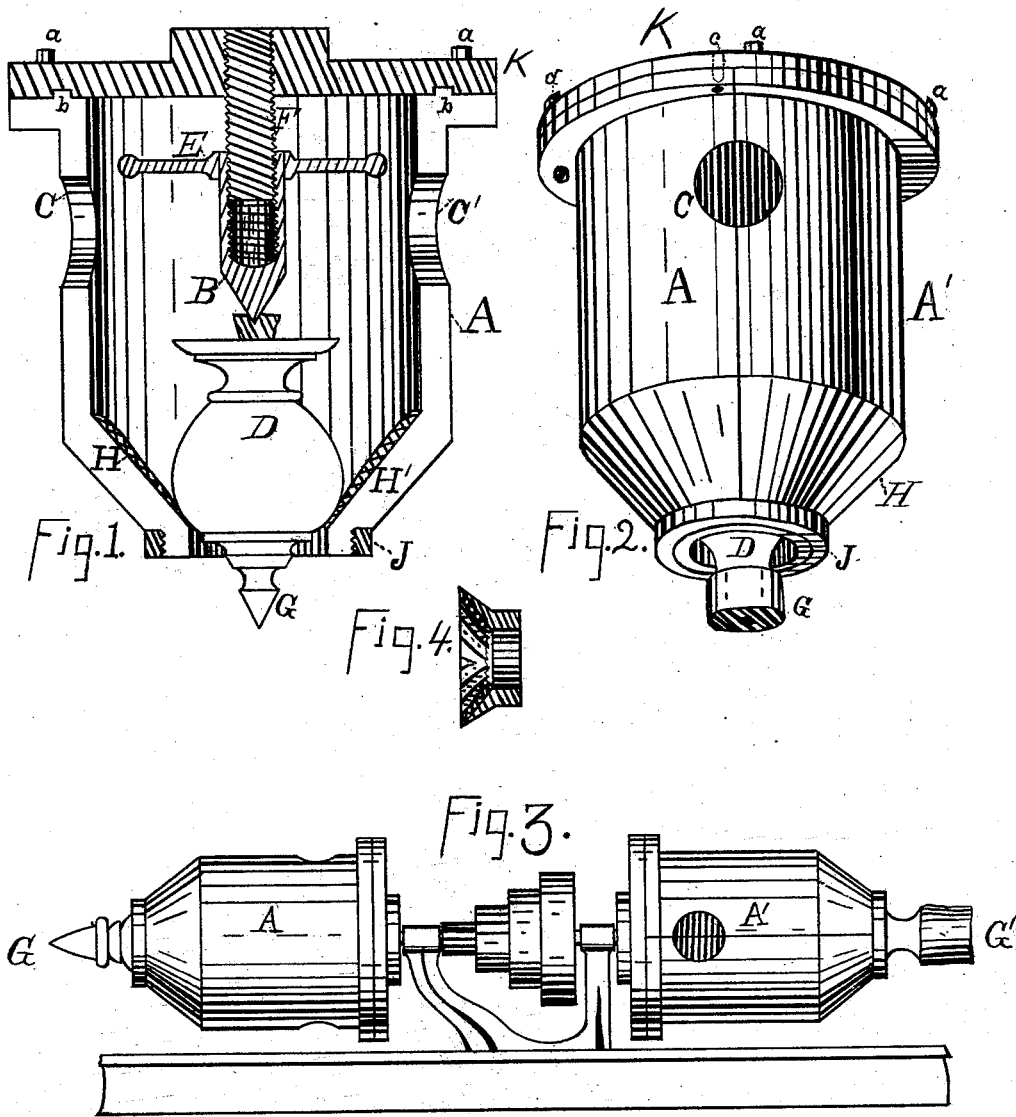

Witnesses:

Alfred Way.
Charles Butler.

Joseph Evans, Inventor,

By

Geo. C. Tracy & Co., Attorneys.

UNITED STATES PATENT OFFICE.

JOSEPH EVANS, OF CLEVELAND, OHIO.

IMPROVEMENT IN LATHE STONE-CHUCKS.

Specification forming part of Letters Patent No. **203,436**, dated May 7, 1878; application filed February 28, 1878.

To all whom it may concern:

Be it known that I, JOSEPH EVANS, of Cleveland, in the county of Cuyahoga and State of Ohio, have invented a new and Improved Lathe Stone-Chuck; and I do hereby declare that the following is a full and exact description of the same, reference being had to the accompanying drawings, and to the letters of reference marked thereon.

This invention is designed to be attached to a lathe as a chuck for holding a stone or marble vase or similar article while turning and finishing the end, which cannot be done in the manner commonly pursued without great liability to breakage. My device is so constructed as to be readily attached to any lathe used for these purposes, and greatly facilitates ease and rapidity of operations. By constructing it in half-sections, as shown, I also secure the utmost freedom in obtaining access to the interior, for the purpose of inserting the article to be turned, or in changing any of the working parts, as further described. My device, by the employment of adjustable parts, is also adapted to a great variety of sizes of work, and is practically self-centering.

In the drawings, Figure 1 is a sectional view, showing the interior construction of the chuck and its parts. Fig. 2 is an exterior perspective view. Fig. 3 shows two of the devices as they would appear mounted upon a lathe and containing work. Fig. 4 is a reducer.

In Fig. 1, A is the barrel or body of the chuck, showing one half-section, the barrel or body being divided to allow the removal of the upper half to obtain access to the inside, for the purpose of placing the article to be turned in position. B is the adjustable center, on which the article is held. D is a vase as it would appear within the chuck and in position for operation. E shows a hand-wheel for adjusting the pivot B upon the threaded stationary center F, to drive the work forward into the bevel-neck, and upon the cushions H H' permanently cemented thereto. C C' are arm-holes for reaching the hand-wheel, to adjust the work to center on the pivot B. K is the head, upon which the two sections of the barrel are bolted, one half permanently, the

other being removable to permit access to the interior. *a a* are bolts inserted in flanges at K, for the purpose of attaching the sections to the head A, the two parts being slotted and recessed at *b b*, to insure accuracy of the parts in coming together. J is a collar, screwed upon the throat of the bevel-neck H.

To operate the device, the upper section A, Fig. 2, is removed by unscrewing the collar J and taking out the bolt *d*, when it can be lifted from the dowel-pins *c*, one of which is placed at each opposite side in the head K. The work can then be placed within the half-section A', and the section A returned to its position and fastened by the bolt *d* and collar J. The adjustment to center is effected by the hand-wheel E and pivot B through the arm-holes C C', the work being crowded against the cushion H, and adjusted at the neck. The ease with which this may be done is one of the most important advantages of my invention. The end of the vase will then appear as in G, Fig. 2, and may then be turned to the shape designated by letter G, Fig. 1.

On the stationary center F may be screwed pivots B of various lengths, to adapt the device to different sizes of work.

Fig. 4 shows a reducer, designed to be placed within the bevel-neck H, for the purpose of decreasing the size of orifice, provided that in the original machine it is too large for the work in hand.

In Fig. 3, A' is my improved chuck, mounted upon a lathe, and holding unfinished vase G'. A is the same, showing the end finished, as at G.

I am aware that a chuck for turning and finishing stone vases has already been patented consisting of an enlarged centering-head, into which the vase is set upon a centering-spud, and an open-ended cap, adapted to fit over the vase and to turn upon screw-threads formed on the outside of the barrel of the head; and I hereby disclaim such device as making any part of my invention.

Having thus described my invention, what I claim as new, and desire to secure by Letters Patent, is—

1. A chuck for the purpose set forth, the

body of which is divided longitudinally into two parts, A A', substantially as described and shown.

2. In a chuck for the purpose set forth, the combination of the longitudinally-divided body with the adjustable center within such body, substantially as described and shown.

3. In a chuck for the purpose set forth, the stationary screw-threaded center F, inclosed in the body of the chuck, adapted to receive adjustable centers B of various lengths, substantially as described and shown.

4. In a chuck for the purpose set forth, the

elastic cushion H' in the bevel-neck of the chuck, substantially as described and shown.

5. In a chuck for the purpose set forth, the combination, with the divided body, of the reducer, Fig. 4, adapted to be placed in the opening in the end of the body, substantially as described and shown.

This specification signed and witnessed this 22d day of February, 1878.

JOSEPH EVANS.

Witnesses:

EDW. S. TRACY,
OSCAR BALZER.