

T. E. & J. H. HAYES.  
Vehicle-Top.

No. 203,450.

Patented May 7, 1878.

Fig. 1.

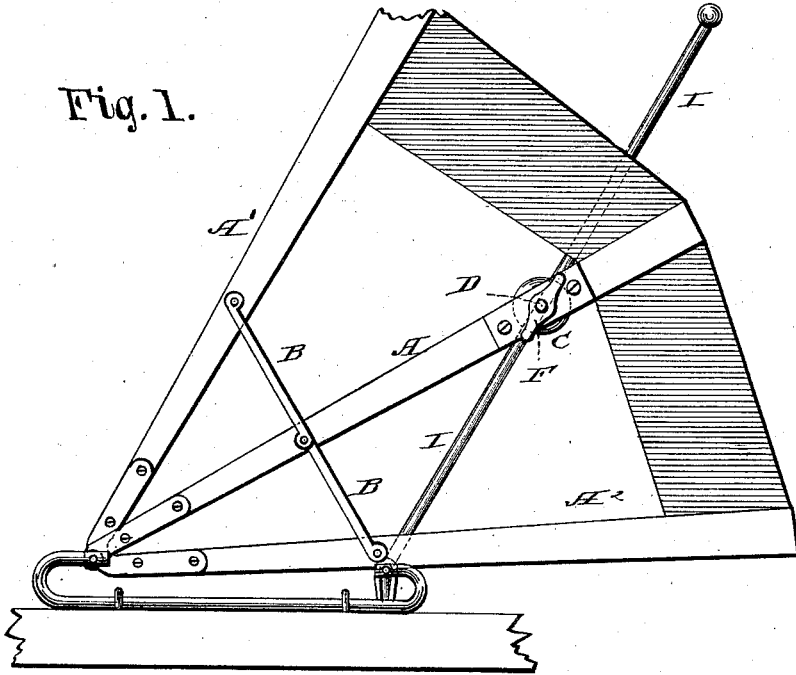

Fig. 2.

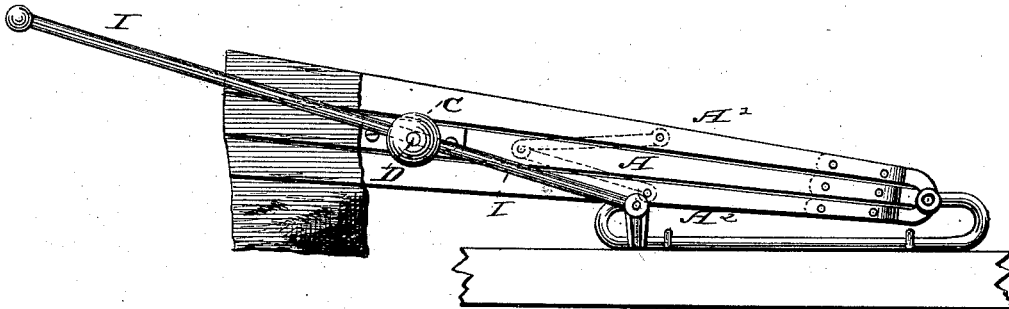
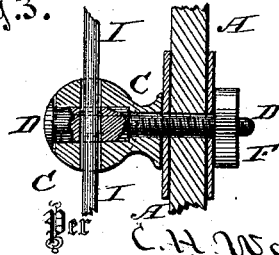

Fig. 3.



Witnesses:

*P. Dieterich*  
*Frank Duffy*

Inventors:

*Madore C. Hayes*  
*James H. Hayes*  
Attorneys.  
*C. H. Watson & Co.*

# UNITED STATES PATENT OFFICE.

THEODORE E. HAYES AND JAMES H. HAYES, OF SPRING GREEN, WIS.

## IMPROVEMENT IN VEHICLE-TOPS.

Specification forming part of Letters Patent No. 203,450, dated May 7, 1878; application filed March 1, 1878.

*To all whom it may concern:*

Be it known that we, THEODORE E. HAYES and JAMES H. HAYES, of Spring Green, in the county of Sauk and State of Wisconsin, have invented certain new and useful Improvements in Buggy-Tops; and we do hereby declare that the following is a full, clear, and exact description thereof, which will enable others skilled in the art to which they appertain to make and use the same, reference being had to the accompanying drawings, and to the letters of reference marked thereon, which form a part of this specification.

This invention relates to buggy-tops; and it consists in the construction of the devices for adjusting the buggy-top, as will be hereinafter more fully set forth.

In the annexed drawing, to which reference is made, and which fully illustrates this invention, Figure 1 is a side elevation showing the top open, and Fig. 2 is a side elevation showing the top closed. Fig. 3 is a section through the knob.

A, A<sup>1</sup>, and A<sup>2</sup> represent three bows for a buggy-top, hinged and arranged in any of the known and usual ways, and the front and rear bows A<sup>1</sup> A<sup>2</sup> are connected by the hinged braces B B.

The devices for adjusting the buggy-top consist of a knob or cylinder, C, having a hole through its center, and with a bolt, D, passing through the same. A section of one end of this bolt is large enough to fill the hole in the cylinder, while the smaller end has screw-

threads to receive a thumb-screw, F. Near the outer end of the knob or cylinder C is a hole made diametrically through it, and also through the bolt D. This hole is to receive a straight brace, I, which is hinged or pivoted at its lower end, as shown.

The base of the cylinder rests against the bow A, the small end of the bolt D passing through the bow at a point about two feet, more or less, up from the shifting-rail to the inside of the buggy-top, where it receives the thumb-screw F.

In tipping the top back and forward, the brace will pass through the diameter of the cylinder and bolt, and by tightening the thumb-screw F it draws the bolt in, clinching the brace, and fixing the top stationary at any angle.

Having thus fully described this invention, what is claimed, and desired to be secured by Letters Patent, is—

The combination, with an adjustable buggy-top, of the cylinder or knob C, bolt D, thumb-screw F, and hinged brace I, all constructed substantially as and for the purposes herein set forth.

In testimony that we claim the foregoing as our own we have hereto affixed our signatures in presence of two witnesses.

THEODORE E. HAYES.

JAMES H. HAYES.

Witnesses:

ENOS C. BRAINERD,  
CALVIN L. HAYES.