

F. LARSON & F. D. LIVERMORE.  
Sleigh-Knee.

No. 203,470.

Patented May 7, 1878.

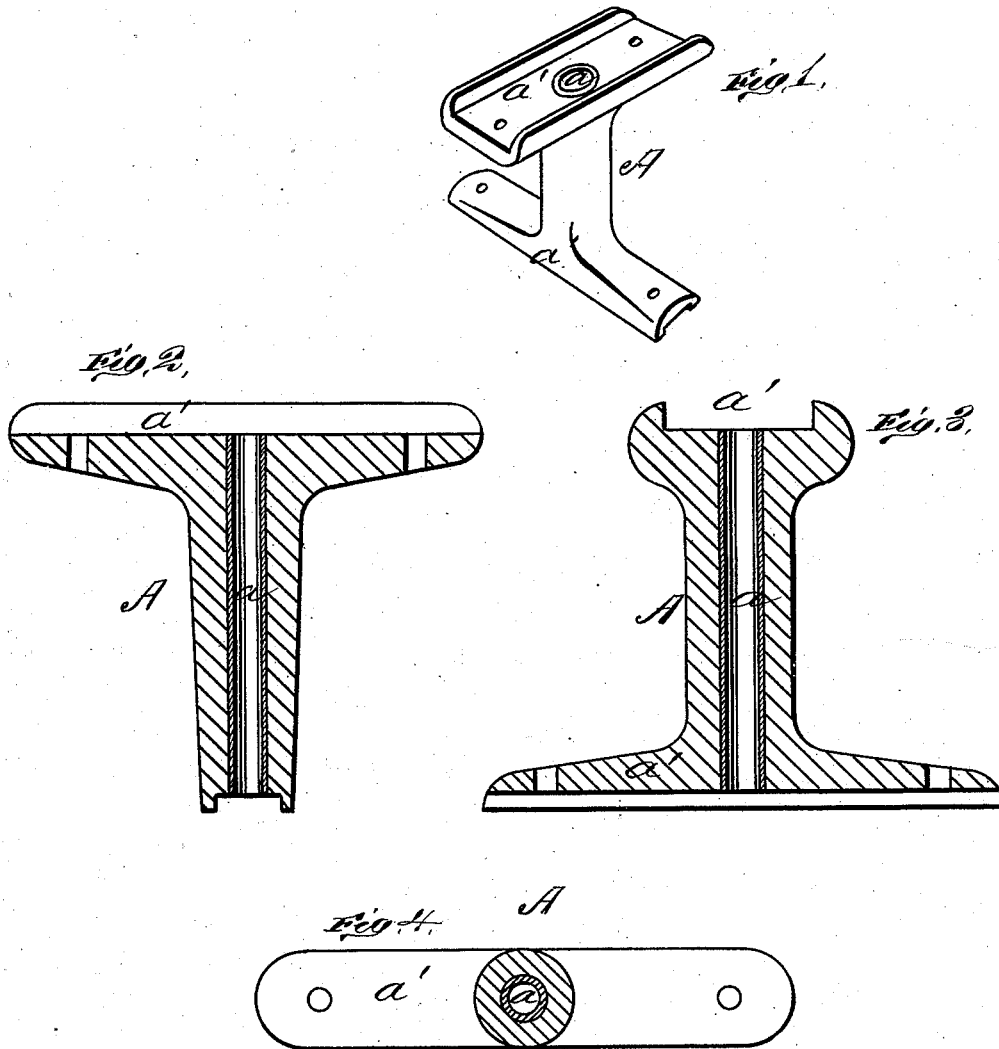

WITNESSES  
*E. A. Bates*  
*A. J. Masi*

INVENTORS  
*Frank Larson,*  
*F. D. Livermore,*  
*by E. M. Anderson,*  
ATTORNEY

# UNITED STATES PATENT OFFICE.

FRANK LARSON AND FREDERICK D. LIVERMORE, OF ROCHESTER, MINN.

## IMPROVEMENT IN SLEIGH-KNEES.

Specification forming part of Letters Patent No. **203,470**, dated May 7, 1878; application filed January 19, 1878.

*To all whom it may concern:*

Be it known that we, FRANK LARSON and FREDERICK D. LIVERMORE, of Rochester, in the county of Olmsted and State of Minnesota, have invented a new and valuable Improvement in Sleigh-Knees; and we do hereby declare that the following is a full, clear, and exact description of the construction and operation of the same, reference being had to the annexed drawings, making a part of this specification, and to the letters and figures of reference marked thereon.

Figure 1 of the drawings is a representation of a perspective view of our improved sleigh-knee. Figs. 2 and 3 are longitudinal sections thereof, and Fig. 4 is a cross-sectional view thereof.

This invention has relation to improvements in cast-metal sleigh-knees; and the nature of the invention consists in a cast-iron sleigh-knee, cast around a tubular wrought-iron core for the passage of a through-bolt, as will be hereinafter more fully shown and described.

In the annexed drawings, the letter A designates a cast-iron sleigh-knee, having a wrought-iron core, *a*. This core, being tubular, is placed in a mold, and the metal cast around it, thereby forming a strong and reliable knee.

The knee will have the bearings *a'* for the rave and runner, the said bearings being at right angles to the length of the knee and in planes at right angles to each other. The core *a* being tubular, as shown in the drawings, its bore will serve as a passage for the bolt which connects the rave and runner.

It is evident that the strength of the knee is greatly increased by this combination in its structure of cast and wrought iron, and that its strength is independent of the bolt passed through it, and that the knee itself may be cast lighter than hitherto required, so as to have a neater and more graceful appearance.

What I claim as new, and desire to secure by Letters Patent, is—

A cast-iron sleigh-knee having a tubular wrought-iron core for the passage of a through-bolt, substantially as specified.

In testimony that we claim the above we have hereunto subscribed our names in the presence of two witnesses.

FRANK LARSON.  
F. D. LIVERMORE.

Witnesses:

S. W. EATON,  
FRANK M. CORNELL.