

I. Q. SHERWOOD.
Step-Ladder.

No. 203,561.

Patented May 14, 1878.

Fig. 1.

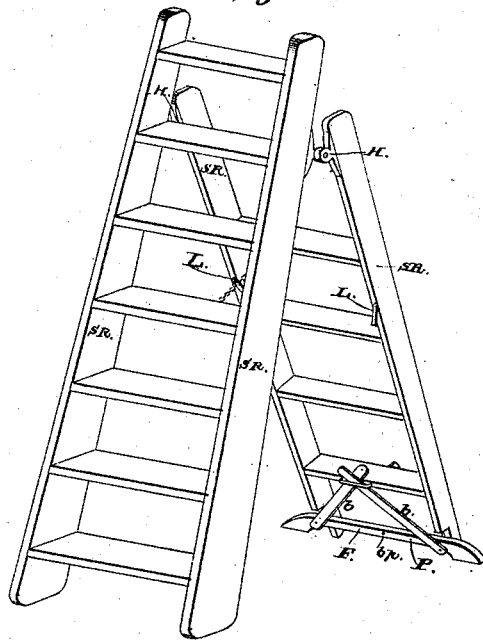

Fig. 2.

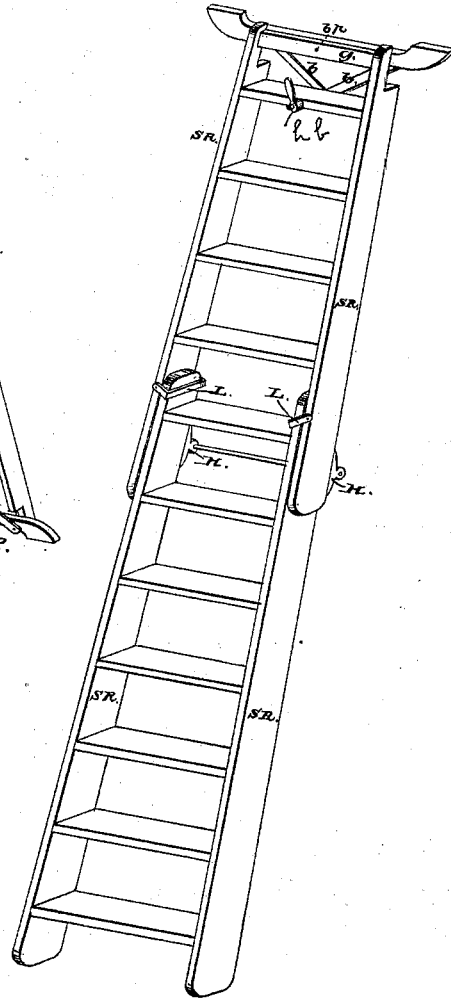

Fig. 3.

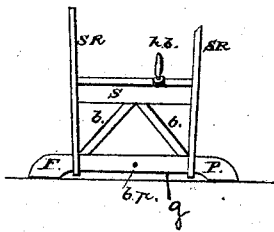

Fig. 4.

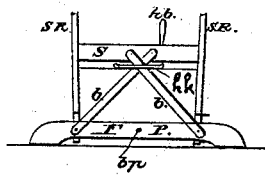
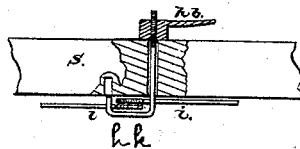

Fig. 5.



Attest:
H. M. Tuck
F. E. Palmer

Inventor:
I. Q. Sherwood

UNITED STATES PATENT OFFICE.

ISAAC Q. SHERWOOD, OF BAY CITY, MICHIGAN.

IMPROVEMENT IN STEP-LADDERS.

Specification forming part of Letters Patent No. 203,561, dated May 14, 1878; application filed September 24, 1877.

To all whom it may concern:

Be it known that I, I. Q. SHERWOOD, of Bay City, Michigan, have invented a Ladder, of which the following is a specification:

The object of my invention is to provide a ladder made in two sections, which may be extended and used as a long ladder, as shown in Figure 2 of accompanying drawing, or may be folded in the form of a step-ladder, the upper section forming the brace or support for the lower section, as shown in Fig. 1 of said drawing; also, a ladder having an attachment at the extreme end of the upper section, which rests on the ground when the ladder is folded, as in Fig. 1, by which it is made to conform to the shape of the ground, whether rough or smooth.

The ladder is illustrated in the perspective view, Fig. 2, as extended to form a long ladder. The lower ends of the side rails of upper section are placed outside of the upper ends of side rails of lower section, and held in place by the hinges marked H, which are placed on the back edges of the side rails of both the upper and lower section of the ladder; also, by loops of iron or other metal, which are fastened to side rails of upper section, falling over the ends of side rails of lower section, as shown in Fig. 2.

In Fig. 1, perspective view, the ladder is folded in form of a step-ladder, with the upper end of upper section turned downward and resting on the ground. The piece extending from one side rail to the other, and projecting outward each way, (marked F P,) is a foot-piece, which, together with the braces *b b*, hook *h k*, and hand-burr, (marked *h b*,) form the leveling attachment.

In Figs. 3, 4, and 5, the leveling attachment

is illustrated. Fig. 3 is a front view. S R are side rails. F P is foot-piece. *g* is girt, Figs. 2 and 3, extending from one side rail to the other, and to which the foot-piece is attached by means of the bolt or pin marked *b p*, and which allows the ends of the foot-piece to rise or fall, as may be required to suit the ground.

b b are braces, fastened at their lower ends to foot-piece, and by which the same is held in place where desired. S is a step, to which the braces *b b* are secured by means of hook *h k*. (Shown in Fig. 5.) *h b* is a hand-burr, by which the hook *h k* is drawn tightly against the braces *b b*, as may be seen in Fig. 5.

Fig. 4 is a back view of leveling attachment, showing foot-piece and braces attached to step by means of the hook *h k*. Fig. 5 shows braces *b b*, hook *h k*, and section of step.

I claim as my invention—

1. The two ladder-sections united by hinges H at what are the rear edges of the side rails when the ladder is extended, and at a distance from the end of one or both sections, whereby the ladder may be completely closed, and when the ladder is extended the sections shall be in the same line, and the lower end of the upper section shall inclose the upper end of the lower section in a manner to allow the free use of steps at the top end of said lower section, all substantially as described.

2. The foot-piece F P, with the braces *b b* fastened to a step or girt by the hook *h k* as a leveling attachment, substantially as described.

I. Q. SHERWOOD.

Witnesses:

G. M. TUCKER,
F. E. PALMER.