

F. SONDERMEYER.
Millstone-Pick.

No. 203,562.

Patented May 14, 1878.

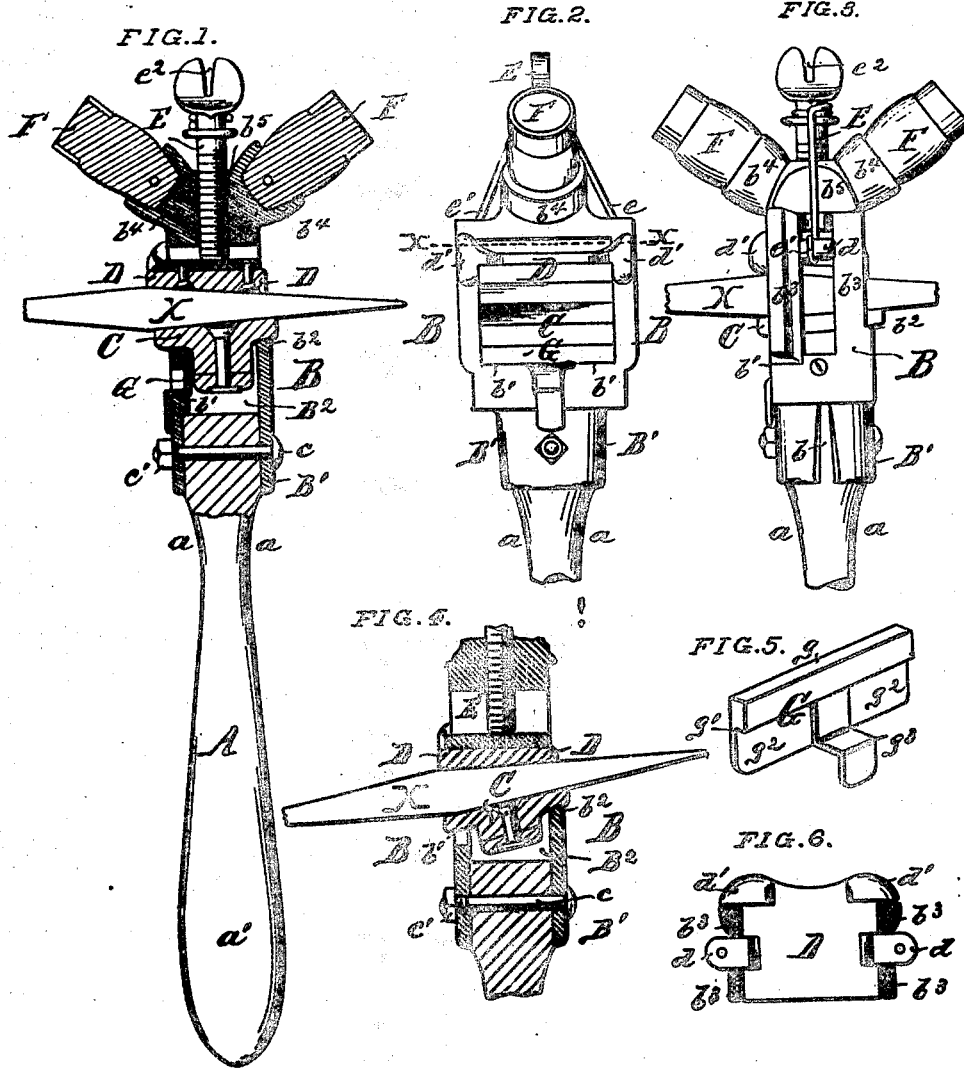

ATTEST:
J. W. Hertel,
Charles Hertel,

INVENTOR:
Frederek. Sondermeyer
per Ruthel & Co
Atty

F. SONDERMEYER.
Millstone-Pick.

No. 203,562.

Patented May 14, 1878.

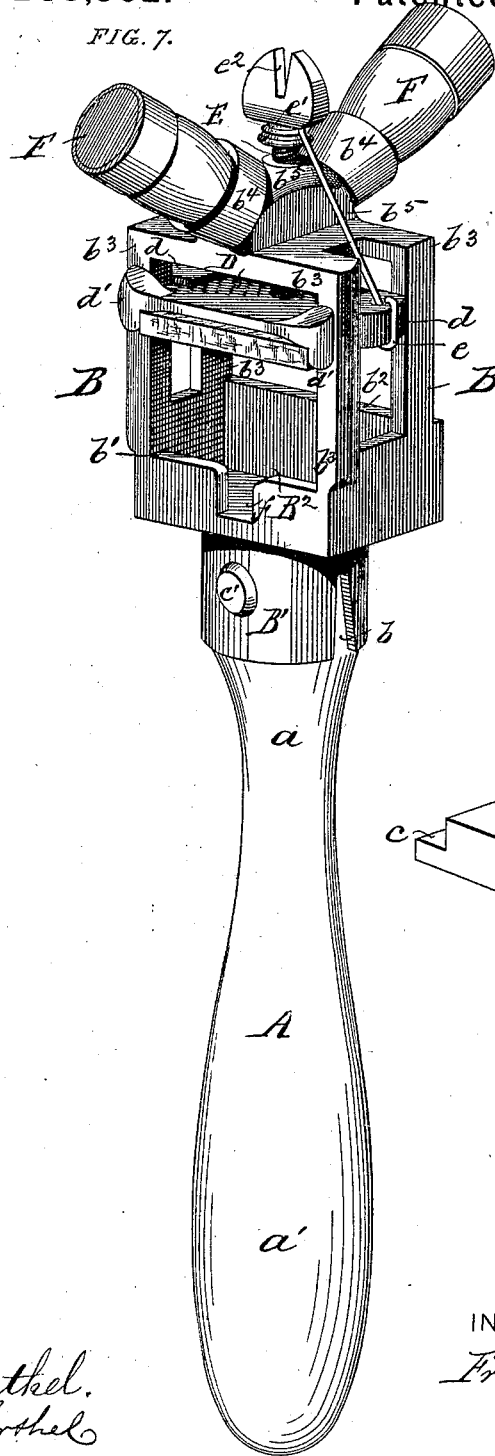

FIG. 7.

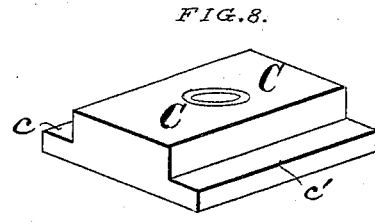

FIG. 8.

ATTEST:

J. W. Hertkel.
Johas Hertkel

INVENTOR:

Frederick Sondermeyer
per
Hertkel & Co
Attys

UNITED STATES PATENT OFFICE.

FREDEREK SONDERMEYER, OF MORRISEY, ILLINOIS.

IMPROVEMENT IN MILLSTONE-PICKS.

Specification forming part of Letters Patent No. **203,562**, dated May 14, 1878; application filed January 18, 1878.

To all whom it may concern:

Be it known that I, FREDEREK SONDERMEYER, of Morrisey, St. Clair county, and State of Illinois, have invented an Improved Millstone-Pick, of which the following is a specification:

This invention is an improved millstone-pick for furrowing, dressing, and trimming millstones.

The object of my invention is to dispense with the wedges and fastening devices ordinarily used to secure the bit, and to overcome the disadvantages arising from the use of the ordinary millers' tool of this class.

My invention consists in the improved means whereby the steel bit or pick proper can be more firmly secured in the various positions required, and also be more readily detached and adjusted, and otherwise be better adapted to perform the work for which the tool is designed.

Of the drawing, Figure 1 is a sectional elevation of my improved tool; Figs. 2 and 3, respective front and side elevations. Fig. 4 is a sectional elevation, showing the bit secured in a tapering position. Fig. 5 is a perspective view of an intermediate shoulder-plate. Fig. 6 is a top sectional plan on line X X of Fig. 2. Fig. 7 is a perspective view of the tool-holder, excepting the bit, the shoulder-plate, and rubber platen. Fig. 8 is a perspective view of the rubber platen.

A is the handle. This I prefer to make of the constructive shape shown in Figs. 1 and 7. The operator rests the tool at the point *a* upon the forefinger of his left hand, his right hand having grasped the handle at *a'*, and thus he is the better enabled to control, balance, and wield the tool. Further, the handle so fashioned—that is, to have the thinner part at *a* and the thicker part at *a'*—greatly aids the operator to impart a steady, decisive, and direct blow.

B represents my improved holder to contain the bit, and also the interior operating parts (as will hereinafter appear) to hold the bit securely. Said holder is further constructed with a view to enable the bit to be placed in various positions, and as is required to suit the nature of the work to be done. This

holder is cast, say, of malleable iron, and formed in its entirety to possess the following constructive features, more clearly shown in Fig. 7, and which are as follows: Projecting from the bottom of the holder is an annular socket, B¹, having side openings *b*, also shown in Figs. 1, 2, 3.

At B² the rectangular walls form a recessed seat or chamber, the upper faces of said walls constituting the front and rear shoulders *b*¹ *b*², the latter being on a higher level, as shown in Figs. 1, 3, 4, 7.

*b*³ *b*³ are the opposite upright walls, an open space existing between them, as shown in Figs. 2, 3, 6, 7. The top of the holder has the opposite annular sockets *b*⁴ *b*⁴, which project diagonally, and between them is the center bearing *b*⁵. (See Figs. 1, 3, 7.)

The interior space of the holder, between its walls and between the bottom and top thereof, is left free or open, to contain the operating parts, such as the shoulder-plate, the rubber platen, and the adjustable slide, as will hereinafter appear.

Having thus described the holder B as a casting, I will now proceed to give the purposes for which each part is so constructed and its relation to the operating parts.

In the socket B¹ the handle A is firmly secured by a screw-bolt, *c*, passing through the parts just named, the screw being held by a nut, *c'*. (See Figs. 1, 2, 3, 4, 7.) The openings *b* in the socket B¹ permit the same to be drawn or clamped together, and thus the more firmly secure the handle.

The seat B² is to retain a filling of rubber, leather, or the like material, forming the lower platen, upon which the bit is to be clamped.

The shoulders at *b*¹ *b*² form the needed bearing for the projecting ends of the leather platen used. The shoulder *b*², being higher than that of *b*¹, enables the leather platen to be seated and secured in the recess B², so that the top surface of said platen shall have an incline to suit the tapering position in which at times the bit is to be placed. (See Fig. 4)

The walls *b*³ *b*³ serve as braces and guides for the slide or clamp that operates within the open space of the holder, the lugs of said slide projecting between said walls. (See figures.)

The diagonal-positioned sockets b^4 at top are to contain the hammers, and through the center bearing b^5 the screw that operates the slide passes. (See Figs. 1, 2, 3, 4, 7.)

C represents the lower platen. It consists of several layers of, say, leather, riveted together to assume the shape shown in Fig 8, and so as to have the shoulders at $c c'$. The platen C so made is placed in its seat in the chamber B^2 , so that its shoulders $c c'$ shall bear upon the contiguous shoulders $b^1 b^2$ of the holder, (see Fig. 4,) or upon the shoulder b^2 , and the shoulder of the intermediate shoulder-plate, (see Figs. 1, 2,) and as will hereinafter more fully appear.

D represents the adjustable slide. It is a rectangular-shaped flat plate having the projecting side lugs $d d$. (See Figs. 2, 3, 6, 7.) The front face of the slide has also lugs $d^1 d^1$ bearing against the front face of the holder or its walls b^3 . (See Figs. 2, 3, 7.) To the under face of the slide there is properly attached a layer of leather or the like, which forms the upper bearing-face that holds fast the bit in conjunction with the lower platen C.

To operate the slide D within the holder B I have provided a set-screw, E, which passes through the top center b^5 and engages the top of said slide. (See Figs. 1, 2, 4.) By screwing down the set-screw the slide lowers, and can be made to clamp the bit, which is previously inserted between the slide and the lower platen C. To raise the slide or adjust it, I have connected the said slide to the set-screw by a wire fastening. One end, e , of the wire is fastened to one of the lugs of the slide; thence said wire is fastened to the screw between its two shoulders, and the other end of the wire, e' , similarly passed and united to the opposite lug of the slide. (See Figs. 2, 3, 7.) The turning of the screw will therefore raise the slide, since this latter is fastened to the screw by the wire.

The cut e^2 (see Figs. 1, 3, 7) shown in the screw is to enable the operator to operate said screw by using the edge of the bit.

F F are the hammer-heads wedged in or fastened in both diagonal sockets. These heads permit the tool to be struck on either of said heads, so that a single blow will loosen or fasten the bit between the holding parts. In order to insert the slide D in its operating position in the holder B, one of the lugs of said slide is brought in line with a front slot, f . (See Fig. 7.) This permits the slide to be introduced so as to assume a horizontal position, especially since the back of the holder is an opening.

So far as described, it will be noticed that, in case the leather platen C is placed in its seat and the bit X is inserted between said platen and the slide, the bit will then assume an inclined position, owing to the fact that the said lower platen rests or bears upon the shoulders $b^1 b^2$, which are unequal in height. (See Fig. 4.) In this tapering or incline position the bit or tool can be used, and thus suit the peculiar nature of the work.

To hold the bit in a vertical position in the holder, I have provided additional means to cause the one shoulder of the holder B to be as near on a level with its opposite shoulder as possible; hence the intermediate shoulder-plate G of the constructive shape shown more clearly in Fig. 5. The shoulder-plate G has the shoulder at g , the bearing-edge at g^1 , the face g^2 , and the lip g^3 . (See Fig. 5.) The top face of the shoulder g makes the level bearing with the shoulder d^2 , the bearing g^1 supports the plate G upon the shoulder d^1 , and the lip g^3 engages the slot f , all indicated in Figs. 1 and 2. The shoulder-plate G being inserted in its place, (see Figs. 1, 2, 3,) the lower platen C is next inserted, so that its shoulders shall rest on top of the shoulder-plate, and also the opposite shoulder d^2 of the holder. The pick or bit is next inserted, (the slide having been adjusted,) and in this wise the bit can be secured, as shown in Figs. 1, 2, 3.

By means of the heads F F, after the bit has been inserted between the slide and lower platen, (either in the vertical or incline position,) in order to fasten the said bit, a single blow upon one of the heads is sufficient to more adequately wedge the bit. Therefore the operator, with the tool in hand and causing one of the heads thereof to strike a blow upon the stone, insures a more complete wedging of the bit in the holder, and likewise the operator can readily disengage the bit by a single blow caused by striking the tool upon the opposite or other head.

The diagonal position of the heads permits the tool to be struck upon either of said heads without causing the bit to touch the stone in the act of loosening or fastening said bit, and without discomfort to operator, necessitating a change of position on his part. The bit can be secured so firmly that self-disengagement is impossible. It can be further adjusted and secured from time to time in accordance with its wear, and otherwise the bit can be used a longer time.

What I claim as my invention is—

1. The holder consisting of the socket B^1 , the recessed seat B^2 , the walls b^3 , the shoulders $b^1 b^2$, the diagonal sockets b^4 , and screw-bearing b^5 , as and for the purpose set forth.

2. The heads F F, in combination with a tool-holder, B, having the sockets b^4 , as and for the purposes set forth.

3. The lower platen C, having shoulders $c c'$, as and for the purpose set forth.

4. The intermedial shoulder-plate G, as and for the purposes set forth.

5. The shoulder-plate G, having the shoulder g , the bearing g^1 , and lip g^3 , in combination with the seat B^2 of a holder, B, as and for the purposes set forth.

6. The combination of the lower platen C, the shoulder-plate G, and holder B, having the recessed seat B^2 .

7. The combination of the lower platen C with the holder B, having recessed seat B^2 .

8. The holder B, provided with the annular

socket B¹, having openings *b*, as and for the purpose set forth.

9. The holder B, provided with the slot or opening *f*, as and for the purpose set forth.

10. The combination of the holder B, the lower platen C, the adjustable slide D, the screw E, the wire fastening, and intermediate shoulder-plate G, all said parts being con-

structed to operate in the manner and for the purpose set forth.

In testimony of said invention I have hereunto set my hand.

FREDEREK SONDERMEYER.

Witnesses:

JOHN W. HERTHEL,
WILLIAM W. HERTHEL.