

M. BUDGE.  
Dumping-Wagon.

No. 203,588.

Patented May 14, 1878.

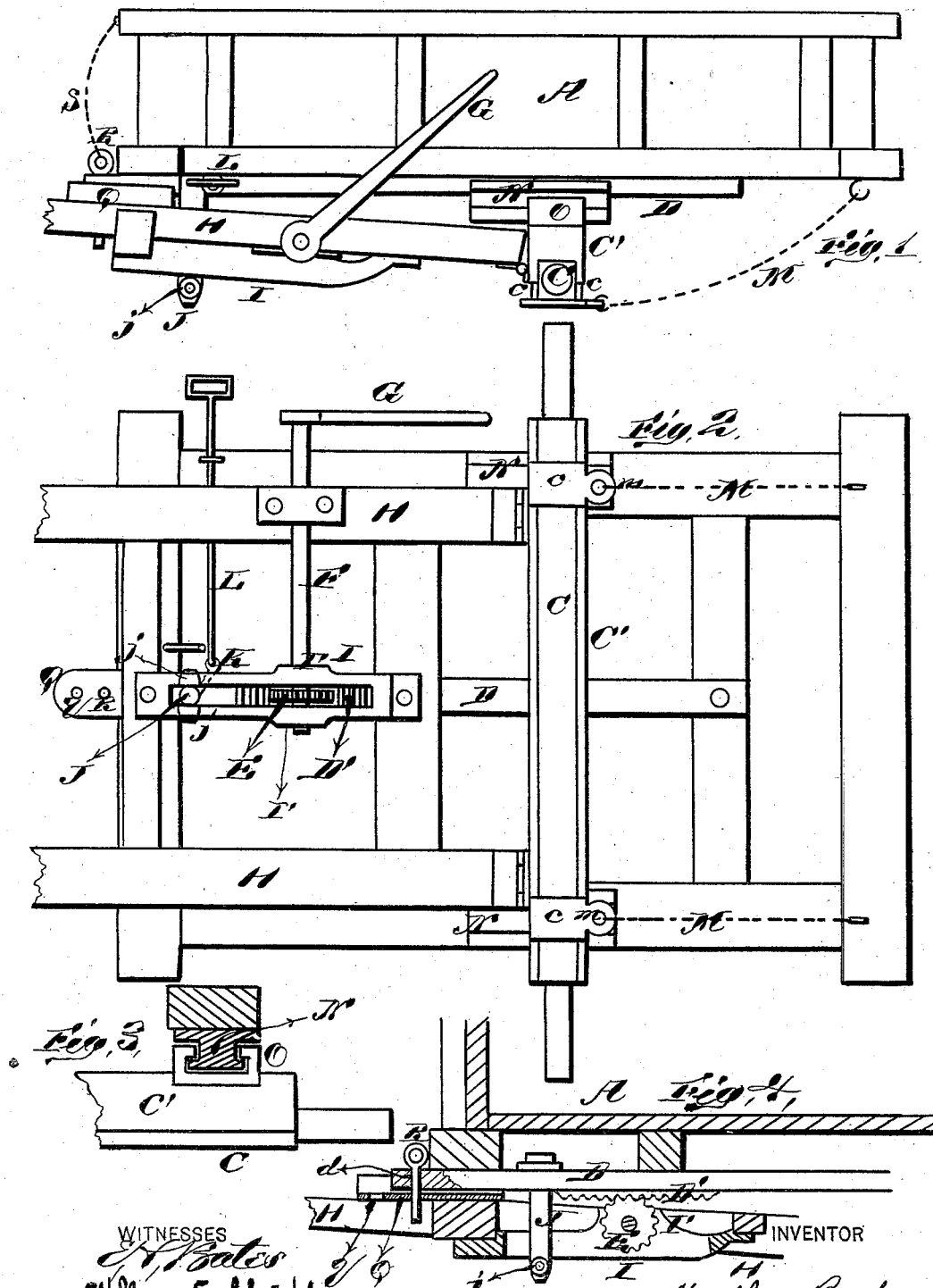

WITNESSES  
*W. Pates*  
William E. Schiller

INVENTOR  
Matthew Budge  
W. H. Babcock.  
ATTORNEY.

# UNITED STATES PATENT OFFICE.

MATTHEW BUDGE, OF MIDDLEBURY, CONNECTICUT.

## IMPROVEMENT IN DUMPING-WAGONS.

Specification forming part of Letters Patent No. 203,588, dated May 14, 1878; application filed March 23, 1878.

*To all whom it may concern:*

Be it known that I, MATTHEW BUDGE, of Middlebury, in the county of New Haven and State of Connecticut, have invented certain new and useful Improvements in Movable Cart-Bodies; and I do hereby declare that the following is a full, clear, and exact description thereof, which will enable others skilled in the art to which it appertains to make and use the same, reference being had to the accompanying drawings, and to letters of reference marked thereon, which form a part of this specification.

In said drawings, Figure 1 represents a side elevation of a cart or wagon embodying my invention. Fig. 2 represents a bottom view of the same. Figs. 3 and 4 are detail views.

This invention relates to that class of dumping-wagons which have a rack and pinion attachment for moving the wagon-body longitudinally; and it consists in certain improvements in the locking devices, guideways, and other parts of the wagon, hereinafter fully set forth.

In the accompanying drawings, A designates the body of my dumping cart or wagon, C being the axle thereof. On the bottom of said body, at the middle line thereof, is fastened a longitudinal plate, D, to the bottom of which, under the forward part of said body A, is fixed a longitudinal rack, D'.

E designates a pinion, which is arranged so as to engage with said rack when the said body A is in its normal horizontal position, and turns with a shaft, F, operated by a hand-lever, G. Said shaft is journaled in a frame, H, partly formed by the rear ends of the thills, which are hinged at their rear ends to a bolster, C', secured by clips *cc* to axle C. Frame H is provided with a longitudinal slotted bar, I, having enlargements or boxes I' I', between which boxes pinion E turns. These boxes also make a secure bearing for shaft F. The said frame H and thills are ordinarily attached to body A by means of a vertical rotary pin or bolt, J, which extends down through said plate D and said slotted bar I. Said stud is headed to prevent it from slipping entirely through said plate, with cross-studs, on which turn rollers *jj* on opposite sides. Bolt J is

also provided with an arm, K, which is operated by a rod, L, that extends through a suitable guide or guides to the side of the cart. When said rod is drawn upon, the said pin or bolt J is turned so as to bring the axial line of said rollers *jj* across the slotted bar I. As the said rollers extend in each direction beyond the slot in said bar, the effect is to lock said body A to said frame H. This is the normal state and position of said parts. Rack D' and pinion E are thus locked together, so that the rotation of the latter will cause the cart-body A to move backward or forward. By thus moving said body backward its center of gravity is shifted beyond axle C, so that it will dump automatically as soon as the said frame and body are disconnected, as above described.

To prevent any accidental rotation of said pinion, and consequent shifting of said body, or any shifting from the natural backward jolting incident to travel, I employ the following devices: Plate D is extended beyond the front end of said cart-body, and perforated at *d*, said perforation being arranged to register with a series, *q*, of similar ones in a channeled guide-plate, Q, attached to frame H. By means of a pin, R, which is adapted to pass through said holes *p q*, said body A may be locked at any position of longitudinal adjustment. Said pin is hung to said body by a chain, S. Said body is guided while moving, and braced as well, by longitudinal rails N and guideways O, correspondingly recessed and flanged, and secured, respectively, to the bottom of body A and the top of bolster C'. These devices also prevent said body from separating from said bolster. Plate D slides on a block secured to the top of said bolster. To prevent body A from moving backward too far, chains M M extend from the rear end of the same to rearward prolongations *m m* of clips *cc*.

For dumping, the pin R is first removed; the hand-lever G is then operated so as to move body A backward into the position desired, the tail-board or end-gate is then removed, and the bolt J is turned so as to disconnect said body from frame H. Gravity will then cause said cart-body to tip and discharge its

load in the usual manner. The rollers *jj* enable the said body to be moved backward and forward with very little friction.

Of course, various changes may be made without departing from the spirit of my invention. For instance, the rack may be attached to the hinged frame, and the pinion may be journaled to the cart-body. The fastening bolt or pin may also be rotated by ropes passing to opposite sides of the cart, instead of by the operating-rod described.

Having thus described my invention, what I claim as new, and desire to secure by Letters Patent, is—

1. The combination of bar I with the thills and body of a dumping-cart, rotating bolt J, and operating-rod L.
2. The combination of slotted bar I with bolt J, having anti-friction rollers *j*, and with the body and thills of a dumping-wagon.
3. A wagon provided with a longitudinally-

movable body, in combination with locking devices, substantially as described, whereby said body can be locked in more than one position of said longitudinal adjustment.

4. A dumping-wagon provided with a slotted bar, which serves both as a bearing and guard for the operating gear-wheel, and to engage with the locking-bolt which holds the body and thills together.

5. The combination, with the body and thills of a dumping-wagon, of flanged rail N and flanged guideway O, whereby the body is held to the bolster, substantially as set forth.

In testimony that I claim the foregoing as my own I affix my signature in presence of two witnesses.

MATTHEW BUDGE.

Witnesses:

JOSEPH B. SHEPHERD,  
ELWYN N. BRADLEY.