

I. H. CONGDON.
 Locomotive Smoke-Stack.

No. 203,592.

Patented May 14, 1878.

Fig. 3

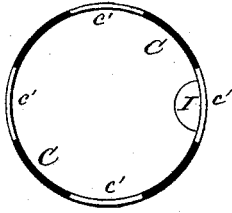

Fig. 2

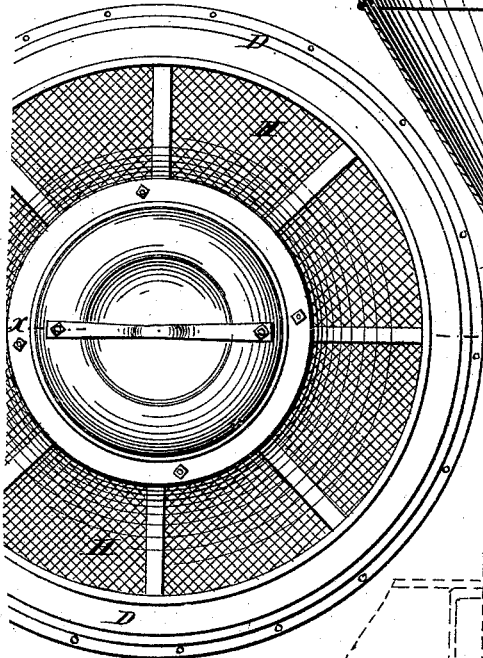
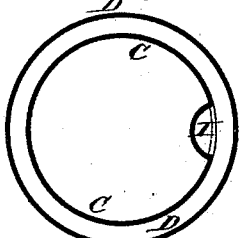

Fig. 4



WITNESSES:

C. Neveu
C. Sedgwick

Fig. 1

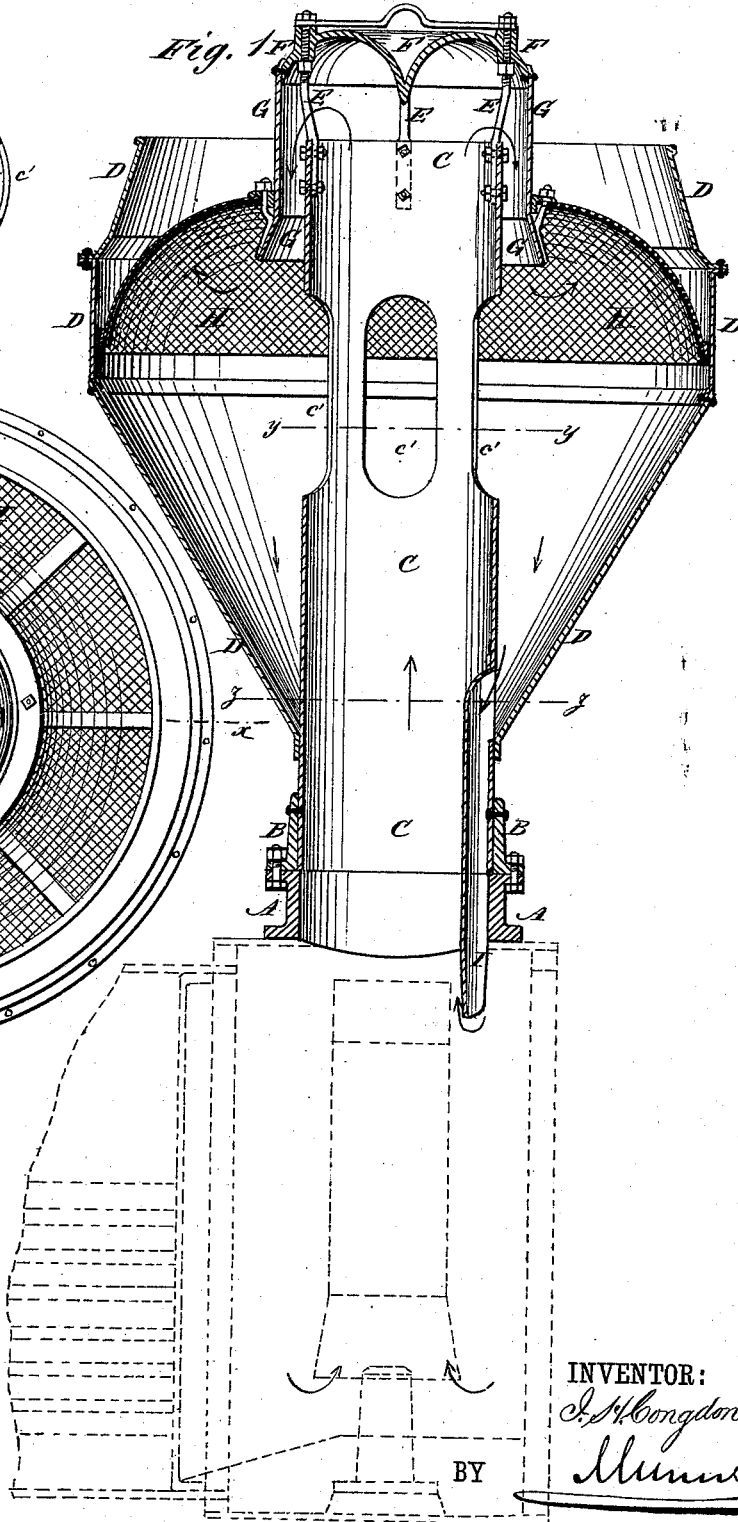

INVENTOR:

I. H. Congdon
Mumford

BY

ATTORNEYS.

UNITED STATES PATENT OFFICE.

ISAAC H. CONGDON, OF OMAHA, NEBRASKA.

IMPROVEMENT IN LOCOMOTIVE SMOKE-STACKS.

Specification forming part of Letters Patent No. 203,592, dated May 14, 1878; application filed February 25, 1878.

To all whom it may concern:

Be it known that I, ISAAC H. CONGDON, of Omaha, in the county of Douglas and State of Nebraska, have invented a new and useful Improvement in Locomotive Smoke-Stacks, of which the following is a specification:

Figure 1 is a vertical section of my improved smoke-stack, taken through the line *a a*, Fig. 2. Fig. 2 is a top view of the same. Fig. 3 is a horizontal section of the stack-body, taken through the line *y y*, Fig. 1. Fig. 4 is a horizontal section of the stack-body and shell, taken through the line *z z*, Fig. 1.

Similar letters of reference indicate corresponding parts.

The object of this invention is to furnish locomotive smoke-stacks which shall be so constructed that they will not choke the draft, and at the same time will arrest the sparks and prevent any danger from fire, and which shall be simple in construction, may be applied to any smoke-box, and will be very economical in use.

A represents the saddle, which is attached to the smoke-box of the boiler, and to which is bolted a cast-iron ring, B. To the ring B is riveted the lower end of the stack-body C. To the stack-body C, a little above the ring B, is secured the lower end of the shell D, the lower part of which is made in the form of an inverted cone. The upper part of the shell D is made in the form of an upright band, surmounted by a tapering band.

The upper ends of the stack-body C and the shell D are about upon a level, and to the upper end of the said stack-body C are attached the lower ends of a number of bolts, E, the upper ends of which are attached to the cone F, so as to support the said cone above the upper ends of the stack-body C and the shell D.

The edge of the cone F is curved downward, and to it is attached the upper edge of the return-cylinder G, which projects downward around the upper part of the stack-body C, and its lower part is flared outward or made bell-shaped. The upper part of the stack-body C thus serves as a circulating-plate to separate the upward and return currents.

The return-cylinder G passes down through

a hole in the center of the wire-gauze or netting H, which is secured to it and to the shell D by a frame-work or spider.

In the sides of the stack-body C, a little below the lower end of the return-cylinder G, are formed a number of oblong holes, *c'*, to prevent the draft from choking.

In the lower part of the stack-body C is formed a spark and cinder pipe, I, the upper end of which opens into the lower part of the space between the said stack-body C and the shell D, and its lower end projects downward below the saddle A, so as to enter the smoke-box and be below the upper end of the petticoat-pipe.

With this construction the sparks and cinders are carried up with and by the smoke and exhaust-steam through the stack-body C, strike against the cone F, and pass down through the space between the upper part of the said stack-body C and the return-cylinder G into the space between the stack-body C and the shell D, whence the light, fine, dead sparks pass out through the netting H. The large and heavy sparks and cinders drop through the space between the stack-body C and the shell D into the lower part of the said space, and pass through the pipe I into the smoke-box, where they come into the influence of the draft, and are again carried up through the stack-body C, and so on until they are beaten to powder and are carried out through the netting H.

By this construction, and the bell-shaped lower end of the return-cylinder G, the draft is softened, so that it will not cut the netting, and at the same time the draft will be so little obstructed or choked that the boiler will make steam to its full capacity.

My return-cylinder, with bell-shaped mouth at bottom, makes a large circumference at bottom, where the whole exhaust is distributed, the netting being thus made to last as long as any other part of stack.

My spark and cinder pipe has no holes through the stack-saddle, but a half-round sleeve fastened on the inside of stack-body, that runs only up to the body of the relief-openings. The remainder of pipe, with the relief-openings inside, merely operates as a circu-

lating-plate to separate the up and down currents, which make the stack work successfully.

What I claim as new, and constituting my invention, is—

1. The combination of the body C, provided with holes c' , cone D, pipe I, ring B, and saddle A, all constructed and arranged as shown and described.

2. The combination, with shell D and netting H, of the body C, having openings c' , the cone F, connected therewith by bolts E, and the return-cylinder G, all constructed and arranged as and for the purpose specified.

ISAAC HOPKINS CONGDON.

Witnesses:

LEWIS S. REED,
HARRY D. REED.