

G. D. EDMANDS.  
Spinning-Ring Holder, &c.

No. 203,606.

Patented May 14, 1878.

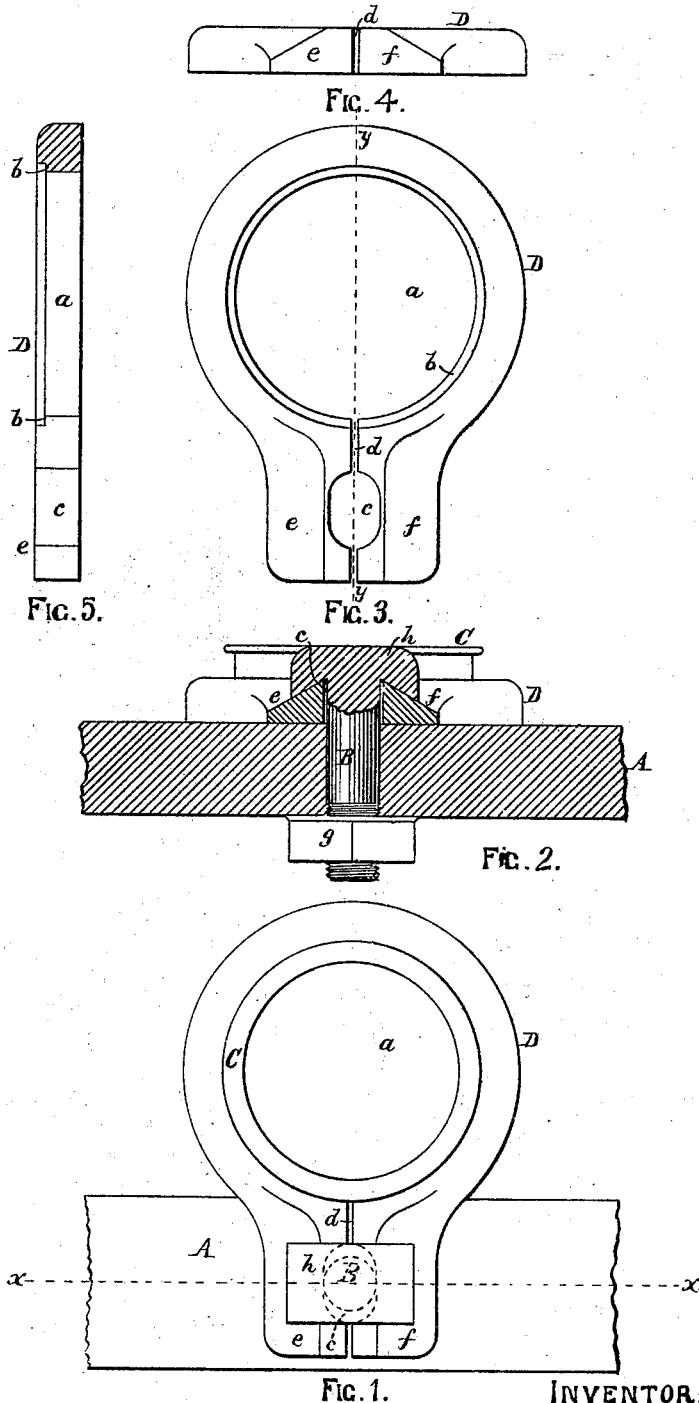

WITNESSES.

*E. A. Kemmenway*  
*G. E. Whitney*

INVENTOR.

*George D. Edmands*  
BY *N. P. Lombard,*  
ATTORNEY.

# UNITED STATES PATENT OFFICE.

GEORGE D. EDMANDS, OF MILFORD, MASSACHUSETTS.

## IMPROVEMENT IN SPINNING-RING HOLDERS, &c.

Specification forming part of Letters Patent No. **203,606**, dated May 14, 1878; application filed April 6, 1878.

*To all whom it may concern:*

Be it known that I, GEORGE D. EDMANDS, of Milford, in the county of Worcester and State of Massachusetts, have invented certain new and useful Improvements in Spinning-Ring Holders, and in the manner of attaching them to their rails, of which the following, taken in connection with the accompanying drawings, is a specification.

My invention relates to the construction of ring-holders and the method of attaching them to the ring-rails of spinning-frames; and it consists in the use of a ring-holder provided with a circular opening and suitable seat to receive the ring, and having an exterior projection upon one side, through the center of which is cut a narrow slit, to render said holder capable of being sprung, so as to slightly reduce the interior diameter thereof and cause it to gripe the ring and hold it firmly therein, and also provided with a slotted bolt-hole, forming an enlargement of said slit, to receive a clamping-bolt for securing said holder to the rail, and having the outer portions of the upper side of the extension contiguous to said bolt-hole and slit made inclined in opposite directions, as will be more fully described.

My invention further consists in the use, in combination with a ring-holder constructed as above described, of a clamping-bolt provided with a suitable thread and nut at one end and an oblong head at the other end, the under or bearing side of which is undercut upon two opposite sides, or inclined downward from the body of the bolt to the outer end or edge of the head, in such a manner that when placed in position to secure the holder in place on the ring-rail said inclined under surfaces of the bolt-head shall rest upon and fit the inclined upper surfaces on the holder, and, as said bolt is drawn downward to bind the holder to the rail, by screwing up the nut upon its lower end said inclined surfaces shall act to draw the two parts of the holder toward each other, tending to close the slit and cause the holder to gripe the ring and hold it firmly therein.

Figure 1 is a plan of my improved holder applied to a ring-rail and holding the ring. Fig. 2 is a vertical longitudinal section on line *x x* on Fig. 1. Fig. 3 is a plan of the holder

detached. Fig. 4 is a front elevation, and Fig. 5 is a vertical section on line *y y* on Fig. 3.

A is the ring-rail; B, the clamping-bolt; C, the ring, and D the ring-holder.

The ring C may be of any ordinary construction. The ring-holder D consists of a metal plate having the circular hole *a* cut through it, the upper portion of which is counterbored to form the ledge or rest *b*, upon which rests the lower side of the ring C when placed in position.

The exterior outline of the holder is substantially as shown in Fig. 3, being cut on a line concentric with the periphery of the hole *a* for about three-fourths of its circumference, while the other fourth is extended to form a foot or bearing to rest upon the rail, as shown in Fig. 1. Through the center of this extension is made a slotted or oblong bolt-hole, *c*; and extending from opposite sides thereof radial to the hole *a* is cut the slit *d*, dividing the enlarged side of the holder into two prongs, *e* and *f*, the outer portions of the upper sides of which are beveled or inclined in opposite directions, as shown in Figs. 2 and 4. The bolt B has cut upon one end a screw-thread, to which it fitted a nut, *g*, and has formed upon its other end an oblong head, *h*, the under sides of the two opposite portions of which are inclined in opposite directions, corresponding to the bevels on the holder, before described.

The operation of my improved holder is as follows: The ring C is placed in position in the holder, resting upon the ledge *b*, said ring filling tightly the counterbore. The holder is then placed in position on the rail, and the bolt B is passed through the slotted hole *c* and through the hole in the rail A, and the nut *g* is placed on said bolt and turned up against the under side of the rail, drawing the bolt downward, with the inclined surfaces of the under side of its head resting upon the inclined upper surfaces of the prongs *e* and *f* of the holder, thereby drawing said prongs toward each other, and causing the holder to gripe the ring and hold it firmly in position therein, and at the same time clamping the holder firmly upon the rail in any desired position.

By this improvement the ring is rendered easily adjustable to the desired position, as the holder may be turned about the clamping-bolt B, or be moved in a direction radial to the axis of the ring a limited distance, thereby giving all needed adjustment by the simple slacking and tightening of a single nut.

What I claim as new, and desire to secure by Letters Patent of the United States, is—

1. The ring-holder D, provided with a circular seat or rest for the ring, the prongs *e* and *f*, having their upper surfaces inclined in opposite directions, the slotted bolt-hole *c*, and the dividing or separating slit *d*, all arranged relative to each other, substantially as described.

2. The holder D, divided on one side by the slit *d*, and provided with a slotted bolt-hole, *c*, and beveled prongs *e* and *f*, in combination

with the ring-rail A and the bolt B, provided with the nut *g* and hook-shaped head *h*, all arranged and adapted to operate substantially as and for the purposes described.

3. A ring-holder cut open upon one side and adapted to be sprung to gripe the ring, and provided with one or more inclined or beveled surfaces, in combination with a single clamping-bolt adapted to clamp said holder to the rail, and at the same time, by acting upon said inclined surfaces, cause the holder to gripe the ring and hold it firmly in position, substantially as described.

Executed at Milford, Massachusetts, this 2d day of April, A. D. 1878.

GEORGE D. EDMANDS.

Witnesses:

F. J. DUTCHER,  
E. D. BANCROFT.