

J. T. POLK & O. H. CASTLE.
Green-Corn Cutter.

No. 203,642.

Patented May 14, 1878.

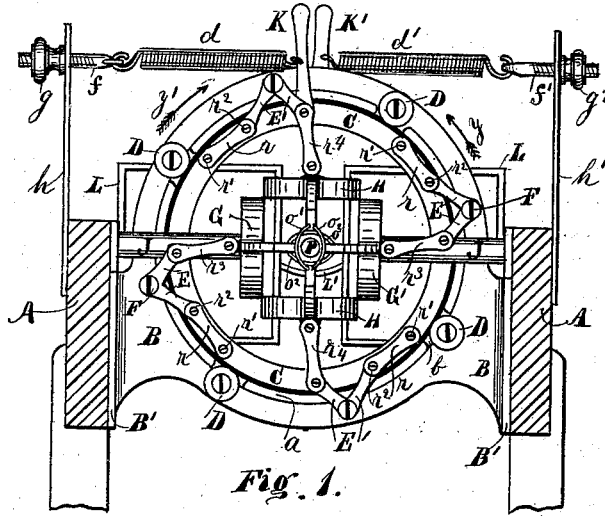

Fig. 1.

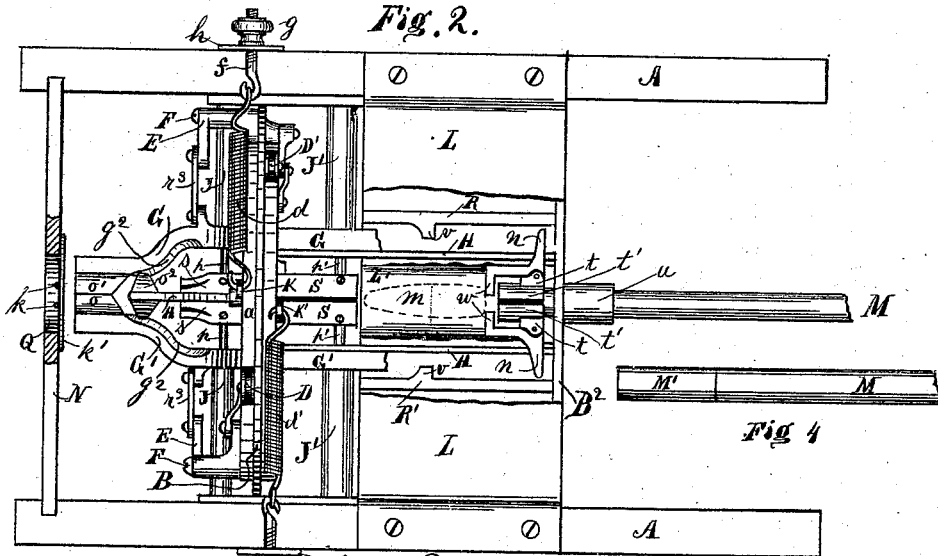

Fig. 2.

Fig. 4.

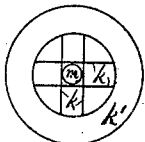

Fig. 5.

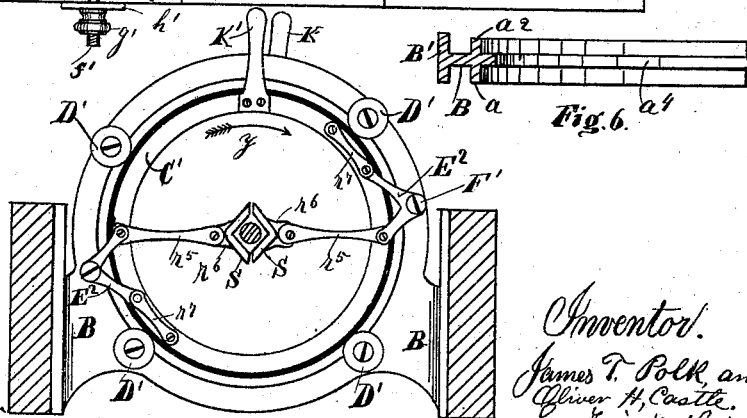

Fig. 3.

Fig. 6.

Witnesses;
C. J. Backlund,
J. E. Woolverton.

Inventor.
James T. Polk and
Oliver H. Castle,
By C. J. Backlund, their
Attorney

UNITED STATES PATENT OFFICE.

JAMES T. POLK, OF GREENWOOD, AND OLIVER H. CASTLE, OF INDIANAPOLIS,
INDIANA; SAID CASTLE ASSIGNOR TO SAID POLK.

IMPROVEMENT IN GREEN-CORN CUTTERS.

Specification forming part of Letters Patent No. 203,642, dated May 14, 1878; application filed
March 2, 1878.

To all whom it may concern:

Be it known that we, JAMES T. POLK, of Greenwood, in the county of Johnson, and OLIVER H. CASTLE, of Indianapolis, in the county of Marion and State of Indiana, have invented a new and useful Improvement in Green-Corn Cutters, of which the following is a specification, reference being had to the accompanying drawings.

Our invention relates to an improved machine designed for cutting green corn from the cob.

The object of our invention is to remove the kernels of green corn from the cob and the juice and chit preparatory to canning the same.

Our invention consists of the new construction and arrangement of parts, and in the new combination of old elements, all of which, singly or combined, are deemed essential in our newly-organized green-corn cutters, and which will be hereinafter described and set forth.

We are aware of Letters Patent granted to B. Merrit, February, 1874, and to V. Barker, February, 1875, in which there may be some outward resemblance to our invention; but in the details of construction and mode of operation our present invention is radically different in all respects.

In the accompanying drawings, in which like letters of reference in the different figures indicate like parts, Figure 1 is a front-end elevation of our improved green-corn cutter with the cob-scraping device removed. Fig. 2 is a top or plan view of the same with the cob-scraping device partially in section. Fig. 3 is a partial rear-end elevation of the same. Fig. 4 represents a short section of the piston. Fig. 5 represents a front view of the cob-scraping device. Fig. 6 is a horizontal section of the front metallic frame.

A A represent the side frames, united together by the front and rear metallic frames B B², by means of the flanges B¹ B¹, and suitable bolts or screws. The front metallic frame is formed with the web B and side flanges B¹ B¹, and has a round opening in its center, with annular rims a a² at each side, and a central flange, a⁴, as shown in the horizontal section in Fig. 6. Inside of the annular rim a, at the

front of the metallic frame B, operates an annular ring, C. This ring is held in position by the inner flange a⁴ and the grooved rollers D D D, said rollers revolving on studs secured to the frame B, and the ring C is permitted to partially revolve on said rollers. To the front of the frame B the bell-crank levers E E E¹ E¹ are attached by pivot-studs F F F, on which they operate loosely. To one end of each of these levers is pivoted one end of the links r r r r, and the other end of said links is pivoted to the annular ring C, in the manner shown in Fig. 1. The other ends of the upper and lower bell-crank levers E¹ E¹ are also pivoted to one end of the links r⁴ r⁴, and the other end of said links is pivoted to the upper and lower cutter-frames H H. The corn-cutter frames G G' are also connected to the crank-levers E E by the links r³ r³ in the same manner. Each of said corn-cutter frames is pivoted at its rear end to the metallic frame B², so as to permit the front ends of the frames to open or close and prevent lateral motion. A lever, K, is also attached to said ring C, with a spring, d, connected with it, and an adjustable screw-hook, f, which is supported in a standard, h, and operated by a nut, g.

It will be seen from the foregoing that when the lever K is moved in the direction of the arrow y' the ring C is partially rotated in the grooves of the rollers D D D D, and the links r r r r cause the bell-crank levers E E E¹ E¹ to partially rotate on their studs, and the links r³ r³ at the sides draw the cutter-frames G G' and cutters away from the center horizontally. At the same time the links r⁴ r⁴ cause the top and bottom cutter-frames H H and their cutters to move away from the center vertically, and the same result is produced on all the cutters and frames when an ear of corn is forced through the cutters. The lever K in this case operates, in connection with the spring d, to hold the cutters in close contact with the corn-cob.

The horizontal cutter-frames G G' are of the form shown in Fig. 2. The curved front ends are provided with curved V-shaped cutters o o', which may be adjustable. The other cutter-frames, H H, are also provided with cut-

ters $o^2 o^2$ in the same manner, which are immediately in the rear of the cutters $o o^1$. All of said cutters operate from a common center line, and all operate together by being simultaneously forced apart as the cob is pushed through. The cutter-frames $G G' H H$ are curved at their union with the cutters $o o^1 o^2 o^2$, and their inner curved edges are formed with knife-edges $g^2 g^2$, so as to cut slightly into the cob, and thus regulate the depth of the cut of the cutters $o o^1 o^2 o^2$.

At the rear side of the front metallic plate on frame B, and operating in rollers $D' D' D' D'$, is another annular ring, C' . (Shown in Fig. 3.) This ring has two links, $r^7 r^7$, pivoted to it and to one arm of the bell-crank levers $E^2 E^2$. Said levers are also pivoted to the frame B by studs F' . To the other arms of said levers are pivoted one end of the links $r^5 r^5$. The other end of said links are pivoted to the corn-guides $S S$. The corn-guides are supported by guide-rods $p p p' p'$, which operate in the horizontal sockets or sleeves $J J J' J'$, and have flexible guides $s s$ at the extreme front end, to steady and guide the corn while passing into the cutters $o o^1 o^2 o^2$. To the annular ring C' is also attached a lever, K' , operated by a spring, d' , attached to a screw-hook, f' , that is supported in the standard h' and provided with an adjusting-nut, g^1 .

It will be seen from the foregoing that when the lever K' is moved in the direction of the arrow y , Fig. 3, that the links $r^7 r^7$ operate the bell-crank levers $E^2 E^2$, and the links $r^5 r^5$ draw the guides $S S$ apart horizontally, and the same result is produced when an ear of corn is introduced between the said guides. The object of the levers $K K'$ is to permit the cutters to be opened, also the guides, whenever it may become necessary to remove an ear of corn, or to clean the guides from husks or other matter.

The table $L L$ is secured to the side frames $A A$, as shown in Figs. 1 and 2, and extends to near the center of the machine horizontally. It then descends and forms the hopper L' , the curved bottom of which is just below the common center of the cutter-frames and corn-guides, and forms a support for the corn m to rest on in front of the plunger M .

The movable head $t' t'$ is a piece of sheet-steel, bent in a circular form, so as to form a spring-clamp around the piston $M M'$, producing friction on said piston sufficient to cause the head $t' t'$ to move to and from the guides S as the piston moves.

The spring-clamp $t' t'$ is provided with hinges $t t$ at each side, in which are pivoted the hook-levers $w n$, as shown in Fig. 2.

The piston M is provided with a wooden end or plug, M' , to prevent injury to the cutters $o o^1 o^2 o^2$ as the piston pushes the corn through them. Said piston operates in a suitable guide, u , formed or attached to the rear frame B^1 .

The piston enters the spring-clamp $t' t'$, and as the said head or clamp moves forward the ends w of the hook-levers come in contact with the ear of corn m , and are held there until the

ear has been forced into the guides $S S$, and the arms $n n$ come in contact with the stops $v v$ on the stop-rods $R R'$, when the hook ends are forced open, and as the piston advances it is guided to the center of the ear of corn, and strikes and pushes the same centrally through the guides $S S$ and spring or flexible guides $s s$ into the V -shaped cutters $o^2 o^2$, which cut off the kernels of corn from the top and bottom of the cob, and as the ear reaches the front V -shaped cutters $o o^1$ the kernels of corn are cut from the sides of the cob. The cob is then pushed through between the scraper-wires $k k$, that are attached to the plate K' and end board N , where the juice and chit are scraped off, and the cob drops outside of the machine. The frame N , with the scraper-wires $k k$, slides in grooves formed in the inner sides of the side frames $A A$, to facilitate the removal thereof for cleaning or other purposes. On the return-stroke of the piston M the movable head or clamp $t' t'$ and hook-levers $w n$ return until they reach the front side of the rear end frame B^1 , which stops it, and the piston continues to move back until the hooks w close over the wooden end M' , after which the operation is repeated.

It will be observed that all parts of our machine operate from a central line common to all the moving parts, and that the ear of corn operates each guide $S S$, and the cob operates all the cutters, which adjust themselves centrally to all sizes of ears simultaneously.

What we claim as new, and desire to secure by Letters Patent, is—

1. The end frame B, with grooved rollers D and bell-crank levers $E E^1$, combined with the annular ring C and links $r r r r$, in the manner and for the purpose substantially as shown and described.

2. The end frame B, with grooved rollers D, bell-crank levers $E E^1$, combined with the annular ring C, links $r r r r$, and links $r^3 r^3 r^4 r^4$, and cutter-frames $G G' H H$, in the manner and for the purpose substantially as shown and described.

3. The cutter-frames $H H$, with curved cutters $o^2 o^2$, having V -shaped cutting-edges, combined with the links $r^4 r^4$, the levers $E^1 E^1$, the links $r r$, and annular ring C, in the manner and for the purpose substantially as shown and described.

4. The cutter-frames $G G'$, with curved cutters $o o^1$, having V -shaped cutting-edges, combined with the links $r^3 r^3$, the bell-crank levers $E E$, the annular ring C, the links $r r$, the lever k , and the spring d , in the manner and for the purpose substantially as shown and described.

5. The annular ring C, with lever K and spring d , combined with the frame B, in the manner and for the purpose substantially as shown and described.

6. The annular ring C' , with lever K' and spring d' , combined with the frame B and annular ring C, in the manner and for the purpose substantially as shown and described.

7. The annular ring C', with links $r^7 r^7$, combined with the levers E² E², and frame B, in the manner and for the purpose substantially as shown and described.

8. The annular ring C', with links $r^7 r^7$, combined with the bell-crank levers E² E², the frame B, and the horizontal adjustable corn-guides S S, in the manner and for the purpose substantially as shown and described.

9. The horizontal adjustable corn-slides S S, with guides $p p p' p'$ and flexible guides $s s$, combined with the guide-slides J J J' J', in the manner and for the purpose substantially as shown and described.

10. The movable spring friction-clamps $t' t'$, with hinges $t t$ and hook-levers $w n$, combined with the piston-rod M M' and stop-bars R R', in the manner and for the purpose substantially as shown and described.

11. The piston-rod M, with wooden end M', adapted to force the ear of corn from the hopper L' through the adjustable guides S S and the curved cutters $o o^1 o^2 o^2$, with V-shaped cutting-edges, in the manner and for the purpose substantially as shown and described.

12. The wire scrapers attached to the end board N, and adapted to remove the juice and chit from the cob, when said cob is forced through between them by the piston M M', in the manner and for the purpose substantially as shown and described.

13. The V-shaped corn-guides S S, having a positive connection with the annular ring C and a simultaneous movement laterally from a center line common to each other and to the curved cutters $o o^1 o^2 o^2$, in the manner and for the purpose substantially as shown and described.

14. The circular cutters $o o^1 o^2 o^2$, with V-shaped cutting-edges, having a positive connection with the ring C and a simultaneous movement laterally and vertically from a common center, in the manner and for the purpose substantially as shown and described.

15. The cutter-frames G G' H H, with knife-edges $g^2 g^2$, adapted to act as guides to the corn while it is passing from the flexible guides $s s$ into the cutters $o o^1 o^2 o^2$, and regulate the depth of cut of the cutters, in the manner and for the purpose substantially as shown and described.

In testimony whereof we have signed our names to this specification in the presence of two subscribing witnesses.

JAMES T. POLK.
OLIVER H. CASTLE.

Witnesses:

E. O. FRINK,
C. J. BRACKEBUSH.