

C. A. SMITH.  
Valve-Gear for Steam-Engine.

No. 203,662.

Patented May 14, 1878.

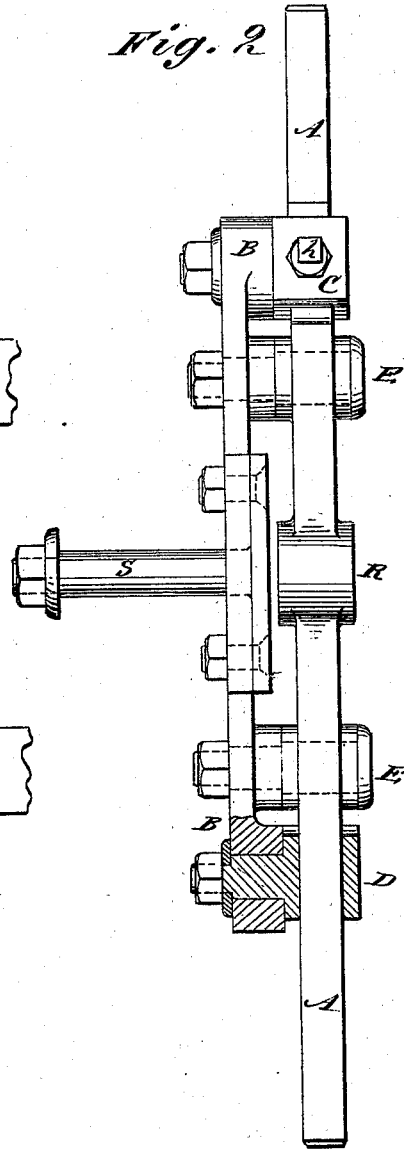
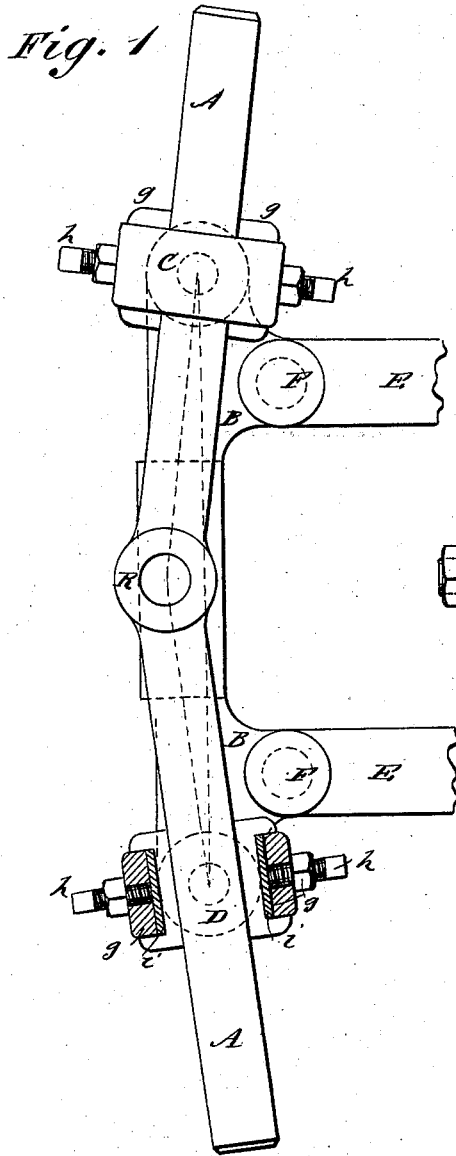

WITNESSES:

*C. Nevins*  
*C. Sedgwick*

INVENTOR:

*C. A. Smith*  
BY *Munroe*

ATTORNEYS.

# UNITED STATES PATENT OFFICE.

CHARLES A. SMITH, OF COLUMBUS, OHIO.

## IMPROVEMENT IN VALVE-GEARS FOR STEAM-ENGINES.

Specification forming part of Letters Patent No. 203,662, dated May 14, 1878; application filed April 23, 1878.

*To all whom it may concern:*

Be it known that I, CHARLES AUGUSTUS SMITH, of Columbus, in the county of Franklin and State of Ohio, have invented new and useful Improvements in Reversing-Links for Locomotives and other Reversible Engines, of which the following is a specification:

My invention relates to certain improvements the object of which is to overcome difficulties and disadvantages experienced in the use of the ordinary link or slotted bar, among which are the following: In the ordinary link the working-surfaces of both link and link-block must be perfectly true, and of the exact required radius, in order to fit nicely and work properly. This requires special machinery and skilled labor of a high order in fitting up the parts, especially where the working-surfaces are case-hardened.

When the ordinary link and link-block become worn so as to work loosely, there is lost motion of the valve, and this has always been an objectionable feature in the link-motion. To take up this lost motion requires in some cases a new link-block, and in all cases a complete refitting of the parts.

In designing link-motions, equalization must often be sacrificed for the purpose of reducing the slip and the consequent wear of the link-block, since this is the inevitable cause of the lost motion referred to. These and other disadvantages are entirely overcome by the use of my invention.

The invention consists in a novel construction and form of the link itself, and of an angle-bar employed in connection therewith in lieu of a link-block, together with certain details of construction, arrangement, and combination of devices, whereby a saving of time, labor, and machinery is obtained, and a simple, cheap, and accurately-working reversing mechanism is obtained.

My invention will be more fully understood on reference to the accompanying drawing, in which—

Figure 1 is a side view of a device embodying my improvements, and Fig. 2 an edge view, or at right-angles to Fig. 1.

Similar letters of reference indicate corresponding parts.

The link consists of a bar, B, which is solid

instead of slotted like the ordinary link. It is jointed to the eccentric-rods E E, and provided with a saddle-pin, S, midway of its length, for connection with the hanger, tumbling-shaft, &c., in the same manner as in the ordinary link.

Instead of a link-block, or a slide and pin, as used in connection with the ordinary link, I employ an angle-bar, A, which connects at its middle point, R, with the rocker-arm for operating the valve.

The bar A, from the point R outward in opposite directions, forms an obtuse angle, the sides of the angle—or, in other words, the two branches or arms of the bar—being perfectly straight and of uniform thickness throughout. These two arms or branches work in sockets C D, which are attached to the link B by pivots or swivel-joints, so as to allow them to oscillate as they slide on the bar A when the link is being raised or lowered. Each socket is furnished with gibs *g*, (see Fig. 1,) and with set-screws *h*, for tightening them when required, steel liners *i* being interposed to prevent the screws from eating into the brass gibs.

The parts thus constructed and arranged are attached to the engine in a similar manner and for the same purpose as the ordinary link. When the link is shifted up or down, the sockets C D slide on the angle-bar A, and thus the rocker-pin is caused to travel in the arc of a circle which is fixed in reference to and a certain distance from the eccentric-pins F. In this respect it resembles the ordinary link, and hence the motion imparted to the valve is the same.

The principle upon which this invention is based is found in the simple geometrical proposition that if two right lines, C R and D R, (see dotted lines in Fig. 1,) intersect, making a constant angle with each other, their point of intersection, R, will describe a circle when the lines are respectively moved along the fixed points C and D. Hence, to determine the angle of the bar A for a given radius of link, describe a circle with the desired radius, and take any two points, as C and D, in the circumference of this circle, making the chord equal to the distance C D. This distance, of course, is determined from the length of the link. Next, assume any other point, as R, in the

circumference of the circle, and join this point with the points C and D by the straight lines C R and D R. The angle C R D will be the required angle for the radius assumed.

In the link or bar B, Fig. 1, the points C and D are determined in the same manner, and the points F F and the saddle-pin S are set the required distance from an arc drawn through the points C R D, which is the link-arc.

Among the advantages resulting from the construction shown in my invention are the following: The working or sliding surfaces are straight, requiring no special machine for planing a circle, as with the ordinary link. The planer work can be done on an ordinary planer, and it requires less time and labor to fit up than the ordinary link. There need be no lost motion, such as results from wear and friction of the link-block, as in the ordinary link, for, if the bar A, from wear and friction, becomes loose in the sockets, the defect may be immediately remedied by simply tightening the set-screws and setting the

gibs closer to the bar. It is evident, then, that this device will cost less for repairs than the ordinary link, besides improving the valve-motion.

In this invention the motion may be equalized, as near as possible, without regard to the slip, because the lost motion can be readily taken up. Hence this link enables us to better equalize the valve-motion, and to simplify the problem of the link-motion by eliminating the slip from its solution.

Having thus described my invention, I claim as new and desire to secure by Letters Patent—

The combination, with a reversing-link connected with reversing mechanism, of an angle-bar, constructed as described, connected with the valve-operating mechanism, and arranged to operate substantially as and for the purpose herein set forth.

CHARLES A. SMITH.

Witnesses:

DANIEL ROSS,  
JOHN PATON.