

J. W. SPRAGUE.
Freight-Car Truck.

No. 203,665.

Patented May 14, 1878.

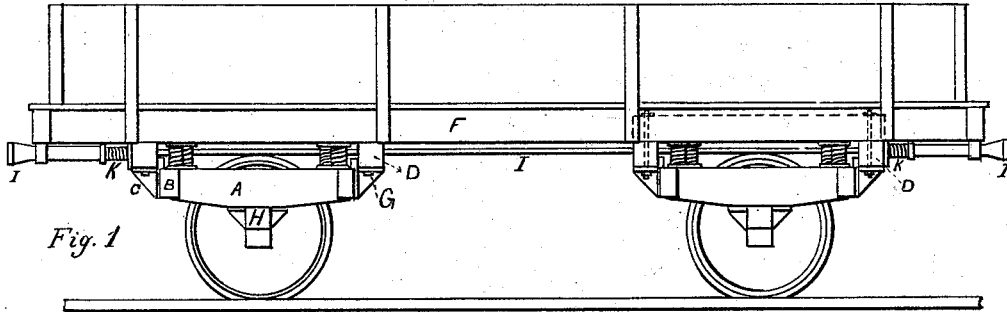

Fig. 1

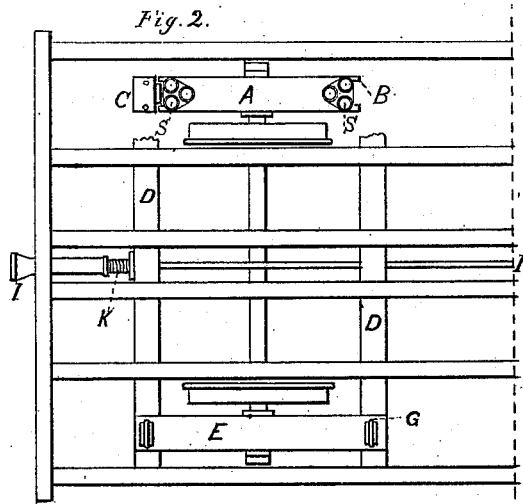

Fig. 2.

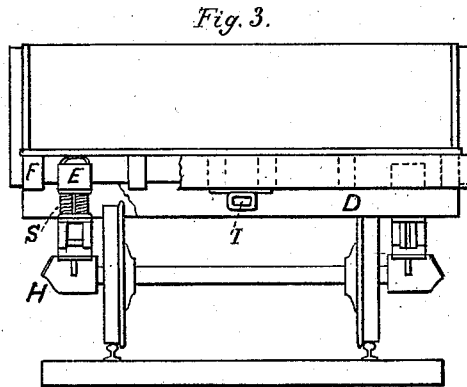

Fig. 3.

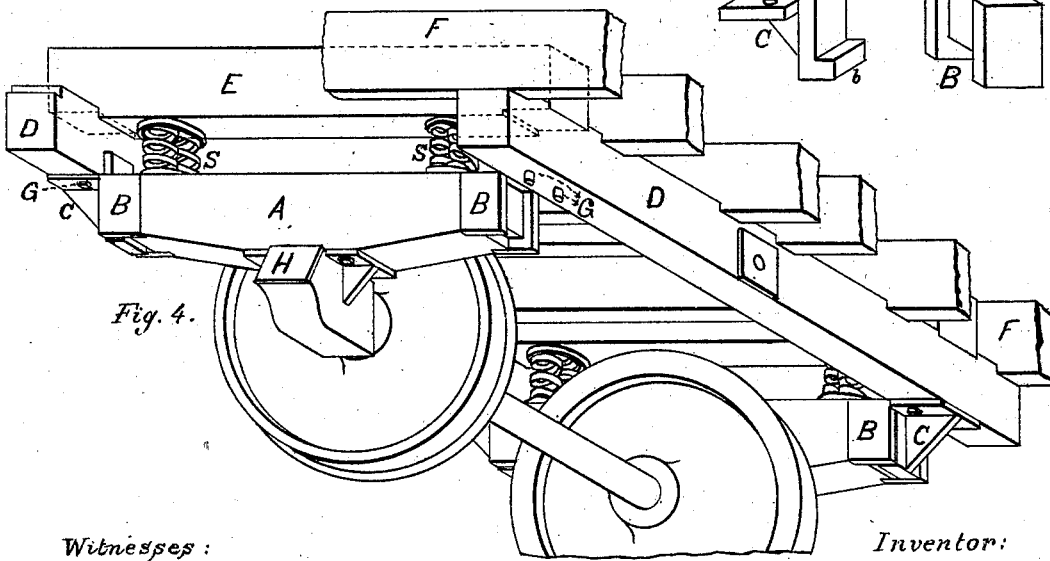

Fig. 4.

Fig. 6.

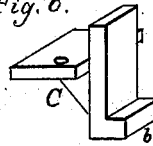
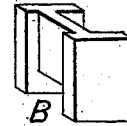

Fig. 5.



Witnesses:
A. C. Godman.
E. B. Sippett.

Inventor:
Jas. W. Sprague

UNITED STATES PATENT OFFICE.

JOSEPH W. SPRAGUE, OF JEFFERSONVILLE, INDIANA.

IMPROVEMENT IN FREIGHT-CAR TRUCKS.

Specification forming part of Letters Patent No. 203,665, dated May 14, 1878; application filed December 12, 1877.

To all whom it may concern:

Be it known that I, JOSEPH W. SPRAGUE, of the city of Jeffersonville, county of Clark, and State of Indiana, have invented certain Improvements in Four-Wheel Freight-Cars for Railroads, of which the following is a specification:

The object of my invention is to modify the ordinary construction of four-wheel cars, so as to enable them to ride more smoothly over uneven track, adapt themselves more readily to sharp curvatures, and carry an increased percentage of load as compared with weight of car.

Figure 1 represents a side view of a four-wheel car. Fig. 2 represents a ground plan of the same with the flooring and a portion of the timbers removed. Fig. 3 represents an end view of the same with a portion of the end sill removed. Fig. 4 represents a perspective view of the frame-work of the car and its connections with the wheel-pieces, journal-boxes, axles, and wheels. Figs. 5 and 6 represent perspective views of details, more particularly described hereinafter.

D D represent four transom-timbers, which extend across the car its entire width and receive the whole weight of the car-body and its load. These transoms give to the body of the car four lines of support, nearly equally distributed, and consequently enable the same amount of strength to be secured for the body with a less expenditure of material than would be possible if the body of the car transmitted its weight to the journals at four points directly over them, as is the case in the ordinary forms of construction, where only two transoms or their equivalents are employed.

A A represent wheel-pieces, to which are secured the journal-boxes H H, within which are placed the bearings for the journals of the axles to revolve in. E E are spring-timbers, to which the transoms D D are attached, or upon which they may rest, as preferred. Upon the said wheel-pieces, at or near each end, are placed springs S S, upon which the spring-timbers E E rest, whereby the weight of the car is transmitted from the transom through the spring-timbers and springs to the wheel-pieces. These wheel-pieces are free (within certain limits subsequently described) to revolve

on the journals, and thus equalize the action of the springs under unequally-distributed loads or over uneven track.

C C represent column-guides attached to the transoms of the car, and playing vertically in the slides B B attached to the wheel-pieces. *b* represents a lip cast on the column-guide C, which catches under the slide B and limits the motion of the wheel-piece as it revolves around the journal, or as the car-body is thrown up by the sudden recoil of the springs.

The wheel-pieces A A, the column-guides C C, and the slides B B all admit of various constructions. The wheel-pieces may be constructed of wood or of iron, or of the two combined. They may be placed over the journal-boxes or under them, or partly over and partly under them. For the column-guide and slide may be substituted any equivalent device attached to or forming part of the body of the car, playing in or on any equivalent device attached to or forming a part of the wheel-pieces, by which combined devices all lateral or horizontal movement of the wheel-pieces independent of the body of the car is prevented, while the said pieces are allowed to have a restricted rotary independent movement on the axles, as described, and the said devices also permitting an independent vertical motion of the car-body and of the wheel-pieces independent of each other as the springs are brought into action.

To limit the motion of the wheel-pieces, in place of the lip *b* acting on the slide B, any equivalent device accomplishing the same result may be substituted, whether attached to the column-guide and slide or to the body of the car and the wheel-pieces—as, for example, a chain bolted to both, and checking their relative motions when the chain becomes tight. So long as the wheel-pieces are free to revolve on the journal within the limits previously described, and there is the independent relative vertical movement of the said pieces and the car-body, as described, and yet are so confined as to have no lateral or horizontal motion independent of the car-body beyond a slight play essential to the freedom of the motions previously described, the conditions essential to their successful action are fulfilled.

The transoms may transmit the weight of

the car and load to the wheel-pieces in various ways. One of these is shown in the drawing, where it is accomplished through the intervention of the spring-timbers E E bolted to the transoms. Another way would be to allow the wheel-pieces to pass under the transoms and place the springs between the transoms and the wheel-pieces. This form of construction admits of the use of a continuous draw-bar without the heavy and bulky attachments ordinarily required.

I I represent a continuous draw-bar, with the buffer-springs K K acting directly on the end transoms.

To protect the end transom from the action of the buffer-spring, a plate of iron may be placed between them.

What I claim as my invention, and desire to secure by Letters Patent, is—

1. The combination, with the body and axle of a railway-car, of transoms D D, wheel-pieces A A, and springs S S, as and for the purpose described.

2. The transoms D D and wheel-pieces A A, provided with the guides C and slides B, whereby the pieces A A are permitted to have a restricted rotary movement on their axes independent of the car-body, while they are not allowed to have any independent lateral or horizontal movement, as and for the purpose described.

JOS. W. SPRAGUE.

Witnesses:

E. B. TIPPETT,
HARRY C. GODMAN.