

P. S. SWAIN.
 Combined Nozzle and Tap.

No. 203,672.

Patented May 14, 1878.

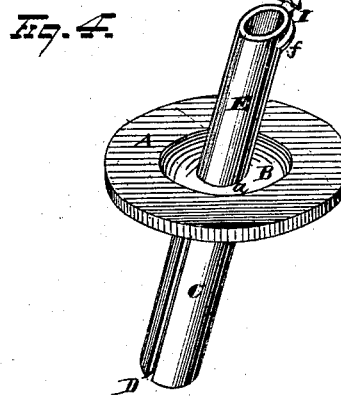
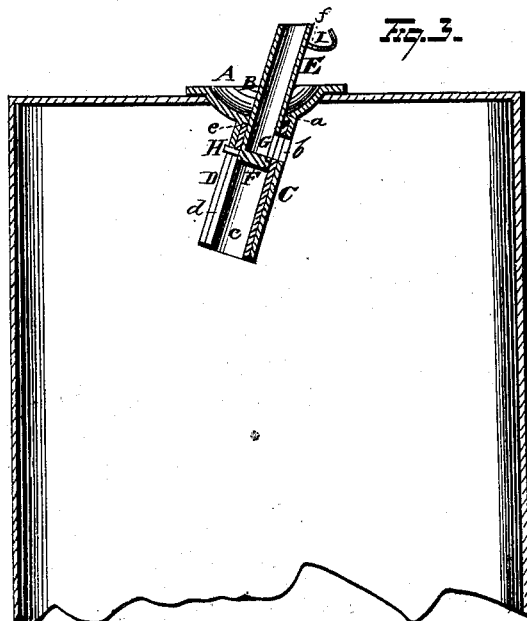
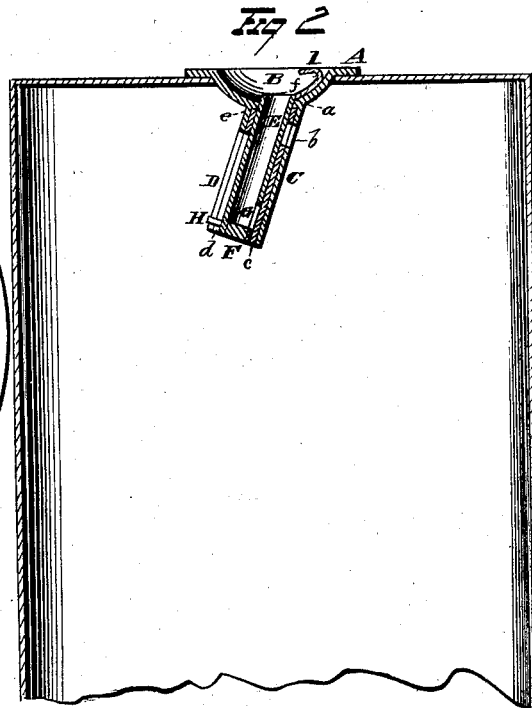
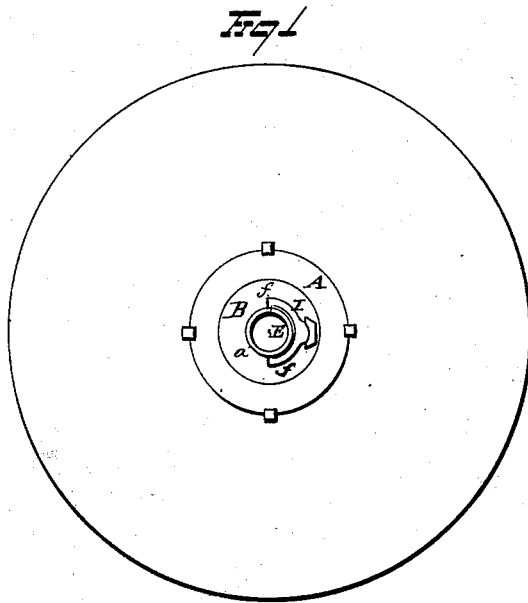

WITNESSES

E. J. Attridgeham
A. W. Bright

INVENTOR

Philip S. Swain

By H. A. Seymour.

ATTORNEY

UNITED STATES PATENT OFFICE.

PHILIP S. SWAIN, OF NEW YORK, N. Y.

IMPROVEMENT IN COMBINED NOZZLE AND TAP.

Specification forming part of Letters Patent No. 203,672, dated May 14, 1878; application filed April 3, 1878.

To all whom it may concern:

Be it known that I, PHILIP S. SWAIN, of New York, in the county of New York and State of New York, have invented certain new and useful Improvements in Combined Nozzle and Tap; and I do hereby declare the following to be a full, clear, and exact description of the invention, such as will enable others skilled in the art to which it pertains to make and use it, reference being had to the accompanying drawings, which form part of this specification.

My invention relates to an improvement in combined nozzle and tap for oil-vessels.

The object of the invention is to provide oil-vessels with a nozzle which may be forced into the vessel and close the oil-exit opening, and thus allow the can or other vessel to be transported without injury to the nozzle, while the latter, when pulled outwardly, opens the oil-discharge port, and allows the oil to be discharged through the nozzle when thus extended.

My invention consists, first, in the combination, with a disk provided with an open-ended slotted tube having a port in close proximity to the disk, of a sliding nozzle provided with a projection, which enters the slot in the tube, whereby the nozzle and tube are retained in the same relative position to each other.

My invention further consists in the combination, with a disk the central portion of which is cup-shaped, and a slotted tube attached to the convex surface of said cup-shaped portion, of a sliding nozzle constructed with a closed inner end, and provided with a port which registers with a port in the slotted tube when the nozzle is extended for use, and furnished with a pin or projection that engages in a slot formed in the stationary tube.

My invention further consists in the several details of construction and arrangements of parts, as will hereinafter be described, and pointed out in the claims.

In the accompanying drawings, Figure 1 is a plan view of my improvement. Fig. 2 is a vertical section, showing the relative position of the several parts when the tap is closed. Fig. 3 is a similar view, illustrating the tap

when open for use; and Fig. 4 is a detached view of the device.

A represents a disk, which may be made of brass, tin, or of any suitable material, and is formed with a central cup, B, which latter has a central opening, *a*, formed therein. To the under surface of the cup B is rigidly secured, by soldering or otherwise, a tube, C, which is provided with a slot, D, extending nearly or quite its entire length, and opposite the slot D is formed an opening or port, *b*, the latter being located in close proximity to the cup B. Tube C is provided with a lining, *c*, preferably of leather, although said lining may be formed of wood or any equivalent material. Lining *c* is split at *d*, and one end rests against the annular flange *e*, formed by that portion of cup B which overlaps the end of the tube C. The opposite end of lining *c* extends out flush with the lower end of said tube. E represents a sliding nozzle, the inner end of which is furnished with a tight cap or plug, F. One side of nozzle E is provided with a port, G, which registers with port *b* when the nozzle is fully extended. H is a pin or projection attached to or formed on the rear end of the nozzle E. Pin H enters the slits D *d* in the tube and its lining, and serves to prevent any rotary movement of the sliding nozzle within its tube or sleeve, and thus insures the exact registering of the ports *b* and G of the tube and sliding nozzle, and also prevents the complete withdrawal of the nozzle from the stationary tube. I is a catch-piece, the arms *f* of which are swiveled to the outer end of the sliding nozzle.

When the nozzle is forced into the can, or other receptacle to which the device is attached, the catch-piece I is received in the cup B, so that it cannot be injured in transportation.

It is evident that a lip may be formed on the end of the sliding nozzle, which will serve the same purpose as the catch-piece I, and hence I do not limit myself to the exact construction shown and described.

I have represented the tube and sliding nozzle secured to the disk at an inclination, to secure the desired inclination or dip of nozzle when oil is to be discharged from the

vessel; but these parts may be arranged at right angles to each other, or in any other manner desired.

The lining of leather is kept thoroughly lubricated by the contained oil in the vessel, thus always insuring a tight joint between the stationary and sliding tubes.

When the cans are being transported, the nozzles are located within the vessel, and thus prevented from displacement or injury. All waste of oil is prevented, as each can is furnished with means for opening and closing without puncturing the can or vessel.

These combined nozzles and taps may be furnished to the trade as an article of manufacture, as they are adapted to be applied to any form of vessel for storing and transporting oil or other liquids.

Having fully described my invention, what I claim as new, and desire to secure by Letters Patent, is—

1. A disk having an open-ended slotted tube secured thereto, said tube provided with a port located in close proximity to said disk, in combination with a sliding nozzle having a closed inner end, a port located near its inner or lower end, and a pin or projection which

enters and engages the slot in the stationary tube, substantially as set forth.

2. The combination, with a disk formed with a cup-shaped center, and provided with a slotted tube, of a sliding nozzle having a side discharge-port, and a pin or projection that engages with the slot in the stationary tube, substantially as set forth.

3. In a tap for oil-cans, the combination, with a disk provided with an open-ended slotted tube having a port located in close proximity to said disk, of a sliding nozzle having a closed inner end, a port located near its inner or lower end, a slotted lining of leather or equivalent material placed within the slotted tube, and a pin or projection attached to the sliding tube, which engages the slot in the stationary slotted tube, substantially as set forth.

In testimony that I claim the foregoing I have hereunto set my hand and seal this 30th day of March, 1878.

PHILIP S. SWAIN. [L. S.]

Witnesses:

EDWD. A. LOVELL,
N. E. MATHEWS.