

J. COCHRANE.
Stay-Bolt Trimmer.

No. 203,708.

Patented May 14, 1878.

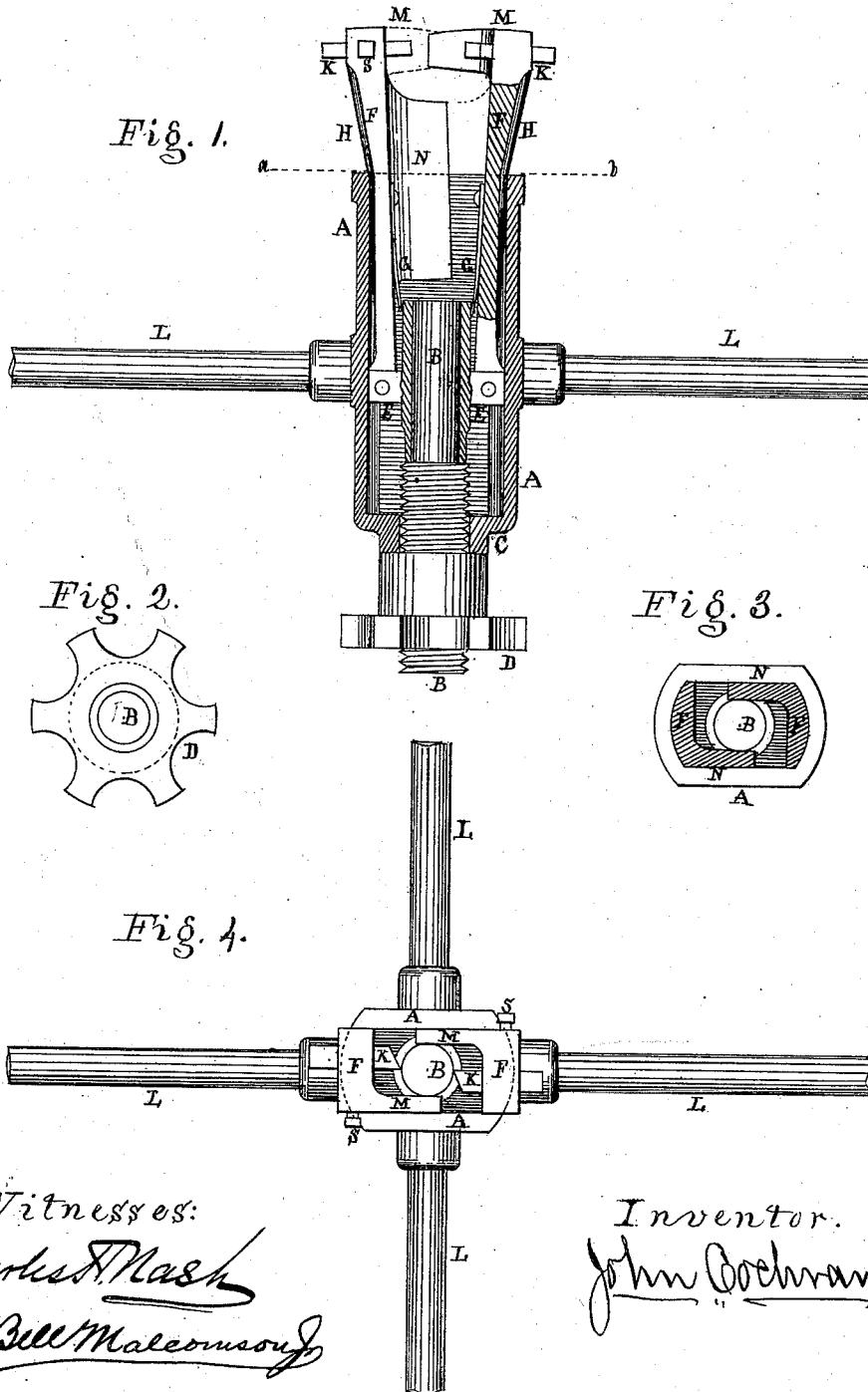

Witnesses:
Charles Mash
Abell Malcolmson

Inventor:
John Cochrane

UNITED STATES PATENT OFFICE.

JOHN COCHRANE, OF NEW YORK, N. Y., ASSIGNOR TO COCHRANE BROTHERS,
OF FARMINGDALE, N. J.

IMPROVEMENT IN STAY-BOLT TRIMMERS.

Specification forming part of Letters Patent No. **203,708**, dated May 14, 1878; application filed August 10, 1874.

To all whom it may concern:

Be it known that I, JOHN COCHRANE, of the city and county of New York, and State of New York, have invented a new and useful instrument or tool for cutting off or trimming the stay-bolts of steam-boilers when screwed into place, and for other purposes; and I do hereby declare that the following is a full and exact description of the construction and operation of the same, reference being had to the accompanying drawings, and to the figures and letters marked thereon, and in which—

Figure 1 is an axial longitudinal section, showing the several parts in position; Fig. 2, front view of the feed-nut; Fig. 3, rear view of the outer shell and cross-section of the cutter-levers in the line *a b* of Fig. 1; Fig. 4, rear elevation of the instrument.

The same parts are indicated by the same letters in all the figures.

Locomotive and other steam-boilers constructed with internal furnaces have water-spaces surrounding or inclosing such furnaces, composed of flat parallel plates, which plates are secured to each other at numerous points by what are termed "stay-bolts," which are pieces of round bar-iron having screw-threads cut or formed upon their surfaces from end to end. These stay-bolts are screwed through both the outer and inner plates of the water-spaces, and the ends are made to project about a quarter of an inch beyond the surface of the plates, which projections are riveted over so as to make a perfectly secure and tight joint.

Stay-bolts were usually made in pieces of sufficient length to contain three or four of the bolts, and with a square tenon on one end for the wrench, by which to screw them into the boiler. When one stay-bolt was screwed into place the remainder of the piece was cut off and again screwed into the boiler, and so on till used up; but the great difficulty heretofore experienced from cutting off the iron was the upsetting and bruising of the screw-thread, in consequence of which difficulty it is now usual to make the stay-bolts in single lengths only, and with a square tenon on each, thus nearly or quite doubling the cost of their production.

The object of my invention is to cut off and trim the stay-bolt when in place without in-

juring the screw-thread, and also without jarring the hold of the stay-bolt in the boiler, all which I accomplish by means of my stay-bolt trimmer with its rotary and converging cutters in substitution of the chipping and hammering process which is now in general use, thereby enabling the manufacturer to make any convenient number of stay-bolts in one piece, and thus effecting a considerable saving in both labor and material.

In Fig. 1, A A is the body or outer shell of the stay-bolt trimmer, and it may be of rectangular section, or of the form shown in Fig. 3, which is a cylinder with flattened sides. In the center or axis of this body or shell is the sliding screw B B, which is bored out to a size a little larger than the outer diameter of the screw-threads of the proposed stay-bolts. This sliding screw passes freely through the neck C of the outer shell A A, and has upon its outer end the feed-nut D, which bears against the neck C. The sliding piece or screw B B has two lugs, E, arranged on its opposite sides near the inner end, to which lugs the two cutter-levers F are jointed or pivoted. The cutter-levers F are pressed outward by the expanding springs G, which are attached to the levers, and react or bear by their points upon the inner end of the sliding piece B B, so as to keep the levers open and in contact with the lips of the outer shell A A, as shown in Fig. 1.

Upon the outer ends of the levers F, and on their exterior sides, I form the inclined planes H, for a purpose to be presently explained, and through the outer ends of these levers I insert the steel cutters K and secure them in place by the set-screws S, as shown in Figs. 1 and 4.

When the several parts of the instrument are in the positions shown in Fig. 1, the edges of the cutters K should be near the surface of the stay-bolt which is to be cut off or trimmed. It will now be observed that if the feed-nut D is rotated on the sliding screw B B, so as to bear against the neck C of the outer shell A A, the two cutter-levers F will be drawn into the shell A A, and while they are being thus drawn in the lips of the shell A A will compress the outer ends and cause them

to approach each other by acting on the inclined planes H, and thereby converge the cutters K upon the stay-bolt, so as to cut into it.

The tool or trimmer being attached to and fixed upon the stay-bolt by the gripe of the two cutters on its opposite sides, it is then rotated on its axis by the hand-levers L, which are screwed into bosses cast on the outer shell A A, and while being thus rotated each of the cutters K removes a shaving of iron from the stay-bolt, when the feed-nut D is again tightened so as to set in the cutters, and so on till a groove of sufficient depth is cut around the stay-bolt to permit of its being easily broken off.

To prevent the cutters from catching or chattering when the iron is seamy or the feed too great, I make a steady-bearing, M, upon each of the levers F in front of the cutters, and so as to bear against the sides of the stay-bolt, as shown in Figs. 1 and 4. I also make a side bearing, N, upon each of the cutter-levers F, to bear upon the inner flat sides of the shell A A, and extending beyond the edge of the cutters, as shown in Fig. 1, and in section within the shell A A, Fig. 3, through the line *a b*, Fig. 1, thus preventing the torsion of the levers F, which would otherwise take place from the action of the cutters upon the stay-bolt.

I do not limit myself to the exact details of construction or arrangement of the parts herein shown, as these may be varied without thereby changing the principle of the invention. Thus the cutter-levers may be jointed or pivoted at midlength to the outer shell instead of to the sliding screw, and be converged upon the stay-bolt by a sliding or feed screw having inclined planes attached to it, and other changes might be suggested without altering the principle or character of the device.

In the manufacture of these stay-bolt trimmers I prefer to make the outer shell, sliding screw, feed-nut, and cutter-levers of steel cast-

ings; but composition, malleable iron, or cast-iron may be used, if preferred.

Having thus described my improved stay-bolt trimmer, and the manner of constructing and using the same, what I claim therein as my own invention, and desire to secure by Letters Patent of the United States, is—

1. A stay-bolt trimmer or cutter having the cutters attached to the outer ends of vibrating levers, arranged on opposite sides of the axis of the instrument, and jointed or pivoted at their inner ends to the feeding mechanism, by which the said levers are made to converge and impinge the cutters against the bolt or object to be severed, or to recede therefrom when so required, constructed and operating substantially as herein described.

2. The combination of the outer shell A, cutter-levers F, cutters K, hollow sliding screw B, and feed-nut D, constructed and operating in the manner and for the purpose substantially as herein described.

3. The stay-bolt trimmer having cutter-levers F, with inclined planes H formed on their outer ends, in combination with the outer shell A and the feeding mechanism for setting in the same, constructed and operating in the manner and for the purpose substantially as herein described.

4. The stay-bolt trimmer having cutter-levers F, and steady-bearings M attached thereto, constructed and operating in the manner and for the purpose substantially as herein described.

5. The stay-bolt trimmer having cutter-levers F, with side bearings N attached thereto, constructed and operating in the manner and for the purpose substantially as herein described.

JOHN COCHRANE.

Witnesses:

P. D. SCOTT,

A. BELL MALCOMSON, Jr.