

C. B. COTTRELL.
 Sheet-Delivery Apparatus for Printing-Machines.

No. 203,709.

Patented May 14, 1878.

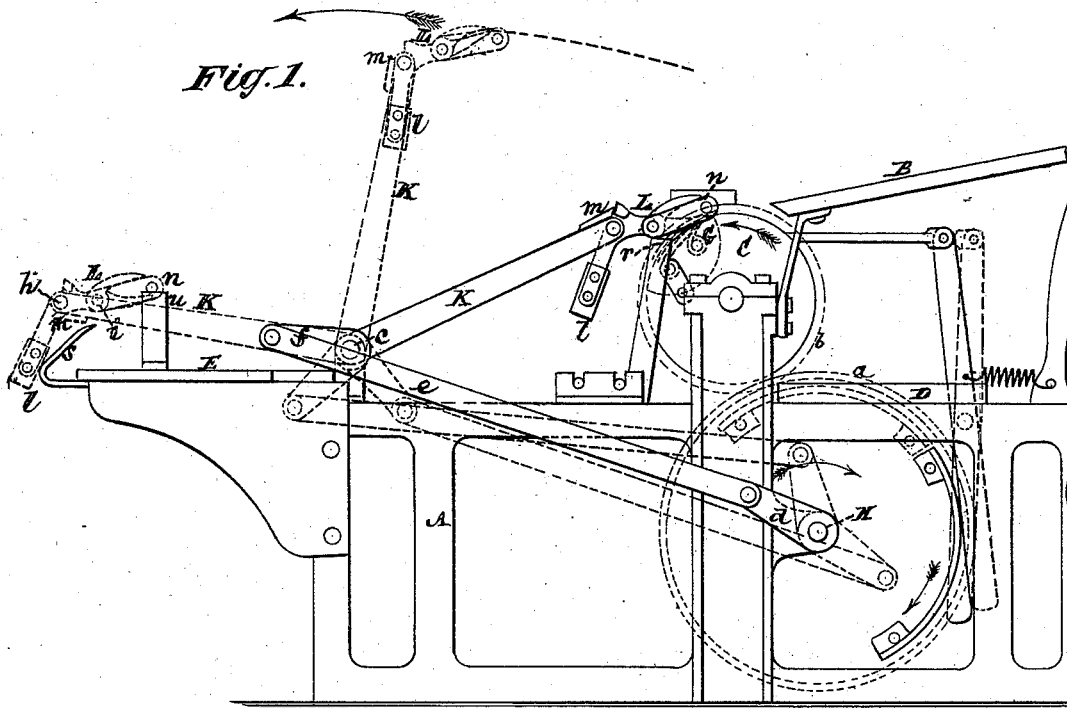
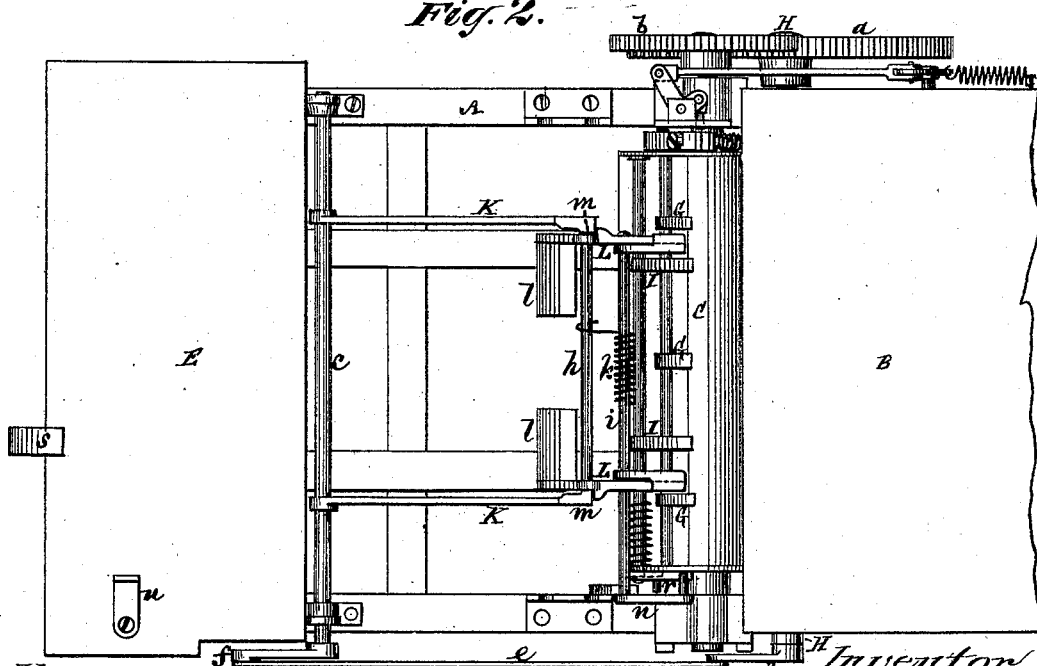

Fig. 2.



Witnesses
 John Decker
 and Wagner,

Inventor
 C. B. Cottrell
 by his Attorneys
 Brown & Allen

UNITED STATES PATENT OFFICE.

CALVERT B. COTTRELL, OF WESTERLY, RHODE ISLAND.

IMPROVEMENT IN SHEET-DELIVERY APPARATUS FOR PRINTING-MACHINES.

Specification forming part of Letters Patent No. **203,709**, dated May 14, 1878; application filed December 10, 1877.

To all whom it may concern:

Be it known that I, CALVERT B. COTTRELL, of Westerly, in the county of Washington and State of Rhode Island, have invented certain new and useful Improvements in Sheet-Delivery Apparatus for Printing-Machines, of which the following is a description, reference being had to the accompanying drawing, forming part of this specification.

This invention more particularly relates to printing-presses in which a reciprocating type-bed is combined with a rotating impression-cylinder, and is applicable alike to stop-cylinder presses, in which the impression-cylinder remains stationary during the travel of the reciprocating bed in one direction, and to two-revolution cylinder presses, in which the impression-cylinder has a continuous motion, but makes two revolutions for each travel of the bed in opposite directions.

One of the objects of the invention is to obviate the necessity of putting a delivery-fly under the feed-board of such presses, and thereby to afford all desirable facility for putting in the forms, overlaying, and underlaying, and correcting them.

Another object of the invention is to transfer the sheet from the impression-cylinder to the receiving bed or table with its printed face uppermost, and to pile the sheets uniformly on said table without having resort to a fly operating to receive the printed surface of the sheet on its face, which is apt to smut the sheet.

To these and other ends the invention consists in a combination of a vibrating fly-frame, having attached grippers for floating or carrying the sheet by its one edge, a reciprocating type-bed, a rotating impression-cylinder, a feed board or table for feeding the sheet to said cylinder, and a sheet-receiving table or board on the opposite end of the machine to that occupied by the feed-board.

The invention also consists in the combination, with a vibrating or swinging fly-frame, of grippers, which are so pivoted to the said frame and counterbalanced by weights as to keep their jaws in, or nearly in, a horizontal position, whereby, after taking the sheet from the cylinder by seizing one edge, they are enabled

to carry it floating in the air, and without other support, to the receiving-table.

It furthermore consists in certain means of effecting and controlling the necessary movement of the grippers by which they seize the sheets in taking them from the impression-cylinder and liberate them, to deposit them on the receiving-board.

Figure 1 represents a side elevation of a printing-press, in part, in which a two-revolution impression-cylinder is combined with a reciprocating type-bed with my invention applied; and Fig. 2 is a plan of the same.

A is the main frame of the press, which frame may be of any suitable construction; B, its feed board or table; C, its impression-cylinder; D, the reciprocating type-bed; and E, the receiving board or table for the printed sheets. G G are the grippers of the impression-cylinder, and I a shoo-fly, which may or may not be combined therewith. The means for operating the impression-cylinder, its grippers, shoo-fly, and the type-bed may be similar to those usually employed in other presses; and the relative action of said devices is or may be the same, the two-revolution impression-cylinder being here represented as receiving its motion from a shaft, H, by gearing *a b*.

K is the vibrating or rocking fly-frame, carried by a cross lower shaft, *c*, which forms part of it, and which is arranged immediately in front or over the forward edge of the sheet-receiving board or table E, which latter is arranged at the opposite end of the press to that occupied by the feed-board. Said fly-frame H is here represented as being rocked forward and backward, to take the sheet from the impression-cylinder and to convey it to or over the receiving-board by means of a crank, *d*, on the shaft H, connecting-rod *e*, and a crank, *f*, on the shaft *c* of the fly-frame; but a cam or any other suitable motion may be substituted for the crank-movement.

L L are the grippers or nippers of the rocking fly-frame K. The lower jaws of these grippers are rigidly attached to a spindle, *h*, which pivots them to the fly-frame K, being fitted to rock freely in bearings in the outer ends of the said frame; and the upper jaws of the said grippers are pivoted to the lower ones

by a spindle, *i*, to which is applied the spring *k* for closing them. The said spindle *h* has also secured to it weighted arms or weights *l*, which so counterbalance the grippers that, although the fly may swing nearly half a circle in its movement from the impression-cylinder to the receiving-board, the jaws of the grippers, being capable of a swinging movement independent of the swinging movement of the grippers, remain in a horizontal position, or as nearly so as may be desired, during their entire movement, and so avoid turning over the sheet, and deposit it upon the receiving-table with its printed side upward. The sheet, being held at the front edge only by the so-called grippers, is, by the long swing of the fly and its rapid motion, carried flying, nearly edgewise, through the air, although the fly turns almost over.

In order to make a rigid connection between the lower jaws of the grippers and the fly-frame *K* at the time of taking the printed sheet from the cylinder, there are provided on the fly-frame stops *m*, against which shoulders on the arms of said jaws, are brought in contact, as shown in Fig. 1, by the weights *l*, when the fly arrives in a position to take the sheet. After the shoulders have thus come in contact with the stops *m* the grippers *L L* are opened to take the sheet by a stud on an arm, *n*, fast on the spindle *i*, which carries the upper jaws, coming down on a cam, *r*, carried by the impression-cylinder. So soon, however, as said cam has passed from under the stud of the arm *n* the grippers *L* close on the sheet by the action of the spring *k*, and the swinging grippers afford all the necessary accommodation, and yield in starting back with the sheet as the rocking fly-frame commences to rise and move from the impression-cylinder toward the receiving-board *E*.

As the rocking fly-frame *K* completes its backward movement to deposit the sheet on the pile, either weight of the grippers *L* passes down or over a stop, *s*, which serves to keep the grippers in proper position for delivery of

the sheet and for laying or gently dropping it on the pile in a uniform manner, and for making a uniform pile, the spring-jaws of the grippers *L* being opened when delivering the sheet by the stud on its arm *n* striking a fixed stop, *u*, as the weighted grippers rest on or are supported by the stop *s*.

What I claim as my invention, and desire to secure by Letters Patent, is—

1. The combination, in a cylinder-press having a reciprocating type-bed, of a feed-table, *B*, at one end of the press, a receiving board or table, *E*, at the opposite end thereof, and a vibrating or swinging fly-frame, provided with grippers and detached from the type-bed, and operating between the impression-cylinder and the receiving-table, to take the sheet from said cylinder and deposit it upon said table, substantially as herein described.

2. The combination, with grippers pivoted into a swinging fly-frame, substantially as herein described, of counterbalancing arms or weights applied to the said grippers, substantially as herein described, whereby they are maintained in a horizontal, or approximately horizontal, position during the whole movement of the fly-frame, as herein set forth.

3. The combination, with the vibrating or swinging fly-frame and counterbalanced grippers pivoted therein, substantially as herein described, of one or more stops, *m*, on the said fly-frame, against which the grippers are brought and held by their counter-balances preparatory to and during their opening to take the sheet, substantially as and for the purpose herein set forth.

4. The combination, with the vibrating or swinging fly-frame and counterbalanced grippers pivoted therein, of one or more fixed stops, *s*, for supporting and directing the said grippers at the time of their delivery of the sheet, substantially as herein described.

C. B. COTTRELL.

Witnesses:

HENRY T. BROWN,
FRED. HAYNES.