

L. PATTERSON.  
Grinding-Machine

No. 203,762.

Patented May 14, 1878.

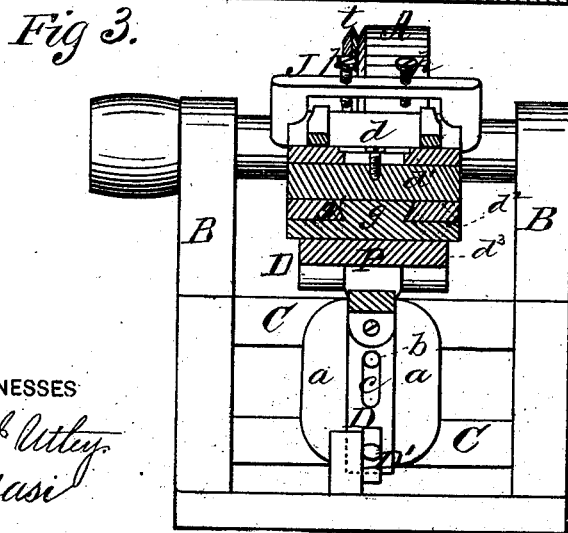
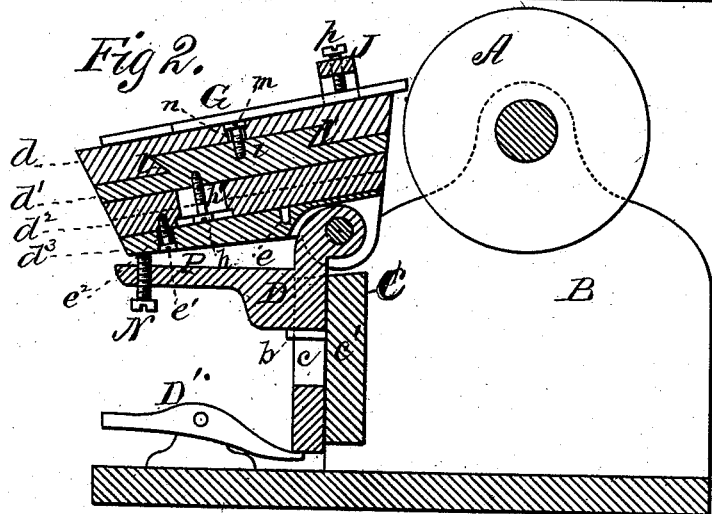
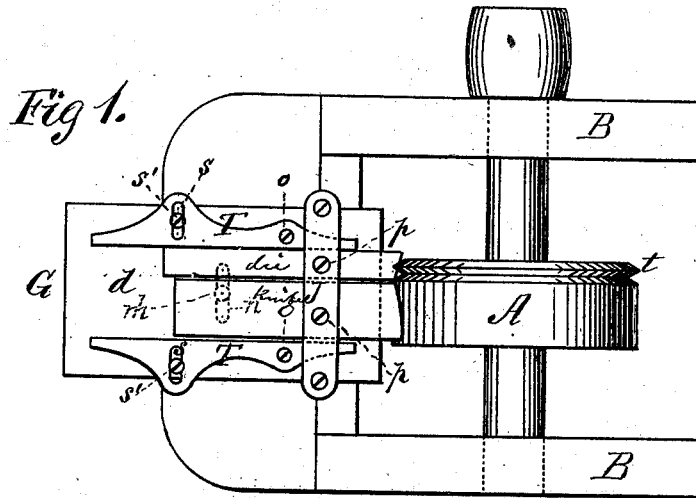

WITNESSES

Mary S. Utley  
F. J. Masi

INVENTOR

Lewis Patterson,  
by E. M. Anderson

ATTORNEY

# UNITED STATES PATENT OFFICE.

LEWIS PATTERSON, OF TERRE HAUTE, INDIANA.

## IMPROVEMENT IN GRINDING-MACHINES.

Specification forming part of Letters Patent No. 203,762, dated May 14, 1878; application filed March 16, 1878.

*To all whom it may concern:*

Be it known that I, LEWIS PATTERSON, of Terre Haute, in the county of Vigo and State of Indiana, have invented a new and valuable Improvement in Knife and Die Grinders for Tack and Nail Machines; and I do hereby declare that the following is a full, clear, and exact description of the construction and operation of the same, reference being had to the annexed drawing, making a part of this specification, and to the letters and figures of reference marked thereon.

Figure 1 of the drawing is a representation of a top view of my improved knife and die grinder. Fig. 2 is a longitudinal vertical section thereof, and Fig. 3 is a vertical cross-section of the same.

This invention has relation to improvements in machines for grinding the knives and dies of tack and nail machines.

There are to each machine two knives and two dies, which must be ground to a uniform bevel and a uniform shear from left to right, which must be slightly rounding or convex, and absolutely smooth and true on their edge or face, with no seams, ruts, or ridges, and which, finally, must be concave upon one of their faces in order to do correct work.

The object, then, of my invention is to devise a machine which will grind the dies and knives with absolute exactness.

The nature of the invention consists in certain novel combinations of parts whereby the above-recited results are obtained, as will be hereinafter more fully set forth.

In the annexed drawing, the letter A designates a grindstone rotating in the pillow-blocks B, and actuated by means of pulleys and an endless belt, in the usual way. I may, however, use a system of gears for the same purpose when expedient. The blocks B are braced by the spaced cross-pieces C at one end, and upon these cross-pieces are secured the ways *a*, in which is placed, after the manner of a sash, an angular metallic slide, D, whose motions are regulated by means of a set-screw, *b*, extending through a slot, *c*, in the said slide into a brace, *c'*, connecting the cross-pieces C. The lower end of the angular slide D rests upon a treadle-lever, D', that serves to raise the slide aforesaid by pressing

down upon its power end with the foot. The tool-rest G is composed of the independent sections *d* *d*<sup>1</sup> *d*<sup>2</sup> *d*<sup>3</sup>, laid the one upon the other, with the lower section *d*<sup>3</sup> hinged to the slide, so as to vibrate vertically. This is accomplished by means of two spaced lugs upon the under side of the rest-section, between which is received a lug at the upper end of the slide and a hinge-pin passing through registering-perforations in the said lugs. The section *d*<sup>2</sup> is pivoted to the section *d*<sup>3</sup> near its front end by means of a bolt, *e*, and is adjusted by means of a screw, *e*<sup>1</sup>, extending through a curved slot, *e*<sup>2</sup>, in the rest-section *d*<sup>3</sup>, into the section *d*<sup>2</sup> aforesaid. This construction allows the rest to be adjusted in the arc of a circle to form the shear of the nail-tool. The section *d*<sup>2</sup> has upon its top a longitudinal dovetail tongue, *g*, that is received in a corresponding groove, *g'*, upon the under side of the section *d*<sup>1</sup>. It is thus made endwise movable relative to the section below *d*<sup>2</sup>, for the purpose of bringing the tool in contact with the stone, this adjustment being regulated by a screw, *h*, passing upward, through a longitudinal slot, *h'*, in section *d*<sup>2</sup>, into section *d*<sup>1</sup>. The section *d*<sup>1</sup> has upon its top a transverse dovetail tongue, *l*, that is received in a groove, *l'*, of corresponding shape on the under side of the section *d*. This construction allows the rest lateral adjustment, that is controlled by means of a screw, *m*, passing downward, through a transverse slot, *n*, in the section *d*, into section *d*<sup>1</sup>. At the end of the section *d* next the stone is a raised bridge, J, under which the tools are passed, being clamped against the rest by the screws *p*, one or more for each tool, passing through the said bridge and bearing upon the tool.

The lateral adjustment of the section *d* allows the tool to be passed back and forth across the face of the grindstone, thereby preventing the latter from being unevenly cut away. At each side of the rest-section *d* is a guide, T, pivoted at *o* thereto, and provided with a curved slot, *s*, and an adjusting-screw, *s'*, passing through the said slot into the said section. These guides are for the purpose of giving a regular and exact transverse shear to the edge of the dies and knives. The grindstone has upon one edge a bead, *t*, which cuts

the score in the end of the die turned thereon. At the outer end of the slide D is an adjusting-screw, N, which raises or lowers the rest, for the purpose of increasing or diminishing the bevel of the tool-edge.

What I claim as new, and desire to secure by Letters Patent, is—

1. The tool-rest G, consisting of the sections  $d$   $d^1$   $d^2$   $d^3$ , the section  $d$  being laterally movable relative to section  $d^1$ , the section  $d^1$  endwise movable relative to section  $d^2$ , and the section  $d^2$  horizontally vibratory relative to section  $d^3$ , which is vertically vibratory and supports the other sections, substantially as specified.

2. The grindstone A, having a bead,  $t$ , turned in its edge to form the score in the die, as and for the purpose specified.

3. In combination with the rest G, having the raised bridge J with clamp-screws  $p$ , the horizontally vibrating and adjustable guides T, substantially as specified.

In testimony that I claim the above I have hereunto subscribed my name in the presence of two witnesses.

LEWIS PATTERSON.

Witnesses:

J. R. BACKUS,  
JAMES CHADWICK.