

H. F. READ.
Wrench Attachment.

No. 203,774.

Patented May 14, 1878.

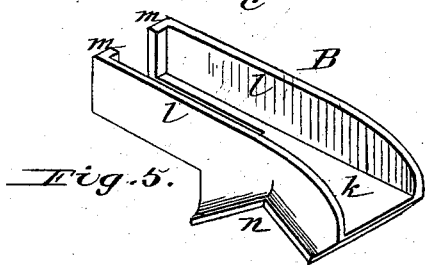
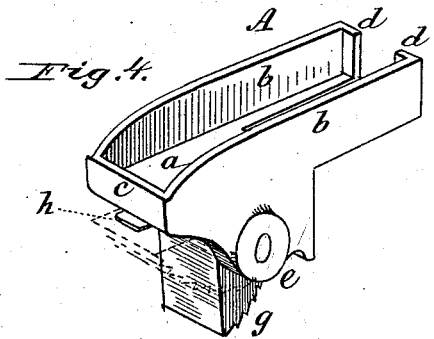
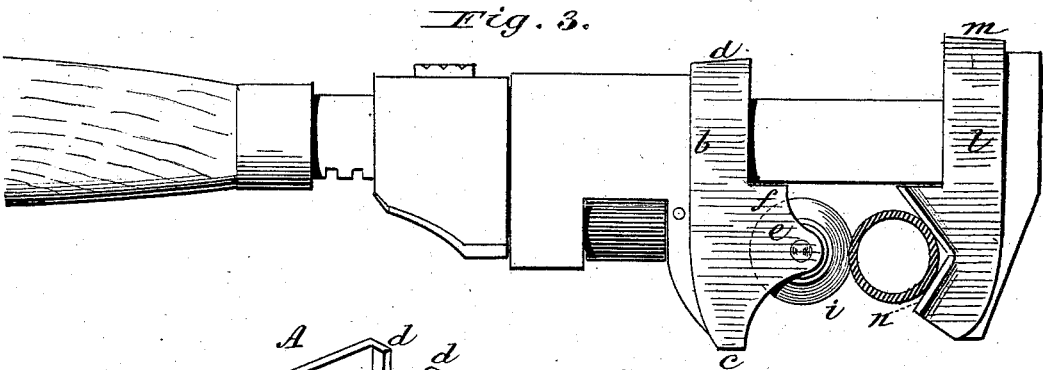
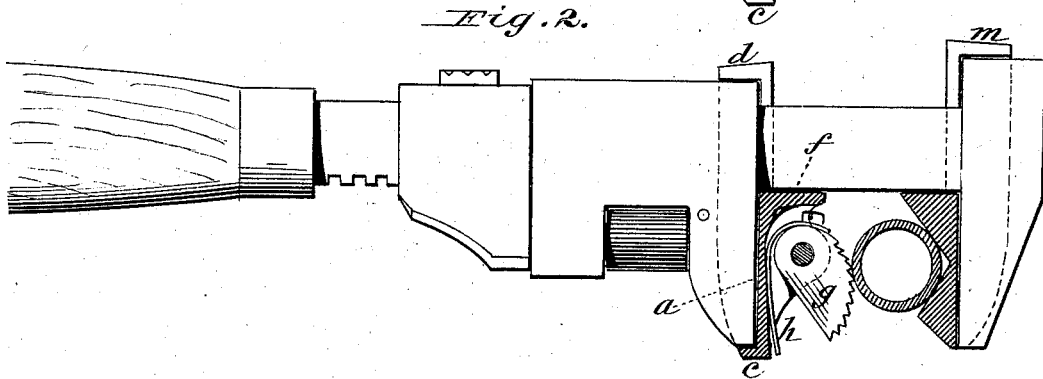
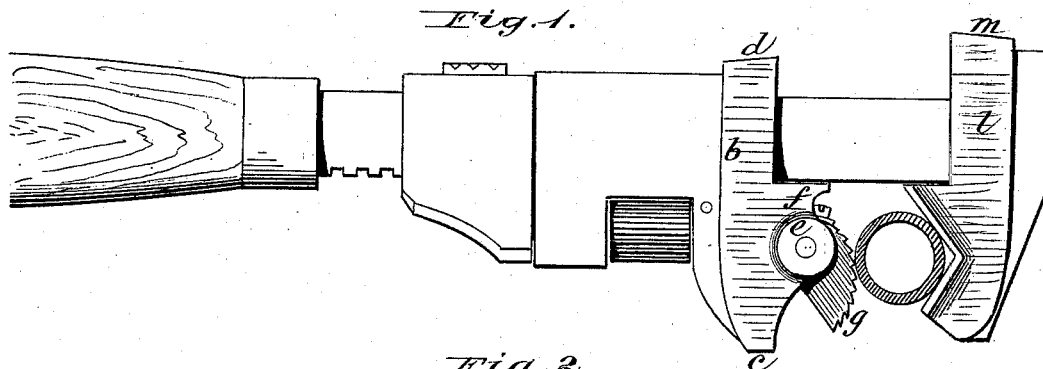

Attest:
H. D. Perrine
Floyd Harris

Inventor:
Henry F. Read
By Johnson & Johnson
Attys

UNITED STATES PATENT OFFICE.

HENRY F. READ, OF BROOKLYN, NEW YORK.

IMPROVEMENT IN WRENCH ATTACHMENTS.

Specification forming part of Letters Patent No. 203,774, dated May 14, 1878; application filed February 16, 1878.

To all whom it may concern:

Be it known that I, HENRY F. READ, of Brooklyn, in the county of Kings and State of New York, have invented certain new and useful Improvements in Wrench Attachments; and I do hereby declare that the following is a full, clear, and exact description thereof, which will enable others skilled in the art to which it appertains to make and use the same, reference being had to the accompanying drawings, and to letters of reference marked thereon, which form a part of this specification.

My object is to provide the ordinary sliding-jaw or monkey wrench with attachments by which it may be adapted as a pipe-tongs or for cutting pipe.

My improvements relate more particularly to the construction of such attachments as regards their connection with the jaw or jaws of the wrench, as will be more particularly pointed out hereinafter.

Referring to the drawings, Figure 1 represents an elevation of a monkey-wrench, showing attachments adapting it as a pipe-tongs; Fig. 2, a similar view of the same, the attachments being in section; Fig. 3, an elevation, showing the wrench adapted as a pipe-cutter; Fig. 4, a detail of the pipe-tongs attachment; Fig. 5, a detail of an attachment for the fixed jaw used for the purpose of centering the pipe.

As stated, my improvements refer to the monkey-wrench having the usual fixed and sliding jaws. The wrench shown is like that patented to me May 13, 1873; but my attachments may be applied to any analogous form of wrench.

The basis of the attachment device is a shoe or runner plate which grasps the jaw. This shoe-plate A is of peculiar construction, being a single casting, having a face or bearing plate, *a*, to fit against the face of the movable jaw, and from which plate sides *b b* project, of suitable depth to embrace the sides of said jaw, and of a length equal therewith. The ends of these sides terminating at the nose of the jaw are united by a cross-rim or nose-piece, *c*, while the opposite ends do not connect, but form short return-holds *d d*, which grasp the back of the jaw, and, with the nose and the sides, form the seating-hold, by which the at-

tachment is quickly and easily applied to the jaw. These grasping parts form a socket fitting tightly over the jaw, and require no other fastening than the friction of the parts, which is sufficient to hold the attachment in place in handling the wrench and in adjusting the movable jaw forward or back by the usual thumb-adjusting device. From the face or bearing plate *a* extensions of the sides *b b* project, and form bearings *e e* for the axis of the gripping-block or the cutter, and these extensions join in a cross-seat, *f*, fitting against the inner side of the fixed jaw-bar.

In the attachment for pipe-tongs the toothed gripping-block *g*, which has a segmental form, carries a plate-spring, *h*, at its pivoted end, which, curving under its hub, lies and bears against the outer side of the face or bearing plate, the attachment being applied so as to exert its force in holding the toothed gripping-block in its normal position toward the fixed jaw. This arrangement of the spring and pipe-gripping block allows the spring to turn and wind upon the hub against the face or bearing plate *a* when opened or turned outward in applying the wrench to the pipe, and to throw said block in and gripe the pipe by the tension of the spring, as shown in Fig. 2.

By means of the shoe or runner plate A, having the construction and grasping function described, the tendency of the attachment otherwise to bind upon the fixed jaw-bar is avoided, for the shoe-plate carrier for the gripe or cutter being so set or applied, as described by me, becomes an integral part, as it were, of the movable jaw, and has the same relations to the fixed jaw-bar as the movable jaw itself, the adjusting of the jaw effecting the same adjustment of the shoe-runner plate in either direction.

In adapting the wrench for cutting pipe or round bars a similar attachment is used, carrying, however, a circular cutter, *i*, the hub and bearing of which are in similar side extensions, and the device is operated as is usual with pipe-cutters.

As auxiliary to the movable jaw attachments, I purpose using a shoe attachment, B, for the inner side of the fixed jaw, consisting of face or bearing plate *k*, sides *l*, and return ends *m m*, and having an angular center-

ing rest or face, *n*, for centering and holding the pipe while under operation. This supplemental device is not absolutely necessary, but affords greater security in holding the pipe or rod while being cut, and, like the attachments previously described, depends for its security upon its close-fitting or frictional contact with the jaw.

It will be seen that by means of the attachments described the common monkey-wrench can be adapted for use as a pipe-tongs or pipe-cutter, while at the same time its usefulness merely as a wrench remains intact when the attachments are taken off.

In using the cutting attachment it is necessary to feed up the cutter as the cutting progresses; and as this requires more force than can be applied with the fingers, I propose to make the usual thumb-nut or feeding device with deep corrugations or teeth, adapted for use with a claw-wrench, so as to give the required force to the feed. The attachment is

applied by slipping it onto the jaw to embrace it.

I claim—

1. A wrench attachment consisting of a shoe or runner plate, *A*, having a face or bearing plate, *a*, sides *b b*, a nose-piece, *c*, and return-end holds *d d*, being a single casting, and adapted to be secured to the movable jaw of a wrench, and to carry pipe-cutting or griping devices.

2. The shoe *A*, having the pivoted griping device, in combination with the spring *h*, attached to and carried by the hub of said griping-block, and traveling upon the bearing-plate *a*, as described.

In testimony that I claim the foregoing I have affixed my signature in the presence of two witnesses.

HENRY F. READ.

Witnesses:

A. E. H. JOHNSON,

J. W. HAMILTON JOHNSON.