

L. STERNBERGER.  
Treadle Apparatus for Applying Power to Sewing-  
Machine.

No. 203,791.

Patented May 14, 1878.

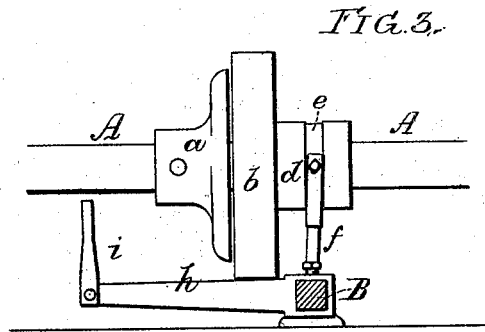
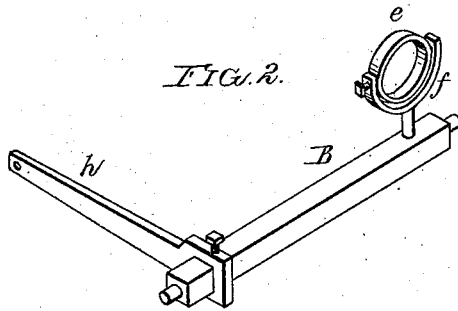
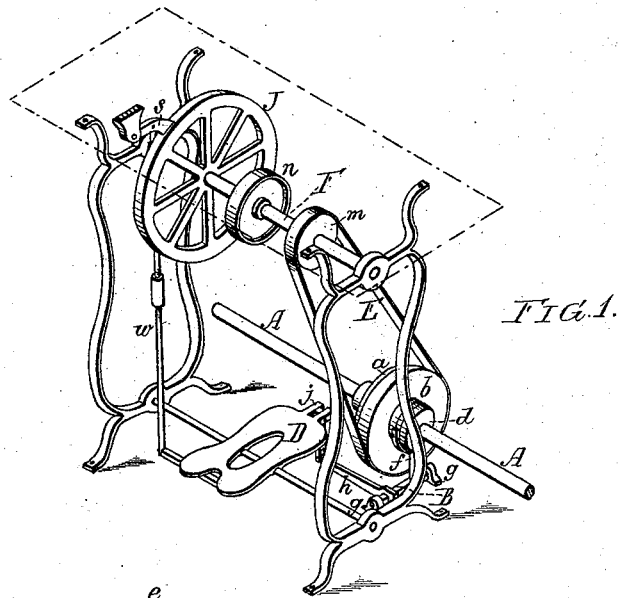

Witnesses,  
Harry Smith  
Henry Howson, Jr.

Inventor  
Seipold Sternberger  
by his Attorneys  
Howson and Son

# UNITED STATES PATENT OFFICE.

LEOPOLD STERNBERGER, OF PHILADELPHIA, PENNSYLVANIA.

IMPROVEMENT IN TREADLE APPARATUS FOR APPLYING POWER TO SEWING-MACHINES.

Specification forming part of Letters Patent No. **203,791**, dated May 14, 1878; application filed April 22, 1878.

*To all whom it may concern:*

Be it known that I, LEOPOLD STERNBERGER, of Philadelphia, Pennsylvania, have invented a new and useful Improvement in Power-Driven Sewing-Machines, of which the following is a specification:

The object of my invention is to construct and apply to a sewing-machine mechanism for driving the same by power in such a manner that the parts of the sewing-machine need not be altered in any respect—an object which I attain in the following manner, reference being had to the accompanying drawing, in which—

Figure 1 is a perspective view illustrating the mode of carrying out my invention, and Figs. 2 and 3 detached views of parts of the same.

A is a longitudinal power-driven shaft, arranged preferably between two parallel rows of sewing-machines which are to be driven by said shaft. On this shaft, adjacent to each machine, is secured a collar, *a*, and on the shaft adjacent to this collar is arranged to slide a loose disk, *b*, faced with leather, cork, or similar material, and having a projection, *d*, to a groove, in which is adapted a ring, *e*, carried by a forked arm, *f*, which projects from one end of a rock-shaft, B, the latter being adapted to bearings *g* on the floor, and having at or near its opposite end an arm, *h*, connected at the outer end by means of a link, *i*, with the slotted projection *j*, with which the front end of the treadle D is provided, and to which the lower end of the pitman is usually connected.

It will be seen that the collar *a* forms a clutch, by which the disk *b* may be caused to revolve with the shaft, or may be freed from the same, as desired.

The arm *h* is adjustable laterally on the rock-shaft B, so that it may be set to accord with the position of the machine in respect to the shaft A, this position varying, owing to the fact that the tables of some machines are wider than those of others, so that, when the edges of the tables of one row of machines are brought into contact with the edges of the

tables of the adjacent row, (which position is desirable on account of compactness,) the treadles of the machines are at different distances from the shaft A.

A belt, E, passes round the disk *b* and round a pulley, *m*, on the usual driving-shaft F of the machine, a second pulley, *n*, on this shaft serving to impart movement to the shaft of the machine above the table, the latter, in the present instance, being shown by dotted lines.

To a bearing on the under side of the table, in line with the fly-wheel J, is hung a brake, *s*, which is connected with the inner end of the treadle D by means of an arm, *w*, the latter, by preference, being so constructed that it can be readily shortened, so as to compensate for the loss caused by the wearing of the brake *s*.

The operation of the devices is as follows: When it is desired to start the machine the outer end of the treadle D is depressed, so as to operate the rock-shaft B and throw the disk *b* into frictional contact with the collar *a*, the rotary motion of which is thus imparted to the disk, and by it to the shaft F. The same movement of the treadle which effected this operation raised the brake *s* from the surface of the wheel J, so that the latter was free to revolve.

A reverse movement of the treadle D withdraws the disk *b* from contact with the collar *a* and causes the brake to be brought into contact with the periphery of the wheel J, so as to effect the instant stoppage of the machine.

I wish it to be understood that I do not desire to claim, broadly, the starting and stopping of the machine and the application of the brake by means of a movement of the treadle, as I am aware that various combinations of devices have been hitherto employed by which this result has been accomplished. Therefore

I claim as my invention—

1. The combination of sewing-machine shaft F, having pulleys *m* and *n* and fly-wheel J, the driving-shaft A, having the fixed collar

*a* and loose disk *b*, the rock-shaft B, having arms *f* and *h*, the treadle D, the brake *s*, and the rod *w*, all constructed, arranged, and operating substantially as and for the purpose herein set forth.

2. The combination of the shaft A, its collar *a* and disk *b*, the treadle D, and the rock-shaft B, with its forked arm *f* and adjustable arm *h*, as set forth.

In testimony whereof I have signed my name to this specification in the presence of two subscribing witnesses.

LEOPOLD STERNBERGER.

Witnesses:

HARRY A. CRAWFORD,  
HARRY SMITH.