

T. TREZISE.

Apparatus for Hermetically-Sealing Can.

No. 203,796.

Patented May 14, 1878.

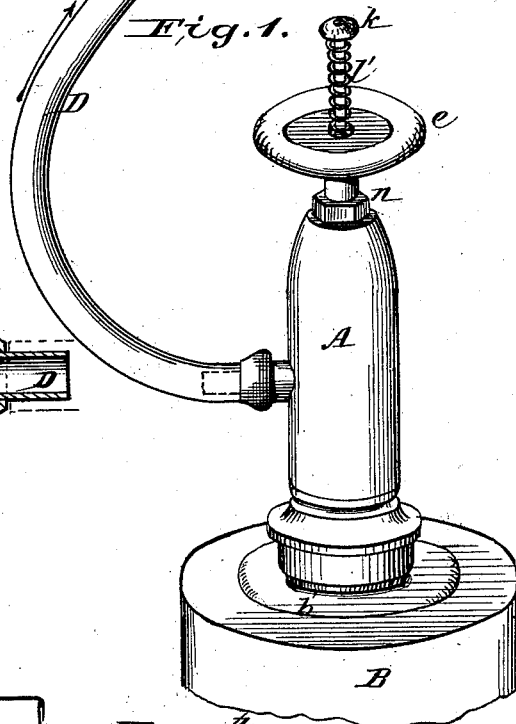
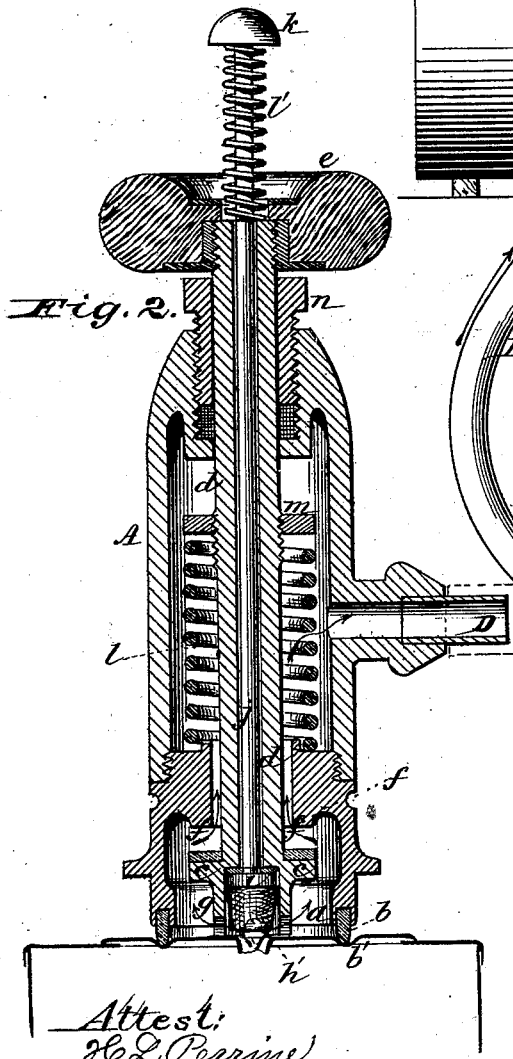
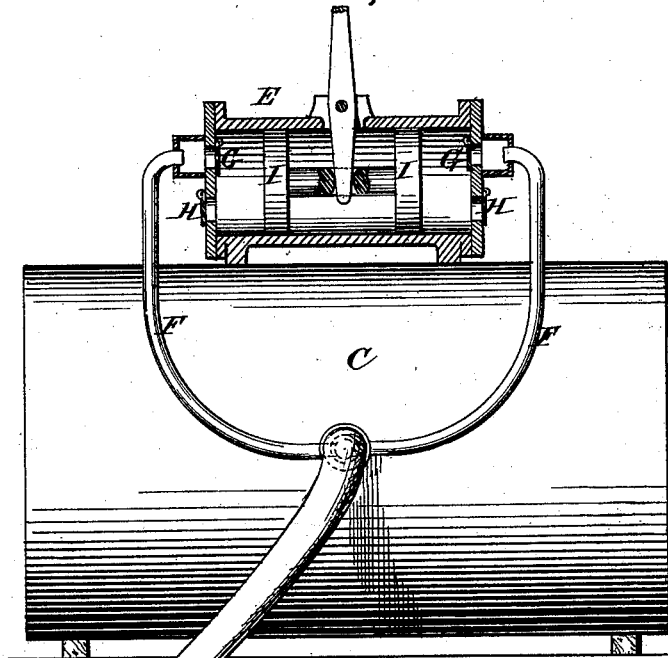

Attest:  
*H. L. Perrine*  
*Floyd Harris.*

Inventor.  
*Thomas Trezise*  
 By *Johnson and Johnson* Attys.

T. TREZISE.

Apparatus for Hermetically-Sealing Can.

No. 203,796.

Patented May 14, 1878

Fig. 3.

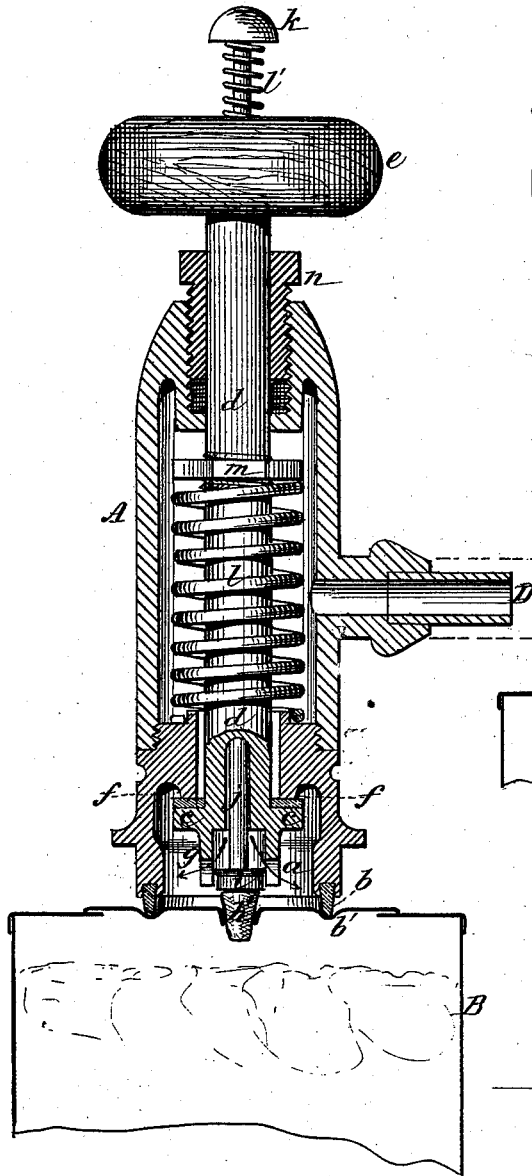

Fig. 4.

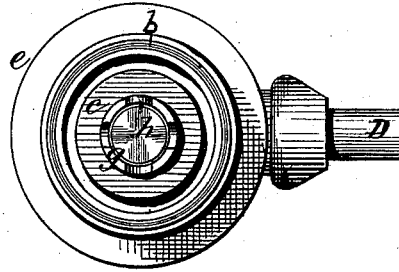

Fig. 5.

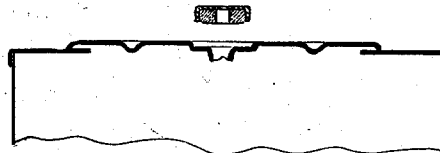
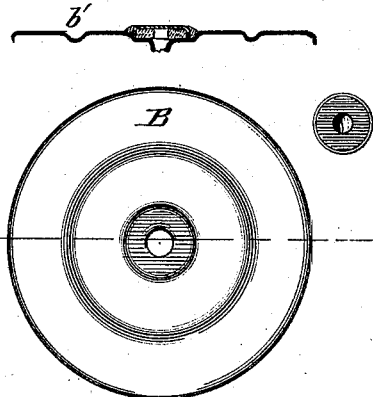

Fig. 6.



Attest:  
 W. D. Perrine,  
 Floyd Harris

Inventor,  
 Thomas Trezise  
 By: Johnson & Johnson  
 Attys.

# UNITED STATES PATENT OFFICE.

THOMAS TREZISE, OF BALTIMORE, ASSIGNOR OF TWO-THIRDS HIS RIGHT TO JESSE GILLMORE, OF SAME PLACE, AND GEORGE W. COFRAN, OF MOUNT WINANS, MARYLAND.

## IMPROVEMENT IN APPARATUS FOR HERMETICALLY SEALING CANS.

Specification forming part of Letters Patent No. **203,796**, dated May 14, 1878; application filed April 25, 1878.

### *To all whom it may concern:*

Be it known that I, THOMAS TREZISE, of Baltimore city and State of Maryland, have invented certain new and useful Improvements in Apparatus for Hermetically Sealing Cans; and I do hereby declare that the following is a full, clear, and exact description thereof, which will enable others skilled in the art to which it appertains to make and use the same, reference being had to the accompanying drawings, and to letters of reference marked thereon, which form a part of this specification.

In packing fruit and food holding vessels the air is exhausted therefrom, and the small opening in the vessel is then sealed to preserve the articles in their natural state. Various plans have been devised for effecting this sealing operation under vacuum, in which ordinary vacuum-pumps have been used to exhaust the air by the direct application and operation of the pump in connection with the vessel and a sealing device.

My improvements involve a perpetual vacuum-chamber, with which a double-acting vacuum-pump or ejector is combined, in connection with one or more valved sealing devices having constant communication with the vacuum-chamber and adapted to put the interior of the vessel in such communication when the valved sealer is in position to apply the sealing plug or cap. The vacuum-chamber and the sealing device are connected by a flexible tube, and the double-acting vacuum-pump is connected by pipes leading from the ends thereof to the junction of the flexible tube with said reservoir.

The hand sealing device proper has an open chamber at its lower end, provided with a rubber sealing-ring, to surround and seal the can-opening from the outside air when applied to the top of the can, and within this chamber a vertically-acting valved holder for the sealing plug or cap is arranged to put the interior of the can in direct communication with the vacuum-chamber, and at the same time to apply said plug or cap to the can-opening. A vertically-acting valved plug-driver is arranged to operate within the stem of the valved

plug-holder to drive the plug or bed a sealing-cap at the proper time, and to serve also to relieve the sealer from the can by admitting air to the bottom chamber to equalize the atmospheric pressure therein.

The valved plug-holder and the plug-driver have independent movement within the hand holder or case, which is applied over the opening in the can and held thereon during the operating of sealing it.

Referring to the drawings, Figure 1 represents a view, in perspective, of a sealing apparatus for packing fruit and food in their natural state in sealed vessels; Fig. 2, a vertical section of the sealing device proper, showing the communication of the vacuum-reservoir with the can open and the plug in position to be driven; Fig. 3, a similar section, showing the plug driven and the vacuum communication cut off; Fig. 4, a bottom view of the sealing device; and Figs. 5 and 6 show the sealing-cap.

The apparatus consists, primarily, of a valved sealing device proper, A, applied to the top of the can B by hand, and a perpetual fixed vacuum-chamber, C, connected with one or more sealing devices by flexible tubes D, whereby a number of separate sealers can be used, or a single sealer can be applied to a number of cans in succession as the air is exhausted and each one sealed.

The apparatus is used upon a suitable bench, upon which the vacuum-vessel is secured, which consists of a metallic tank, C, of suitable size, and connected with a double-acting vacuum-pump, E, preferably arranged upon said tank, as shown. The flexible tube has a direct connection with this vacuum-tank and the body of the sealing device, while the double-acting air-pump connects by outside pipes F F, leading from each valved end to the junction of the flexible tube, with the tank, so as to avoid separate openings therein for these pipes.

The pump has an inside and an outside valve, G H, at each end, and a double piston, I, operating to open and close these valves alternately, so as to pump the air from the tank, and thereby create and maintain a perpetual

vacuum therein, so that when the exhauster and sealer is applied to the can and the plug-holding valve opened the air from the can will be at once exhausted into the vacuum-tank, so that the latter becomes a perpetual exhauster for the volatile contents of the can at the moment the communication between the two is made, as shown in Fig. 2.

The pump is operated by any suitable connections made therewith between the pistons through the cylinder.

The sealing device is a case adapted to be held by hand, with its lower end provided with a space or chamber, *a*, and a bottom-sealing gasket, *b*, adapted to fit into an annular groove, *b'*, in the can-top, around the center opening, to make a sealing-contact to exclude the outer air from the can, and to center the plug with the top opening. Within the bottom chamber of this case is arranged a vertically-acting valve, *c*, carried by a hollow guide-stem, *d*, which extends above the case *A*, and has a pressure-head, *e*, by which it is depressed by hand to open the valve from its seat *f*, and put the interior of the can in communication with the vacuum-tank by the flexible tube which connects with a nozzle on the case *A* above said valve. This valve has a central tubular projection, *g*, extending down a sufficient distance to form a holding-socket, *h*, for the sealing-plug *h'*, which, by the act of opening the valve *c*, is placed in the can-opening, into which it is driven by the descent of a valved driver, *i*, as in Fig. 3, arranged within the hollow valve-stem *d*, and carried by a stem, *j*, extending above it, with a pressure-knob, *k*, on its end, by which it is forced down by hand at the proper time.

The plug-driver *i* has a gasket, which closes upon a seat in the valve *c* above the plug-holding socket, to prevent the entrance of air into the bottom chamber *a* when the valve *c* is opened, but which allows the entrance of air into the foot-chamber *a* to equalize the pressure therein after the valve *c* is closed to allow the sealer to be removed from the can.

The valve *c* is retracted by a coil-spring, *l*, bearing upon a shoulder in the case, and an adjustable nut, *m*, on the hollow valve-stem, while the plug-driver is retracted by a coil-spring, *l'*, bearing upon the top of the hollow valve-stem and against the knob *k* of the plug-driver stem.

A stuffing-box, *n*, at the top of the case *A* seals the hollow valve-stem, to prevent the air from entering the bottom chamber *a* when the valve *c* is opened. The case *A* is in sections, so as to be taken apart to renew the packing and to adjust the tension of the spring, as may be required.

I use a rubber plug, or a cap with a rubber gasket, which I insert in the valve-holding socket *h* before the sealer is applied to the can, and the moment the valve *c* is forced

down the air is exhausted from the can into the vacuum-chamber, and the same movement places the plug or cap; and, following this quickly, the driver is forced down by a sudden blow and inserts the plug, the valve *c* having in the meantime been released and closed, to shut off the communication with the vacuum-tank. The plug-inserting blow of the driver *i* admits air through the hollow valve-stem, to allow of the removal of the sealer. Both of these valves are provided with suitable packing to render them air-tight. By having a perpetual fixed vacuum-chamber, a number of sealers can be used at the same time by having independent flexible connections with said vacuum-tank.

The rubber plug, when driven, fastens and seals itself in the hole of the can.

Instead of a plug adapted to be driven, I may use a capped gasket, and bed it over the can-opening by the valve-holding socket, and release it therefrom by the descent of the driver. In this case the can-top has an annular recess to receive the capped gasket, which is applied just after the air has been exhausted from the can, and is held in place by the pressure of the outer air, and it is soldered when the sealer is removed, as shown in Figs. 5 and 6.

The vacuum-chamber may be used in connection with vacuum-pipes, and a gage is connected therewith to indicate the proper vacuum required for efficient operation with one or more cans at the same time.

Instead of the vacuum-pump, I may use an ejector similar to those employed in vacuum-brakes for cars, and I think an ejector will give the best results in producing and maintaining an effective vacuum.

The plug-holding socket *g h* has notches around its open end, to allow the air to pass out of it from the can in case said valve-socket should rest upon the can when the valve is open, as shown in Fig. 2.

I claim—

1. For sealing fruit and food holding vessels, a perpetual vacuum-chamber, in combination with a sealer having a flexible connection with said perpetual vacuum-tank, a valve to open and close communication therewith and to hold the plug or sealing-cap for the can, and a valved driver to drive the plug into the can-opening or deposit the cap over said opening, to seal the can after the air has been exhausted therefrom, as and for the purpose specified.

2. A sealing device having a plug or cap holding valve arranged to open and close within a bottom chamber of said device, and below its point of connection with the perpetual vacuum-chamber, and a plug-driver or cap-layer arranged within the plug-holding valve, for operation in exhausting the air and sealing the can, substantially as specified.

3. A can-sealing device having a plug-driving valve arranged and operating within the hollow stem of a plug or cap carrying-valve, in combination with the foot-sealing gasket and a perpetual vacuum-chamber, with which said plug-carrying valve opens and closes communication.

In testimony that I claim the foregoing I have affixed my signature in the presence of two witnesses.

THOS. TREZISE.

Witnesses:

A. E. H. JOHNSON,  
J. W. HAMILTON JOHNSON.