

W. C. WILLIAMSON.  
Hoisting-Machine.

No. 203,808.

Patented May 14, 1878.

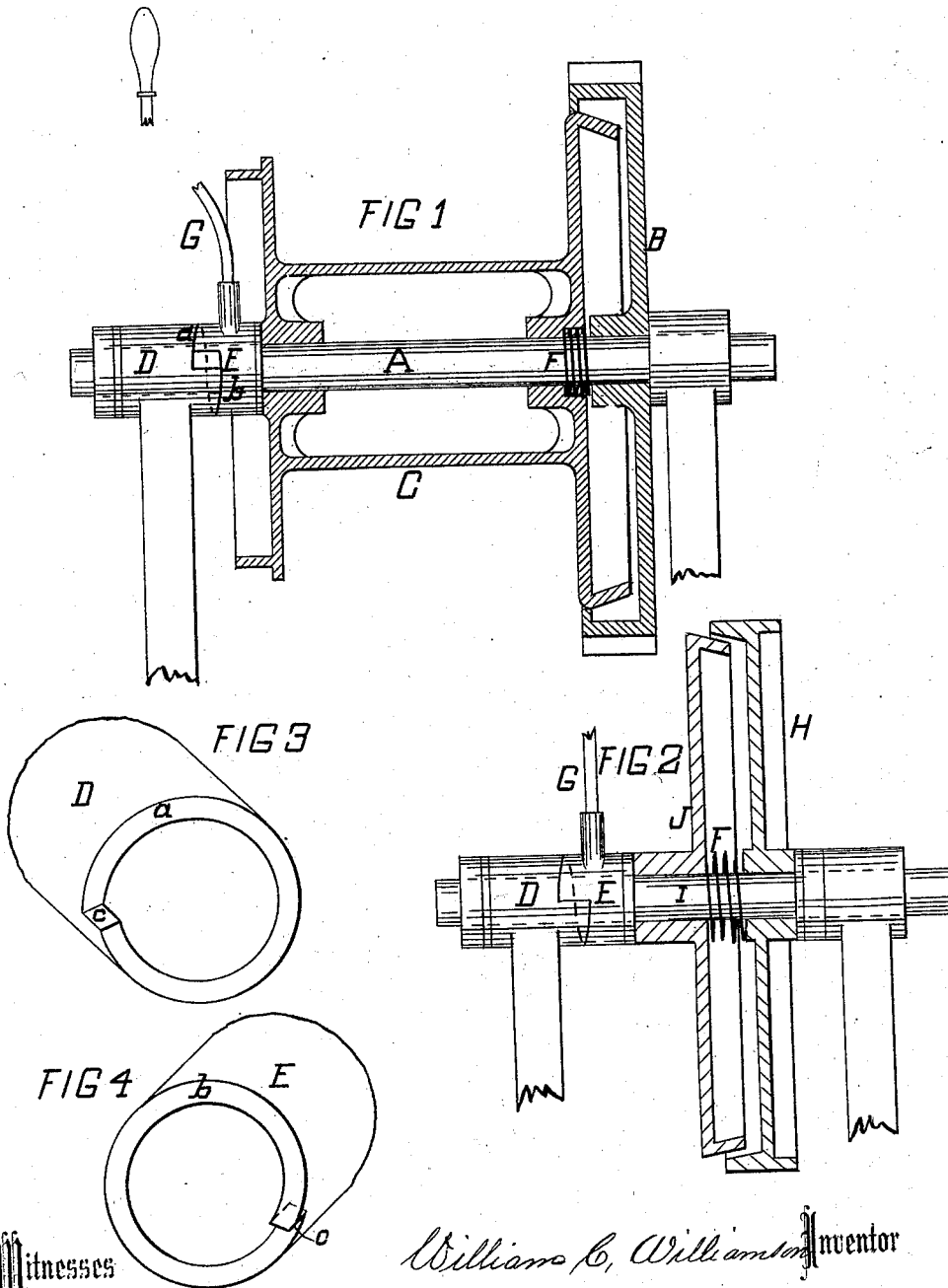

Witnesses  
Alex. J. Diamond  
Smallwood

By

William C. Williamson Inventor

Francis D. Pastorius

Attorney

# UNITED STATES PATENT OFFICE.

WILLIAM C. WILLIAMSON, OF PHILADELPHIA, PENNSYLVANIA, ASSIGNOR  
TO WILLIAMSON BROTHERS, OF SAME PLACE.

## IMPROVEMENT IN HOISTING-MACHINES.

Specification forming part of Letters Patent No. 203,808, dated May 14, 1878; application filed  
April 18, 1877.

*To all whom it may concern:*

Be it known that I, WILLIAM C. WILLIAMSON, of the city and county of Philadelphia, and State of Pennsylvania, have invented a new and useful Device for the Engagement and Disengagement of Machinery, of which the following is a specification:

The engagement and disengagement are effected by means of a fixed block and a loose block on the same shaft. The contact or acting faces of the blocks are spirally formed or inclined, to correspond and exactly fit one against the other.

Figure 1 is an end elevation of a hoisting-machine. The winding-drum and the frictional driving-wheel are shown engaged in section. The drum turns loosely and has a longitudinal motion on the shaft. The frictional driving-wheel turns with the shaft and is without longitudinal motion.

Fig. 2 is an end elevation of a friction-clutch. The clutch-wheel and the pulley are shown, disengaged, in section. The clutch-wheel moves on and turns with the shaft. The pulley turns loosely on the shaft.

Figs. 3 and 4 are views of the fixed and loose blocks, showing the spirally formed or curved inclined contact-faces.

A, Fig. 1, is the driving-shaft of a hoisting-machine in suitable bearings; B, the frictional driving-wheel, which turns with the shaft; and C, the winding-drum, capable of moving round and sliding on the shaft. D is a fixed box or collar, and E a loose box or collar, in both of which the shaft A turns. Their contact or acting faces *ab* are inclined or spirally formed so as to exactly fit one against the other, the advancing incline being in the direction which the drum C must slide to engage the wheel B. If necessary, a stop or offset, *c*, can be made in the contact-faces of the boxes or collars D E, for limiting the extent of the motion of the loose collar.

While the fixed box D is shown herein as a part of the housing, it may be fastened to any device which will hold it at the required point on the shaft.

F is a spiral or other suitable spring, placed between the hub of the driving-wheel B and the hub of the drum C.

The drum C and the driving-wheel B are engaged by turning the lever G in the direction of the advancing incline of the con-

tact-faces of the boxes, which causes the loose box E to slide forward and push the drum into contact with the wheel and partake of its motion. The disengagement is effected by turning the lever in the opposite direction, or that of the retreating incline of the contact-faces of the boxes, which relieves the drum of their pressure, and permits it to react and throw the drum and wheel apart, though they will often slide free of each other without the aid of the spring. The pitch of the spiral or inclined contact of the faces of the blocks must be sufficient for whatever space the drum C may have to slide on the shaft A in making its contact with the wheel B, in increasing the frictional contact regularly to any degree of pressure, and in communicating the motion without shock.

The engagement and disengagement devices D E can be applied to other mechanisms than that of a hoisting-machine. Fig. 2 shows it applied to a friction-clutch.

H is a clutch-pulley or gear-wheel, revolving freely on the shaft I, with which it is required occasionally to be connected in order to give motion. J is a clutch or friction-contact wheel, which slides along and turns with the shaft I by means of a feather or key. F is a spring, and D E the fixed and loose boxes.

I have illustrated and described my invention, the engagement and disengagement boxes D E, in connection with a hoisting-machine and a friction-clutch. I wish it distinctly understood that I do not confine the invention to its connection with those machines, but claim it generally in its application for the engagement and disengagement of machinery.

I claim as my invention—

In a hoisting-machine, the fixed box or collar D forming a part of the frame of the machine and having a spirally-formed face, as described, and the loose collar E provided with a correspondingly-formed face and the lever G, combined with the shaft-carrying frictional hoisting-gear, and the spring F, substantially as specified.

In testimony whereof I hereunto sign my name in presence of two subscribing witnesses.

WILLIAM C. WILLIAMSON.

Witnesses:

FRANCIS D. PASTORIUS,  
ALEXANDER J. DIAMOND.