

L. L. HANSEN.
Barrels.

No. 203,824.

Patented May 21, 1878.

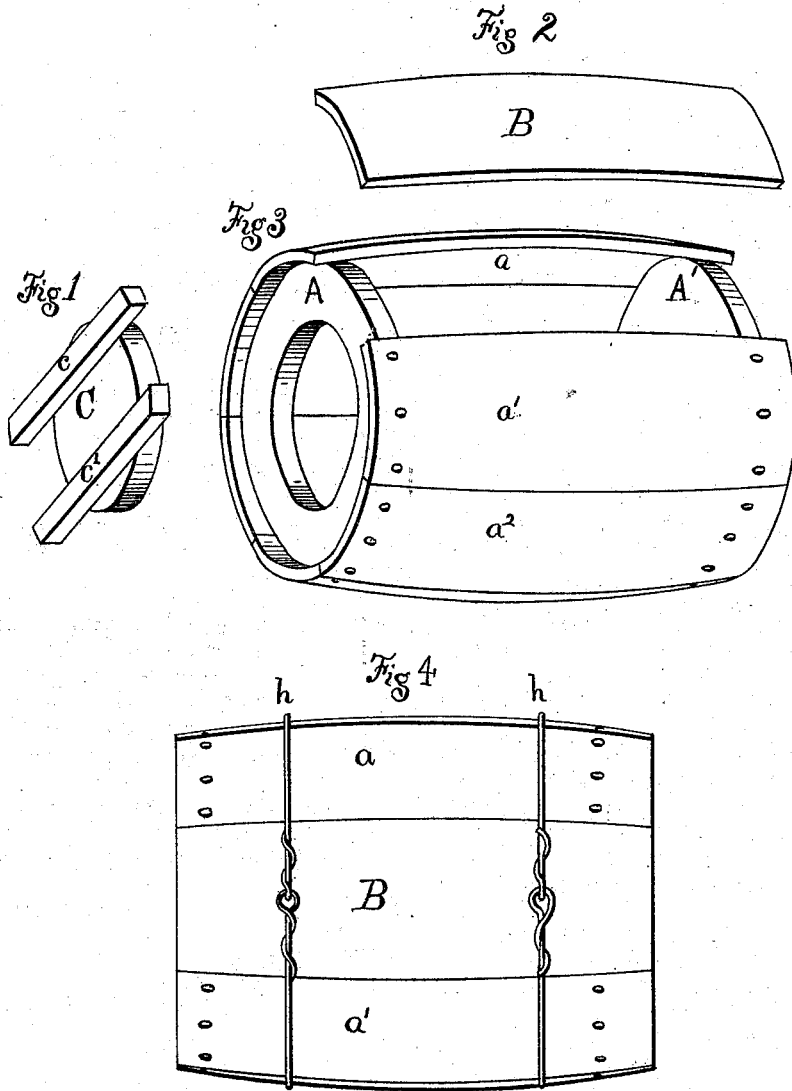

Witnesses:
Henry A. Bulver,
W. G. Derrick.

Inventor:
L. L. Hansen,
per P. S. Reid,
attly.

UNITED STATES PATENT OFFICE.

LADLEY L. HANSEN, OF PALMYRA, NEW YORK.

IMPROVEMENT IN BARRELS.

Specification forming part of Letters Patent No. **203,824**, dated May 21, 1878; application filed December 26, 1877.

To all whom it may concern:

Be it known that I, LADLEY L. HANSEN, of Palmyra, in the county of Wayne and State of New York, have invented a new and useful Improvement in Barrels, which improvement is fully set forth in the following specification, reference being had to the accompanying drawings.

The object of my invention is to make a strong, cheap, and convenient barrel in which to pack and ship fruits, flour, salt, nails, and the like.

Figures 1, 2, and 3 are perspective views of a loose head and stave, and of the barrel with head and stave removed. Fig. 4 is a view of the barrel put together and with the hoops on.

The staves *a a' a²* are nailed to the heads *A A'*, which are made solid. The stave *B* is loose, so as to pack the barrel from the side, and also to facilitate inspection of the contents of the barrel.

The head *C*, which is smaller than, and fits into, the head *A*, can be removed, so as to fill and inspect from the end, and is held in its place by nailing the strips *c c'* to the head *A*.

After the barrel has been filled from the side the loose stave is replaced, and the wire hoops *h h* are put on and driven to their places. To prevent the hoops from coming off they should be struck smartly in two or three places with a hammer, which will drive them into the staves, and thus make it unnecessary to nail them.

The wire hoops *h h*, it will be seen, can be quickly made by first looping one end; then insert the other end into the loop, pass it over the barrel, and when near its place bend the end back, remove from the barrel, and twist the end around the hoop, insuring correct length.

I claim as my invention—

The barrel made substantially as described, with the staves nailed to the heads, in combination with the loose head *C* and stave *B*.

L. L. HANSEN.

Witnesses:

L. H. TIFFANY,
GEO. THROOP.