

M. A. ANDREWS.  
Draft-Equalizer.

No. 203,871.

Patented May 21, 1878.

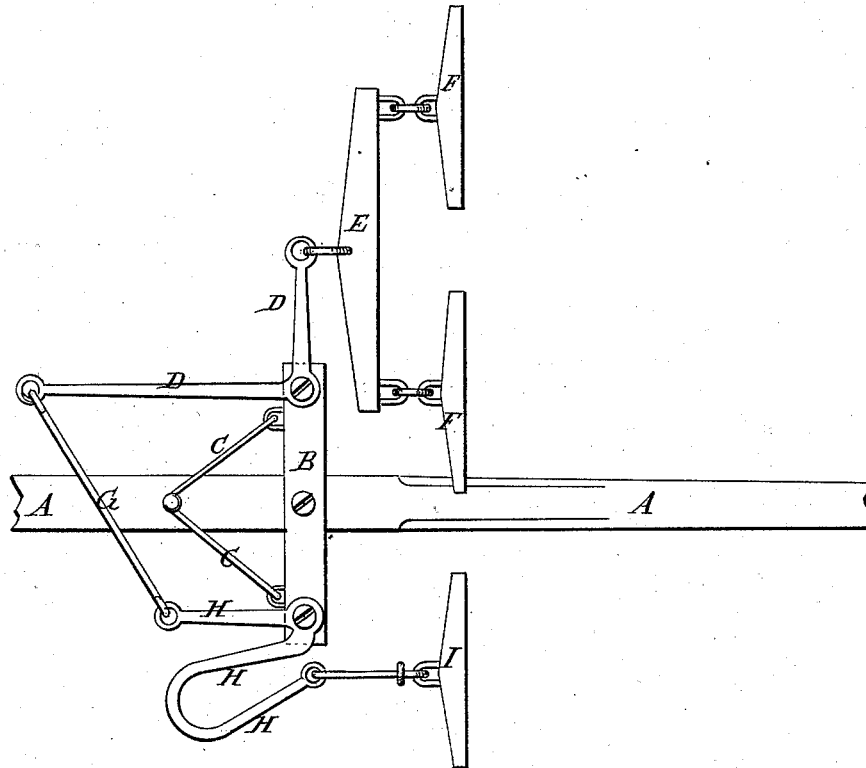

WITNESSES:

*Cmas. Nida.*  
*C. Serquick*

INVENTOR:

*M. A. Andrews*

BY

*Mumford*

ATTORNEYS.

# UNITED STATES PATENT OFFICE.

MATHEW A. ANDREWS, OF WILLSBURG, IOWA.

## IMPROVEMENT IN DRAFT-EQUALIZERS.

Specification forming part of Letters Patent No. **203,871**, dated May 21, 1878; application filed February 16, 1878.

*To all whom it may concern:*

Be it known that I, MATHEW ALLEN ANDREWS, of Willsburg, in the county of Page and State of Iowa, have invented a new and useful Improvement in Three-Horse Draft-Equalizers, of which the following is a specification:

The figure is a top view of my improved equalizer.

The object of this invention is to furnish an improved device for equalizing the draft when three horses are used abreast, which shall be simple in construction and effective in operation.

The invention consists in the combination of the stationary cross-bar, the stay-rods or braces, the right-angled lever, the connecting-rod, and the bent lever, having its outer arm curved into U form, with each other and with the draw-bar, as hereinafter fully described.

A represents a tongue, plow-beam, or other draw-bar, to which is bolted a short cross-bar, B, which is held stationary by stay-rods C, attached to the draw-bar A, in the rear of the said cross-bar B.

D is a right-angled lever, which is pivoted at its angle to one end of the cross-bar B. The short arm of the lever D projects in line with the cross-bar B, and to its end is attached the

double-tree E, having the whiffletrees F of the two horses attached to its ends. The long arm of the bent lever D projects to the rearward, and to its end is pivoted the end of the connecting-rod G, the other end of which is pivoted to the end of the rear arm of the bent lever H. The lever H is pivoted at its angle to the end of the cross-bar B, and its rear arm is half the length of the rear arm of the bent lever D. The other arm of the lever H is about twice the length of the outer arm of the lever D, and is bent into U form, so that its outer end may be close to its angle. The whiffletree I of the single horse is attached to the outer end of the lever H.

Having thus described my invention, I claim as new and desire to secure by Letters Patent—

The combination of the stationary cross-bar B, the stay-rods or braces C, the right-angled lever D, the connecting-rod G, and the bent lever H, having its outer arm curved into U form, with each other and with the draw-bar A, substantially as herein shown and described.

MATHEW ALLEN ANDREWS.

Witnesses:

GEO. E. MORRILL,  
ISABEL MORRILL.