

J. H. HOBART & C. W. STWARD.
Amalgamator.

No. 203,916.

Patented May 21, 1878.

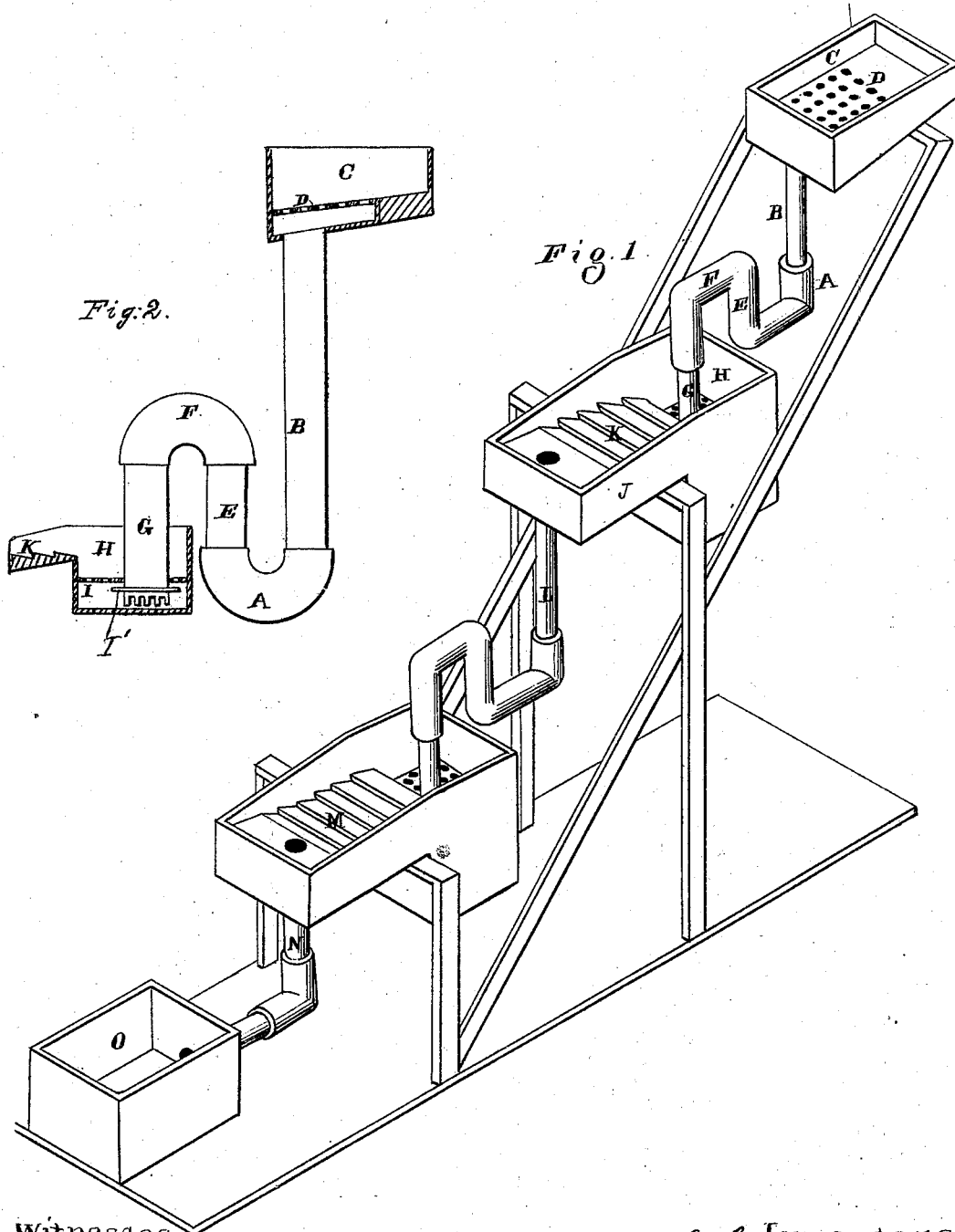

Witnesses

Geo. H. Strong
Frank A. Brooks

Inventors
John H. Hobart and
Charles W. Stward
by *Dewey & Co.*
Attys

UNITED STATES PATENT OFFICE.

JOHN H. HOBART AND CHARLES W. STWARD, OF OAKLAND, CALIFORNIA.

IMPROVEMENT IN AMALGAMATORS.

Specification forming part of Letters Patent No. 203,916, dated May 21, 1878; application filed April 4, 1878.

To all whom it may concern:

Be it known that we, JOHN H. HOBART and CHARLES W. STWARD, of Oakland, county of Alameda and State of California, have invented an Improved Amalgamator; and we do hereby declare the following to be a full, clear, and exact description thereof, reference being had to the accompanying drawings.

Our invention relates to certain improvements in that class of amalgamators in which the pulverized ore, black sand, tailings, or other material containing valuable metals is carried into and beneath a body of mercury; and it consists in the employment of a series of chambers containing mercury, into which the feed and connecting pipes dip, and through which the sand is forced to pass by gravitation, suitable distributors being employed, while between each pair of the series are placed sluices containing riffles, and the whole terminates in a tailing or settling box, as will be more fully described by reference to the accompanying drawings, in which—

Figure 1 is a perspective view of our apparatus, and Fig. 2 is a longitudinal section of the same.

A is a chamber containing mercury, which in the present case is shown as forming a reversed curve, in which the mercury stands above the inside of the bend. A feed-pipe, B, enters this chamber at one side, and extends up to a height sufficient to cause the gravitation of the sand to carry it through the body of mercury. A feed-box, C, brings the sand to the top of this pipe, and a screen, D, prevents all large rocks or gravel from entering. After passing through the chamber A the sand rises in the short pipe E, passing over the curve F, and thence down through the pipe G, the lower end of which opens close to the bottom of the box or chamber H.

The lower end of this pipe is notched or serrated all around, so as to facilitate the escape of the material in every direction and insure its thorough and complete distribution through the mercury contained in the chamber and surrounding the pipe. A fine screen, I, is placed across the chamber, just above the end of the pipe, and this insures a more complete breaking up of the sand, and it overcomes the

tendency of the mercury to crowd the sand together and lift it to the surface in a mass.

A flange, I', is fitted around the lower end of the pipe, so as to carry the sand well out from the pipe before it begins to rise, and thus insure a better distribution. After passing through the screen the sand rises to the surface, and passes out of the chamber H through the sluice J, which is inclined and provided with riffles K or amalgamated plates, over which the sand passes, and then falls into another pipe, L. This pipe leads to another arrangement or series of chambers and pipes, similar to A G H, through which the sand passes, and thence over a second riffle, M. From this riffle the sand passes down through a pipe, N, and into the settler or tailings-box O, where any light particles, mercury, or amalgam will be deposited, while the water and waste matter will overflow and be discharged.

In the present case we have shown but two series of chambers and riffles; but it will be seen that more might be added in event of necessity.

Having thus described our invention, we do not claim, broadly, the passing of auriferous earths through a body of mercury; but

What we do claim as new, and desire to secure by Letters Patent, is—

1. The hopper C, having screen D and feed-pipe B, arranged above and in combination with a mercury-chamber A, pipes E F G, and chamber, with a screen, I, whereby gravity forces the sand through the mercury into chamber H, as set forth.

2. The pipes B E and chambers A and H, in combination with the pipe G, serrated at the bottom, as shown, and provided with the distributing flange or plate I', substantially as shown, and for the purpose herein described.

3. The chambers A and H and the pipes B, E, and G, in combination with the riffles or plates K, substantially as herein described.

In witness whereof we hereunto set our hands.

JOHN H. HOBART.

CHS. W. STWARD.

Witnesses:

FRANK A. BROOKS,

M. A. NEAL.

750