

N. W. CONDUCT, Jr.  
Portable Railway.

No. 204,007.

Patented May 21, 1878.

Fig. 1

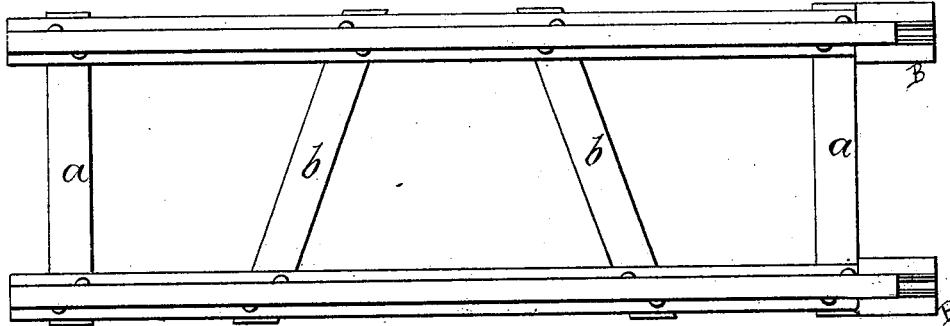

Fig. 2

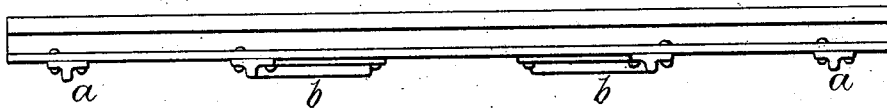

Fig. 3

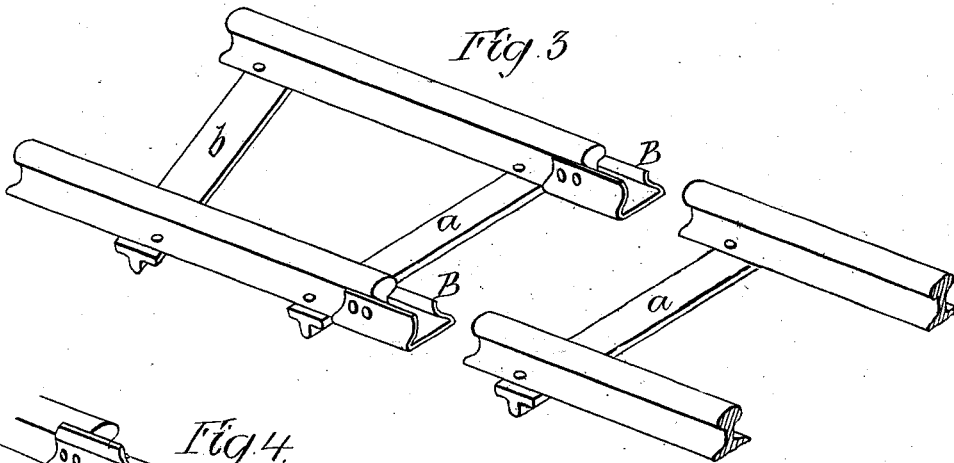

Fig. 4

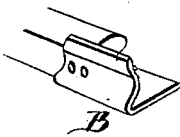
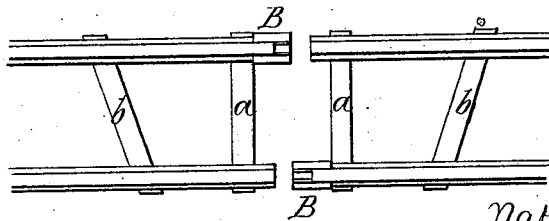

Fig. 5



Witnesses

Henry Smith  
Henry Howson, Jr.

Inventor

Nathan W. Conduct, Jr.  
by his Attorneys  
Howson and Son

# UNITED STATES PATENT OFFICE.

NATHAN W. CONDUCT, JR., OF JERSEY CITY, NEW JERSEY.

## IMPROVEMENT IN PORTABLE RAILWAYS.

Specification forming part of Letters Patent No. **204,007**, dated May 21, 1878; application filed January 7, 1878.

*To all whom it may concern:*

Be it known that I, NATHAN W. CONDUCT, Jr., of Jersey City, New Jersey, have invented a new and useful Improvement in Portable Railroads, of which the following is a specification:

The object of my invention is to make a portable railroad-track consisting of a series of self-contained sections, constructed for connection to each other, in the manner described hereinafter, so that the sections may be easily transported, quickly laid on the road-bed, and readily connected together.

In the accompanying drawing, Figure 1 is a plan view of a section of the track; Fig. 2, a side view of the same; Fig. 3, a perspective view, showing parts of two adjoining sections with coupling-chairs; Fig. 4, a perspective view, showing a modified arrangement of coupling-chairs; and Fig. 5, a plan view drawn to a reduced scale, and showing a modified arrangement of coupling-chairs.

Each section of the track shown in Figs. 1 and 2 consists of two rails connected together by transverse bars *a a* and diagonal bars *b b*, of wrought-iron, so that the two rails may always be maintained in their proper relative positions, both longitudinally and laterally, thereby rendering the section self-contained.

I prefer to make these bars of T-iron, as it is comparatively light, and at the same time rigid, while its flanges afford the best opportunities for riveting the bars to the flanges of the rails.

The number and arrangement of the transverse diagonal bars will depend, in a great measure, upon the length of the sections; but I may remark that I prefer to make the section comparatively short, especially if the road has to be laid in locations which are not easy of access by the usual means of transportation.

To each rail, at one end of each section, is riveted or bolted a portion of a coupling-shoe, B, which I prefer to make of plate or bar iron, bent as shown in Fig. 3, so as to tightly embrace the flange and web of the rail, the projecting portion of each coupling forming a socket for the end of one of the rails of an adjoining section.

One rail of each section may have at each end a coupling-shoe, B, and the opposite rail of the same section may be plain, as shown in Fig. 5.

The couplings may be made as shown in Fig. 4, each coupling having a base to be riveted to the flange of the rail, and one side adapted and riveted to the outer side of each rail, and extending up to the top of the same, so as to form a continuous tread.

These permanent self-contained sections of a railroad-track can be easily transported and far more cheaply laid on the prepared road-bed than ordinary rails.

The sections may be spiked to longitudinal sleepers in the bed, instead of to the usual cross-ties, the latter being unnecessary, owing to the self-contained character of the sections, which, in many cases, may be placed directly on the ground without intervening foundation.

I am aware that a portable railway consisting of frame-work composed of longitudinal, diagonal, and transverse beams, has been used as a foundation for railroad-rails. This I do not claim; but

I claim as my invention—

1. The within-described self-contained section of a railway, consisting of the combination of two rails and transverse and diagonal ties, all of wrought-iron, and permanently secured together, as set forth.

2. A portable railroad-track consisting of a series of sections, each composed of two rails, permanently connected together by transverse and diagonal cross-ties, in combination with shoes B, permanently secured to the rails of one section and adapted to the rails of the adjoining section, for the maintenance of the rails of the several sections in line with each other, all as set forth.

In testimony whereof I have signed my name to this specification in the presence of two subscribing witnesses.

NATHAN W. CONDUCT, JR.

Witnesses:

WM. PINTARD,  
HENRY MCDAWLAS.