

J. B. & G. R. ELLIOTE.
Well-Drilling Apparatus.

No. 204,143.

Patented May 28, 1878.

Fig. 1.

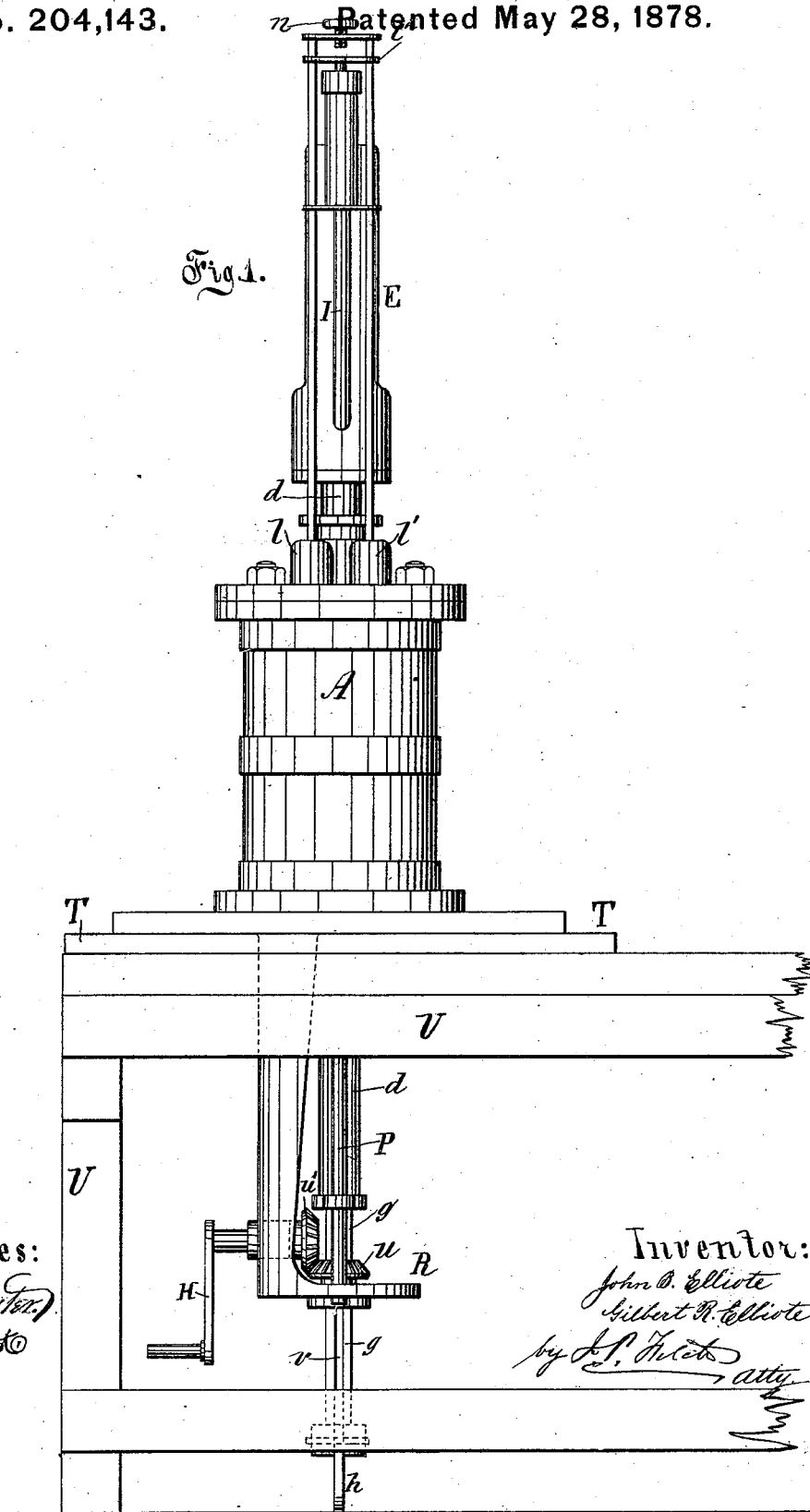

Witnesses:

Theodore H. Boston
T. E. Grant

Inventor:

John B. Elliott
Gilbert R. Elliott
by J. P. Hulet atty

J. B. & G. R. ELLIOTE. Well-Drilling Apparatus.

No. 204,143. Patented May 28, 1878.

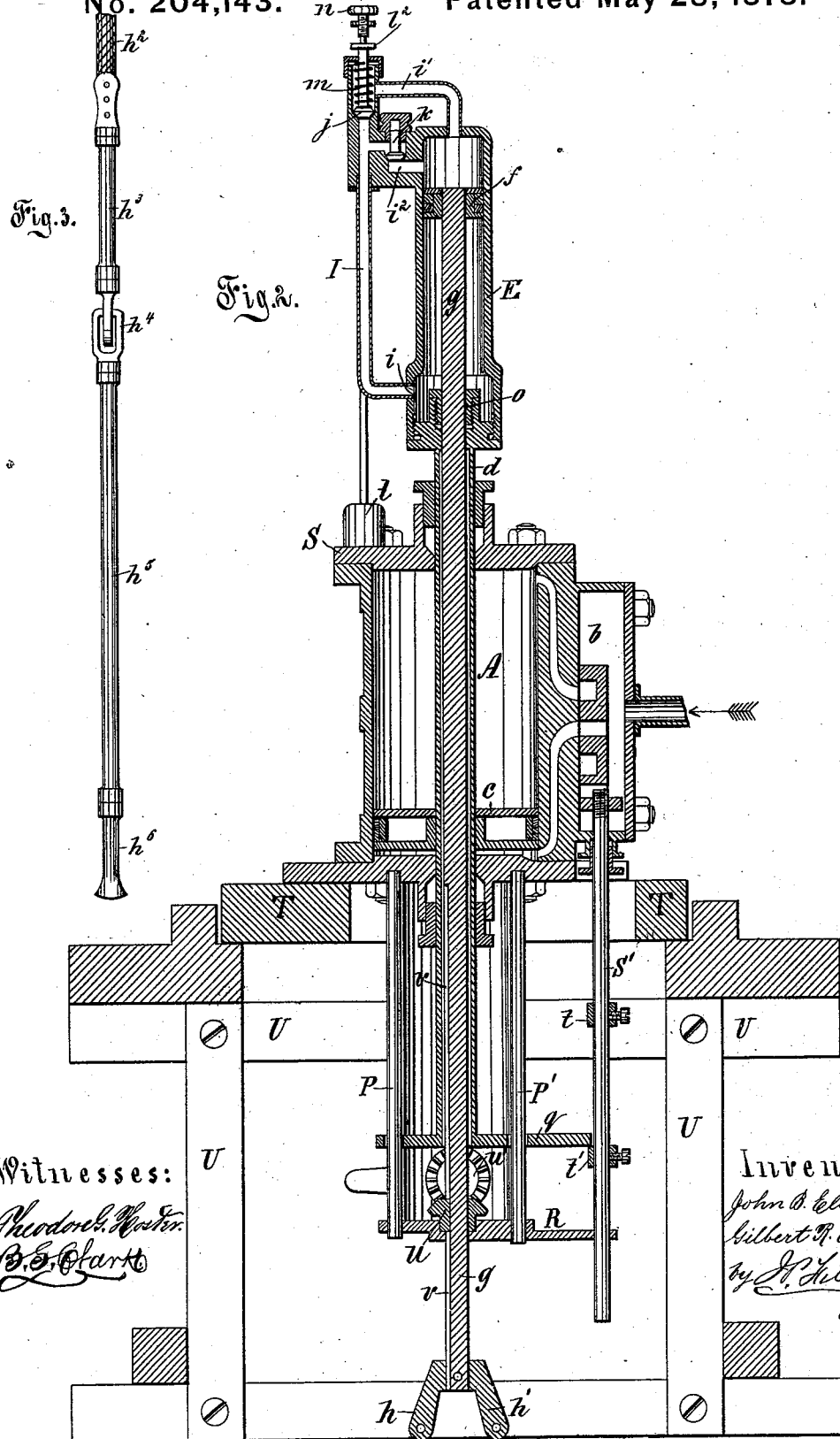

Witnesses:

Theodore H. Foster
B. E. Clark

Inventor:

John B. Elliott
Gilbert R. Elliott
by *J. Hitch*
Atty.

UNITED STATES PATENT OFFICE.

JOHN B. ELLIOTE AND GILBERT R. ELLIOTE, OF MONCTON, NEW BRUNSWICK,
CANADA.

IMPROVEMENT IN WELL-DRILLING APPARATUS.

Specification forming part of Letters Patent No. 204,143, dated May 28, 1878; application filed
April 1, 1878.

To all whom it may concern:

Be it known that we, JOHN B. ELLIOTE and GILBERT R. ELLIOTE, of Moncton, in the Province of New Brunswick, Dominion of Canada, have invented certain new and useful Improvements in Well-Drilling Apparatus, of which the following is a specification, reference being had to the accompanying drawings, forming part of the same.

Figure 1 is an elevation of a drilling apparatus containing our improvement. Fig. 2 is a vertical central section of the same; and Fig. 3 represents the sinker, the "jar," the drill-stem, and drill.

This invention relates to improvements in well-drilling apparatus especially adapted to Artesian wells, consisting of an automatic feed-cylinder, in which water or other liquid is used as a sustaining-column under the piston of the lifting-rod, to lift the said rod with its attachments, and to regulate automatically, by means of suitable valves and apertures, the required feed to be given to the drilling-tools in any kind of rock or earth, in connection with a steam-cylinder, with appropriate steam chest and valve, in which the motive power is excited, the whole being mounted on a traveling platform and frame, so that it can be readily placed directly over the well, and withdrawn at intervals for cleaning out the débris.

A is a steam-cylinder, of which *b* is the steam-chest, with valve; *c*, the piston; and *d*, the hollow piston-rod, passing through both ends of the steam-cylinder.

E is the lifting and automatic feed cylinder, (surmounting and attached to the upper end of the hollow piston-rod *d*), charged with water or other liquid.

f is the piston of the feed-cylinder, to which is attached the lifting-rod *g*, which rod works through the hollow piston-rod *d*. *h h'* are the clamps on the lower end of the lifting-rod *g*, to which the drilling apparatus is attached by a rope, *h²*, or other appropriate means. This drilling apparatus consists ordinarily of a sinker, *h³*, the jar *h⁴*, (a pair of large links,) the drill-stem *h⁵*, and drill *h⁶*.

I is a tube, communicating with the lifting and feed cylinder at its lower end by a single

orifice, *i*, permanently open, and at its upper end by two pipes or passages, *i¹ i²*, one of which, *i¹*, is controlled by the feed-valve *j*, and the other, *i²*, by the return-valve *k*.

l l' are weights, suspended by rods to the small cross-head *l²*, but which rest on the head S of the steam-cylinder when the piston in that cylinder is at the lower end of its stroke, as seen in Fig. 2. *m* is a spiral spring, which acts to close the valve *j*. These weights and spring serve to keep the feed-valve closed against the pressure of the liquid ascending the tube I.

n is the regulating feed-screw, regulating the extent of the feed given to the drilling-tools at each stroke of the apparatus. *o* is a gland and packing-box, to prevent the escape of liquid from the feed-cylinder through the hollow piston-rod *d*, in which the lifting-rod works.

P P' are the guide-rods for the cross-head *q*. R is the support for the guide-rods, attached to the lower head of the steam-cylinder. S' is the valve-stem, and *t t'* collars on the valve-stem. *u* is a mitered or beveled cog-wheel, working horizontally, through which the lifting-rod *g* works vertically. *u'* is a similar cog-wheel, working vertically, and gearing into the wheel *u*. *v* is a longitudinal groove in the lifting-rod, to receive loosely a pin which is secured in the cog-wheel *u*; and H is a crank, for imparting a turning motion to the lifting-rod, rope, and drill-tools through the cog-wheels *u'* and *u*. These devices for turning or rotating the drill may or may not be used.

T is a table or platform, upon which the apparatus is placed; and U a frame, on which the said platform is mounted and fitted to slide for adjustment over the well.

The working of the apparatus is as follows: Place the apparatus so that the lifting-rod will be directly over the well. Raise the lifting-rod *g* and piston *f* to near the top of the lifting and feed cylinder E. By raising the lifting-rod the water in the upper part of the feed-cylinder is forced through the return-valve *k* and through the tube I into the lowest part of the feed-cylinder—that is, under the piston *f*. While in this position attach the

rope and drilling-tools to the lifting-rod, so as to give the proper amount of the slack movement or jar in the coupling-links of the drilling-tools.

When steam enters the lower part of the steam-cylinder the piston *c* and the hollow piston-rod *d*, with the lifting feed-cylinder *E*, are projected upward; and when the feed-cylinder is raised so far as to bring the cross-head *l*, to which the weights *l'* are suspended, in contact with the regulating feed-screw, the valve *j* is closed by the additional pressure of said weights, and the lifting-rod, with all the drilling-tools attached, are sustained upon a column of water under the piston in the cylinder, and raised the length of the stroke of the steam-cylinder. When the click on the cross-head *g* of the steam piston-rod comes in contact with the upper collar *t* on the valve-stem *S'*, the exhaust of the lower port is opened and the piston *c* of the steam-cylinder drops with all its attachments—the feed-cylinder, lifting-rod, rope, and drilling-tools. At the lower end of the stroke the click on the cross-head of the steam piston-rod comes in contact with the lower collar *t'* on the valve-stem, and the lower port of the steam-cylinder is opened. Thus the piston *c* and hollow piston-rod *d*, with all attachments, are again elevated. As they ascend the weight of the lifting-rod, rope, sinker, and upper links of the jar and stem and drill of the drilling-tools are sustained by the column of water in cylinder *E* under the pressure of spiral spring *m*. When, however, the piston and cylinder ascend so far as to take the weight of the lower link of the jar and the stem and drill of the drilling-tools, the spiral spring *m* is compressed, so that the valve *j* is opened, and allows the liquid to pass from below the piston *f* to the upper end of the cylinder *E*, thus giving the requisite feed; but when they ascend so far as to bring the cross-head *l*, with which the valve *j* is connected, in contact with the feed-regulating screw *n*, the valve *j* is closed with sufficient force to sustain the whole weight of all vertical-moving parts during the remainder of the stroke of the piston *c* until they descend and the drill strikes the bottom of the well. This action is continued until the supporting-column of liquid is forced from under the pis-

ton in the feed-cylinder through the tube *I* and valve *j* into the upper part of the feed-cylinder, by which time the well has been deepened the length of the descent of the piston in the feed-cylinder, and then (or sooner) it will be necessary to shunt aside the drilling apparatus and withdraw the drills from the well, so as to clean out the débris. The operation above described is then repeated.

While the drilling is progressing a rotary motion may be imparted to the lifting-rod, rope, and drills by power being applied to the crank *H*.

What we claim as our invention, and desire to secure by Letters Patent, is—

1. The combination, with the vertical steam-cylinder *A*, provided with the hollow piston-rod *d*, of the automatic feed-cylinder *E*, with its piston *f* and piston-rod *g*, working in the said rod *d*, whereby drilling-tools attached to said rod *g* may be suspended upon a column of water in said cylinder *E* in the operation of drilling, as and for the purpose described.

2. The automatic feed-cylinder *E*, provided with the pipes or passages *i* *i'* *i''*, communicating with the pipe *I*, and the valves *j* and *k*, controlling the passages *i'* and *i''*, all constructed and combined to operate as and for the purpose described.

3. The combination of the vertical steam-cylinder *A* and piston *c*, provided with a hollow piston-rod, *d*, with the lifting and automatic feed cylinder *E* and piston *f*, provided with its rod *g*, working in rod *d*, together with pipe *I*, passages *i* *i'* *i''*, valves *j* and *k*, weights *l* *l'*, (one or both,) spring *m*, and feed-regulating screw *n*, all constructed to operate as and for the purpose described.

4. The combination of the cylinders *A* and *E*, pistons *c* and *f*, rods *d* and *g*, clamps *h* *h'*, gears *u* and *u'*, the said gear *u* having a pin or feather working in groove *v* in rod *g*, and the crank *H*, all constructed and arranged to operate as and for the purpose described.

Witness our hands this 26th day of March, 1878.

JOHN B. ELLIOTE.
GILBERT R. ELLIOTE.

Witnesses:

GEORGE CASH,
H. D. CHURTUS.