

L. BLANCK.
Safety-Brake for Railway-Trains.
No. 204,186. Patented May 28, 1878.

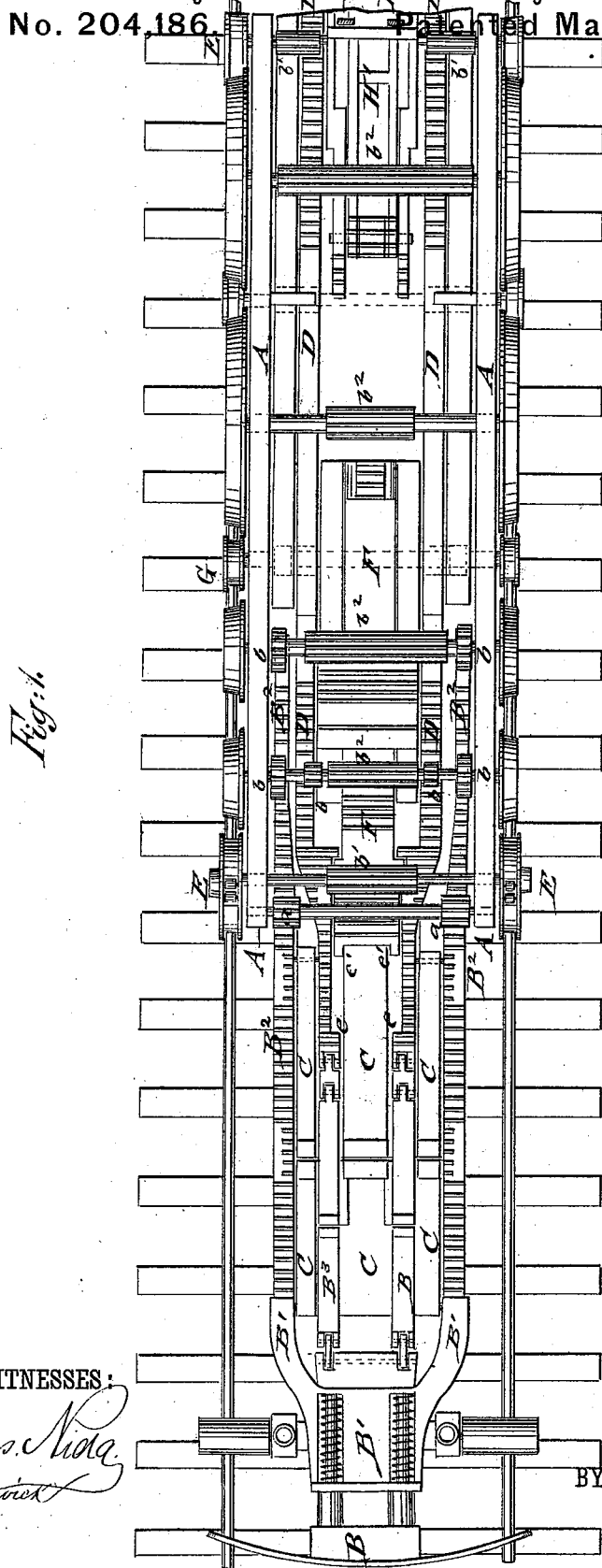

Fig. 1.

WITNESSES:
Chas. Nida
C. S. Squire

INVENTOR:
L. Blanck
 BY *Munroe*

ATTORNEYS.

L. BLANCK.
Safety-Brake for Railway-Trains.
No. 204,186. Patented May 28, 1878.

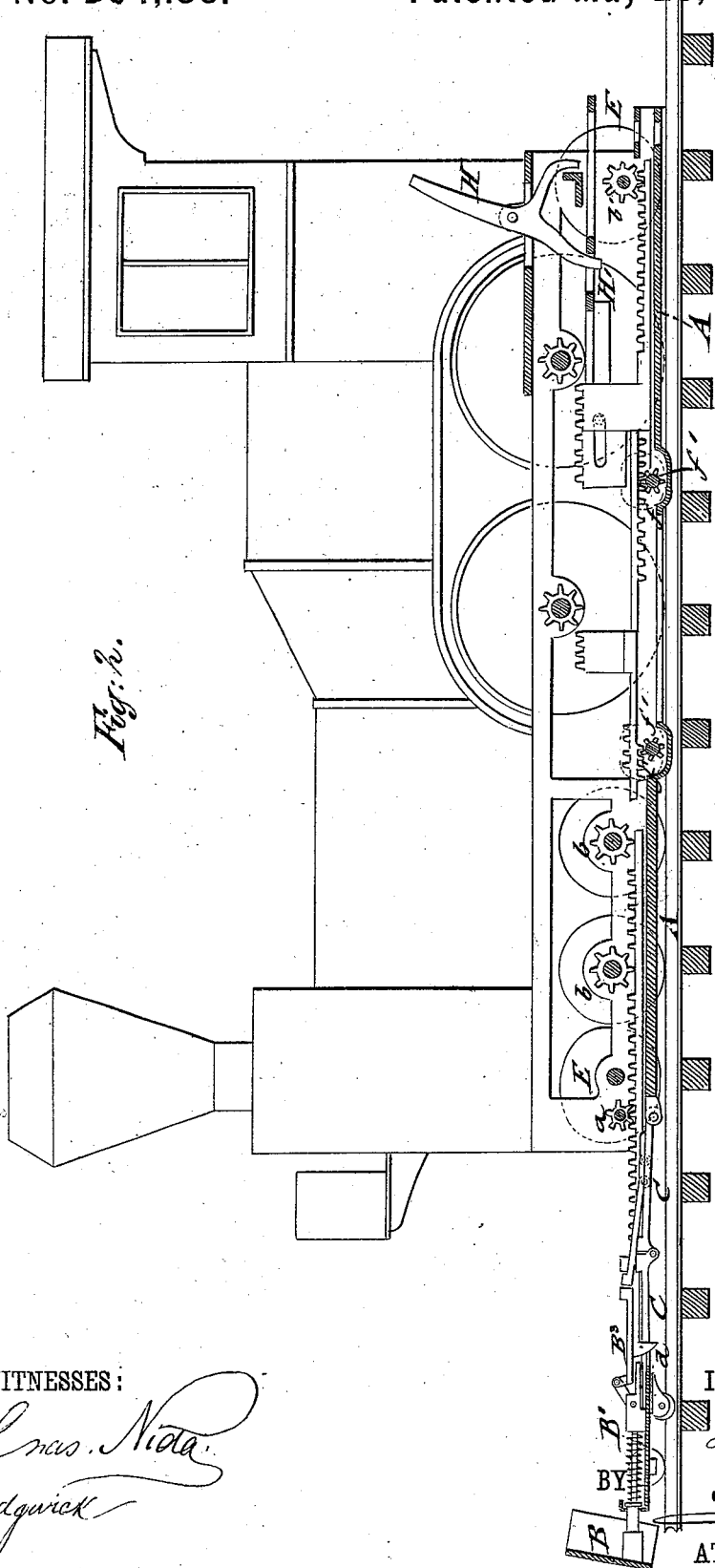

Fig. 2.

WITNESSES:

C. W. Nida
C. Sedgwick

INVENTOR:

L. Blanck
Attorney

BY

ATTORNEYS.

L. BLANCK.
Safety-Brake for Railway-Trains.
No. 204,186. Patented May 28, 1878.

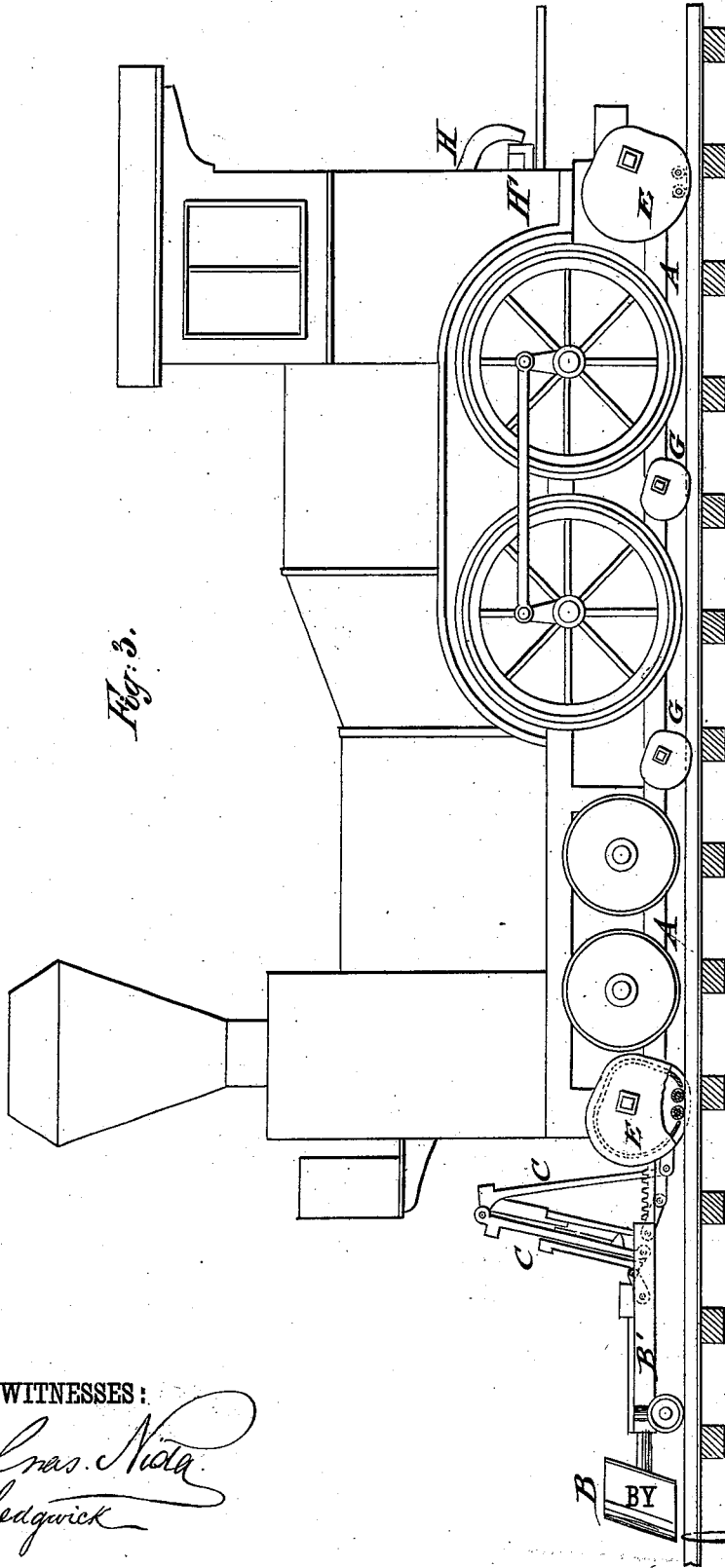

Fig. 3.

WITNESSES:

Cras. Nida
G. Sedgwick

INVENTOR:

L. Blanck
Munroe

ATTORNEYS.

UNITED STATES PATENT OFFICE.

LOUIS BLANCK, OF NEW YORK, N. Y..

IMPROVEMENT IN SAFETY-BRAKES FOR RAILWAY-TRAINS.

Specification forming part of Letters Patent No. **204,186**, dated May 28, 1878; application filed May 8, 1878.

To all whom it may concern:

Be it known that I, LOUIS BLANCK, of the city, county, and State of New York, have invented a new and Improved Safety-Brake for Railroad-Trains, of which the following is a specification:

In the accompanying drawings, Figure 1 represents a plan view of my improved safety-brake, shown as attached to the bed-frame of a locomotive. Fig. 2 is a vertical longitudinal section of the same; and Fig. 3, a side view, showing the locomotive as raised from the rails by the action of the safety-brake.

Similar letters of reference indicate corresponding parts.

The object of this invention is to furnish an improved safety brake or attachment for locomotives and railroad-cars, by which the entire train, either by a collision with another train or by contact with any obstruction, is first raised from the rails, and then moved in backward direction for the distance of a few feet, so that all danger of accident is avoided, and no other sensation than that of a slight rocking motion exerted. The attachment is constructed so as to admit of being worked by the engineer from the cab of the locomotive, or, if desired, from any car of the train.

The invention consists of the arrangement, below the locomotive or car, of three separately-sliding and intermittingly-toothed sections, that are guided one within the other and arranged to engage pinions on the axles of the front and hind wheels. The outer slide-section is extended to some distance in front of the locomotive, and connected to a sliding and spring-acted buffer-head, that is supported by rollers or suspension-chains at suitable height above the rails, the rear block of the buffer-rods being connected by guided actuating-levers with hinged and folding brace-pieces, that fold together to admit the successive working of the toothed sections.

The intermediate section engages, by front shoulders, the innermost slide-section after both the outer and intermediate sections have been pushed back, so as to throw the innermost section into action, and produce, in connection with the pinions of the revolving axles, first, the rising of the locomotive or car, by eccentric front and hind wheels, to some distance from the rails, and then, by the inter-

meshing of teeth at the under side of the inner toothed sections, the backward motion of the locomotive or car by means of smaller auxiliary eccentric-wheels.

Referring to the drawing, A represents the supporting-frame of my improved safety-brake attachment, which frame is hung to the bed-frame of the locomotive or car below the axles of the wheels of the same, and arranged in such manner as to properly support the operating parts of the safety-brake. At suitable distance in front of the locomotive is arranged a buffer-head, B, that is made of suitable length, and supported either on spring-bearings of a supplementary front axle, with end rollers or wheels, or that is hung by means of suspension-chains at a certain distance from the rails. The buffer-head B proper is guided by means of spring-acted buffer-rods in a recessed and perforated front piece, B¹, and the rear block of the buffer-rods hinged to folding brace-pieces C, that are hinged at their connecting ends to each other and at their opposite ends to the supporting-frame. The brace-pieces C face each other at their joints by means of enlarged heads. The front piece B¹ of the buffer-head is extended backward at both sides of frame A, so as to form an exterior slide-section, B², that is toothed at the upper side for engaging the retaining-pinions *a* at the front of frame A and fixed pinions *b* of the axles of the front wheels as soon as the buffer-head is moved back by collision or other obstruction. The pinions of the front axles revolve in smooth intermediate spaces of the outer toothed sections until the outer slide-section is pushed back, so that the pinions have a chance to mesh with the teeth of the slide-section by the backward motion of the same.

By the backward motion of the buffer-head the rear block of the same lifts, by a rear plate striking a bottom catch, *d*, of the central front brace-piece C, the front set of brace-pieces, in connection with levers B³, hinged to the rear block and guided along the brace-pieces C, and with a second set of levers, B³, that are hinged to the front end of an intermediate toothed slide-section, D, and serve to raise the rear brace-pieces. The hinged brace-pieces C are thereby thrown into upright or folded-up position, as shown in Fig. 3, and ad-

mit thereby the backward motion of the outer slide-section B² and the engaging of the pinions of the front axles.

The meshing of the pinions of the revolving axles with the toothed intermediate slide-section causes thereby the backward motion of the same, which back motion is accomplished whenever the outer slide-section B² has been moved back a certain distance.

The intermediate slide-section D is extended throughout the entire length of the locomotive or car, and is made smooth at the middle part, but toothed again at the rear part, while the outer slide-section extends only along a portion of the length of the locomotive or car, and engages their separate rear slide-pieces that serve to transmit the motion to a corresponding slide-section of the car next adjoining.

The intermediate toothed section D engages, as soon as the brace-pieces are folded up by the backward motion of the buffer-head and the slide-section D is started backward by the pinions *b* of the front axles, pinions *b*¹ on the axles of eccentric front and rear wheels E, that are flattened off at one side and extended beyond the periphery of the front wheels at the opposite side, so as to produce, when the axles are revolved by the backward motion of the toothed intermediate slide-section D, the forward motion of the larger eccentric-wheels E, and thereby the lifting of the entire locomotive or car bodily above the rails to such a distance as the eccentric parts of the wheels E project below the circumferences of the front and rear wheels of the locomotive or car. The first effect of a collision and of the consequent backward motion of the outer and intermediate slide-section will therefore be the instant raising of the locomotive or car by the joint action of the forward motion of the wheels and of the backward motion imparted by the collision to the slide-sections.

The intermediate section D is made at its front end somewhat longer than the innermost toothed slide-section F, and provided with a number of teeth at the forward-extended front portion, and with inwardly-projecting front shoulders *e*, that engage similar shoulders *e*' of the innermost section F, so that as soon as the intermediate slide-section has been moved back sufficiently to engage the innermost slide-section the latter is set in motion and the toothed portions of the same engaged by central pinions *b*² of the front and rear axles, the rear axles engaging raised toothed portions of the same.

The backward motion of the intermediate slide-section D also sets, by means of bottom teeth *f* of the same and intermeshing pinions *f*¹, the axles of auxiliary smaller eccentric wheels G in backward motion after the locomotive or car has been raised by the eccentric-wheels E. The axles of the eccentric-wheels are so arranged between the supporting-wheels of the locomotive or car as to properly balance the weight of the same.

The backward motion of the outer slide-

section F, actuating the larger eccentric-wheels, and the motion of the intermediate slide-section D, that actuates the smaller eccentric-wheels, cause, first, the raising of the entire car or locomotive, then the backward motion of the same, and produce, finally, by the motion of the innermost slide-section F with its toothed parts, the alternate engaging of the supporting and auxiliary axles, and consequently a forward motion alternating with the raising and the backward motion of the locomotive or car. During the lifting and backward motion the supporting-wheels continue to revolve by the power of the engine imparted to them before the collision.

After a revolution of the larger eccentrics and of the smaller eccentrics is completed, the locomotive or car is brought back on the rails again by the intermittent action of the innermost slide-section, the locomotive or car is raised again and moved in backward direction, as before described.

The pinions of the axles revolve during the time when the wheels of the locomotive or car form contact with the rails in intermediate plain or untoothed spaces of the slide-sections. This succession of the raising, backward, and lowering motions of the train produces no other effect upon the passengers in the train but that of a slight rocking, so that in case of a collision of two trains no accident can be produced, but only a slight and hardly noticeable motion exerted throughout the train.

The buffer-head and the outer slide-sections are employed as safeguards for collisions of the trains, they being not called in action when the train is to be stopped, in case of danger, by the engineer or conductor. The buffer-head arrangement may also be provided at the under side with a projecting wheel, that provides against danger in passing on a draw-bridge or over any other obstruction. The safety-brake arrangement may also be thrown into action from the cab of the locomotive, or from every car, by suitable lever mechanism, a forked hand or power-lever, H, being shown in the drawing in connection with slide guide-rods H' connected to the intermediate and innermost sections, so as to cause their backward motion and throw them in gear with the pinion of the axles, to be then moved backward by the revolving motion of the axles.

The front portion and levers of the intermediate section are guided by side flanges along grooves of the front brace-pieces, so as to be moved independently backward and forward of the braces and of the outer toothed slide-section.

The action of the larger and smaller eccentric-wheels is the same as that before described as caused by a collision or obstruction, so that the same attachment may be used, in case of danger, for stopping the entire train at a moment's notice.

For the purpose of resetting the different sections of the brake mechanism after a collision or stoppage has taken place, the actuat-

ing-lever must be thrown into opposite direction and the engine reversed, so that thereby the toothed sections are moved forward by the axles, and simultaneously the eccentric-wheels returned to their former normal position without forming contact with the rails. The train is then in condition to proceed in the usual manner.

The locomotive and cars are coupled together in any suitable manner, but mechanism provided by which the brake attachment of each car is properly actuated by that of the car or locomotive next preceding. The brake mechanism is furthermore so hung by its frame, in connection with the car-frame proper, that the same may round curves without difficulty, and so as to always keep the brake mechanism intact for work. The car-frame may also be arranged with posts having spring-flanges or disks that are intended to retain the locomotive or car on the track during the different motions they go through in case of collision or stoppage.

Having thus described my invention, I claim as new and desire to secure by Letters Patent—

1. The combination of locomotive or car axles having fixed pinions, and of a series of toothed and successively-actuated slide-sections arranged below the car-frame, with a set of eccentric-wheels that raise the locomotive or car, and with a set of intermediate eccentric-wheels that impart then a backward motion to the same, substantially as and for the purpose set forth.

2. The combination of a safety-brake, consisting of toothed and successively-actuated slide-sections that are arranged one within the other, and of eccentric raising and backing

wheels operated thereby, with a sliding and spring-acted front buffer-head, and with suitable actuating-lever mechanism at the rear part, so as to throw the safety-brake into action from the front or rear, substantially as shown and described.

3. The combination of the intermediate toothed slide-section, which is guided along the brake-pieces of the buffer-head, and of the innermost toothed slide-section, with lever mechanism at the rear of the locomotive, and with fixed pinions of the axles of the car-wheels and eccentric-wheels, so as to operate the brake mechanism independently of the buffer-head and outer slide-section, substantially as described.

4. The combination of the outer toothed slide-sections, having spring-acted buffer-head, with the intermediate toothed section, and with hinged and folding brace-pieces and lifting-levers, so that the slide-sections are successively thrown into action to engage the pinions of the axles of the car-wheels and of the eccentric-wheels, substantially as specified.

5. The combination of the intermittingly-toothed intermediate slide-section, having guided front portions, inwardly-projecting front shoulders, and bottom teeth, and of the innermost intermittingly-toothed slide-section having front shoulders, with pinions on the axles of the car-wheels and of the eccentric-wheels, to cause, by the backward motion of the slide-sections, the successive raising, backing, and lowering of the locomotive or car, substantially as set forth.

LOUIS BLANCK.

Witnesses:

PAUL GOEPEL,
C. SEDGWICK.