

A. C. BLOUNT.  
Gas-Meter.

No. 204,188.

Patented May 28, 1878.

Fig1.

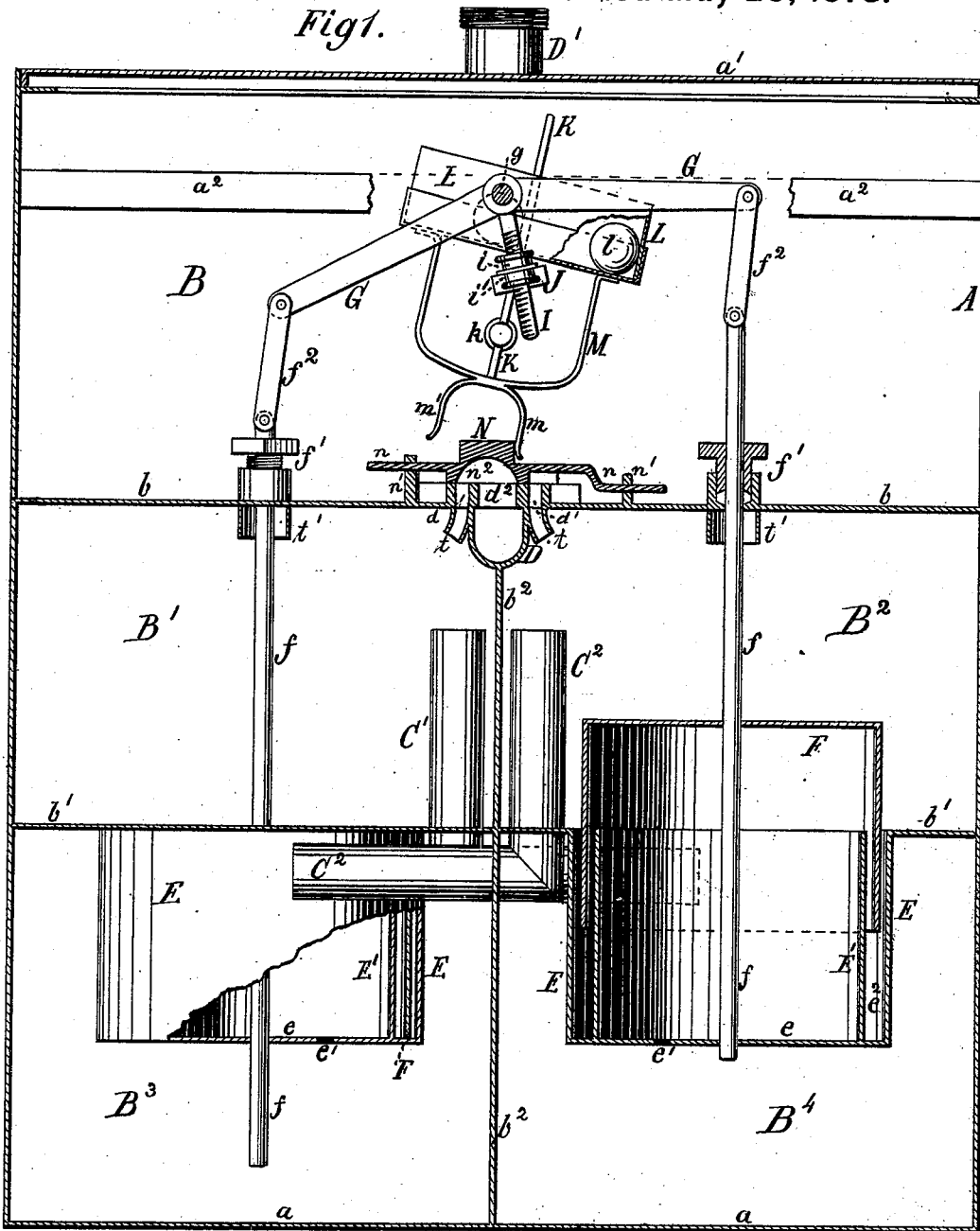

Fig2.

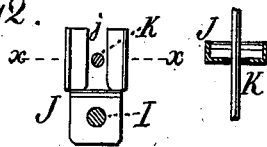
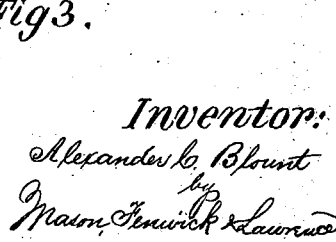

Fig3.



Witnesses:  
*James Martin Jr.*  
*J. P. Theodore Lang.*

Inventor:  
*Alexander C. Blount*  
*by*  
*Mason, Knicker & Lawrence*

A. C. BLOUNT.  
Gas-Meter.

No. 204,188.

Patented May 28, 1878.

Fig 4.

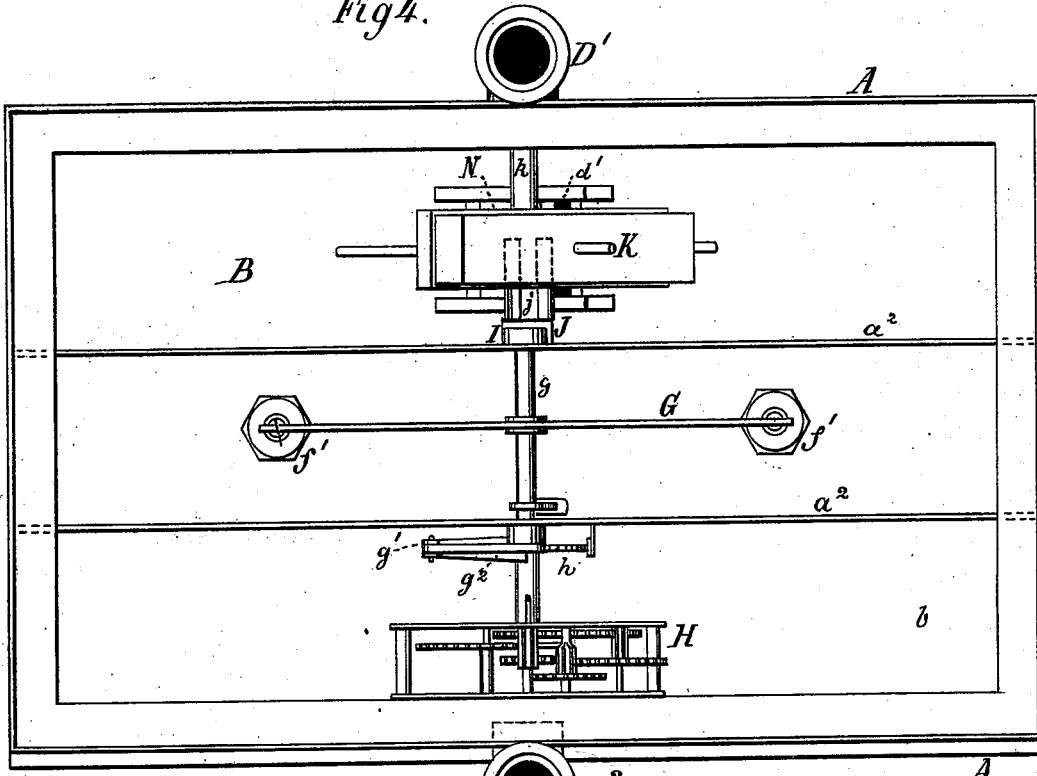
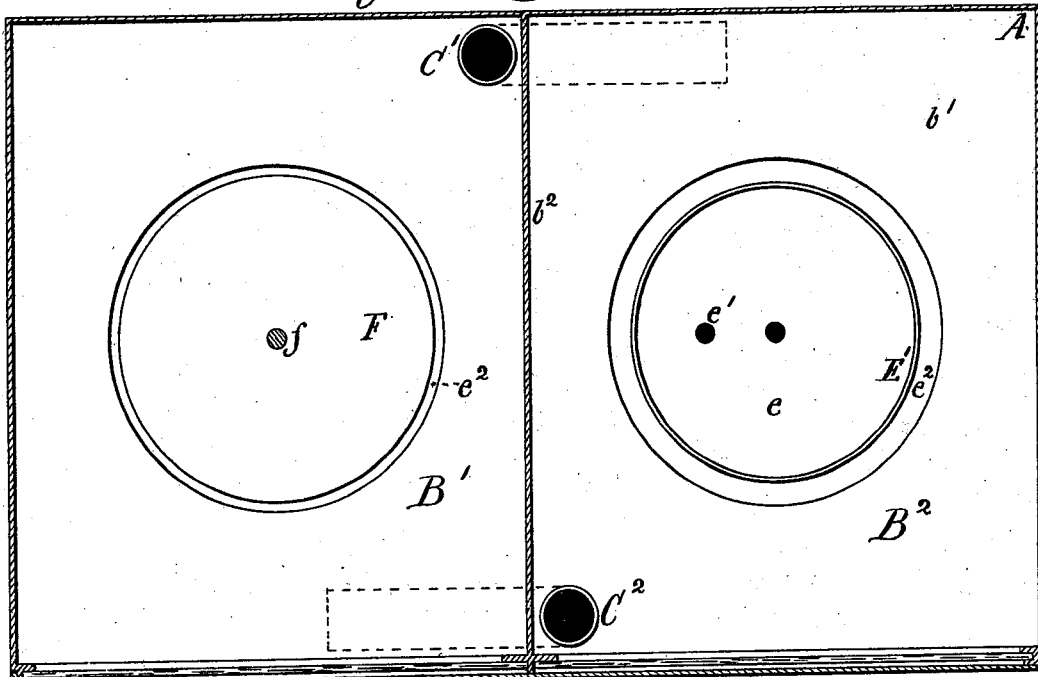

Fig 5.



Witnesses:  
James Martin Jr.  
J. P. Theodore Lang.

Inventor:  
Alexander C. Blount  
(Mason, Fendrick & Lawrence)

# UNITED STATES PATENT OFFICE.

ALEXANDER C. BLOUNT, OF PASCAGOULA, MISSISSIPPI.

## IMPROVEMENT IN GAS-METERS.

Specification forming part of Letters Patent No. 204,188, dated May 28, 1878; application filed March 13, 1878.

*To all whom it may concern:*

Be it known that I, ALEXANDER C. BLOUNT, of Pascagoula, in the county of Jackson and State of Mississippi, have invented a new and Improved Gas-Meter; and I do hereby declare that the following is a full, clear, and exact description of the same, reference being had to the accompanying drawings, forming part of this specification, in which—

Figure 1 is an elevation of my improved gas-meter, having certain parts removed or broken away to show the interior construction, on one side in elevation, on the other in section. Fig. 2 is a detail plan view of a valve-gear connection used therein. Fig. 3 is a vertical section of the same in the line *x x*. Fig. 4 is a plan view of my improved gas-meter; and Fig. 5 is a central horizontal section through its middle chamber, showing one of the packing-chambers in full.

The nature of my invention consists in certain constructions, combinations, and arrangements of parts, hereinafter fully described and specifically claimed, whereby a gas-meter is produced which is very easily operated by the slightest pressure of gas, and which is not liable to leak.

In the drawings, A represents the outer shell of a gas-meter; *a*, its bottom, and *a'* its top cover.

The inner space is divided into a number of chambers, in the following manner: An upper chamber, B, is formed by a horizontal partition, *b*. Two middle chambers, B<sup>1</sup> B<sup>2</sup>, are formed by partitions *b*, and a lower partition, *b'*, and a vertical central partition, *b''*, extending from partition *b* to the bottom *a*. Between the partitions *b'* *b''* and bottom *a* chambers B<sup>3</sup> B<sup>4</sup> are formed. The chambers B<sup>1</sup> B<sup>4</sup> are connected by means of an angular pipe, C<sup>1</sup>, and the chambers B<sup>2</sup> B<sup>3</sup> are connected by a similar pipe, C<sup>2</sup>. The chambers B<sup>1</sup> B<sup>2</sup> and B<sup>3</sup> B<sup>4</sup> are connected by ports *d d'*, between which an exhaust-port, *d''*, communicates with an eduction-pipe, D, below, connected with an outer eduction-pipe, D<sup>1</sup>, of the meter. An induction-pipe, D<sup>2</sup>, conducts the gas into the chamber B of the meter. The partition *b'* is provided with two central cylindrical vessels, E, extending into the chambers below, and one of them opening into

chamber B<sup>1</sup>, the other into chamber B<sup>2</sup>. The bottoms *e* of the vessels E are provided with holes *e'*, whereby they communicate with the chambers below the partition *b'*. An annular chamber, *e''*, is formed in each vessel E by a concentric wall, E<sup>1</sup>, of smaller diameter, which chamber is filled with mercury to form a liquid packing, and wherein a hood-valve, F, on a central stem or rod, *f*, moves up and down. The stem *f* passes through a stuffing-box, *f'*, in the partition *b*, and is above that connected by means of a link, *f''*, with a balance-lever, G. The fulcrum-rod *g* of the balance-lever G is hung in bearings *a''* of the chamber B, and by means of a lever, *g'*, and pawl *g''* operates the ratchet-wheel *h* of an ordinary counting or registering apparatus, H, of the meter. An arm, I, provided with screw-threads, is attached to the rod *g*, and has a forked plate, J, fastened to it by means of thumb-nuts *i i'*. Through the slot, or between the prongs *j* of the forked plate J, a rod, K, passes, which has its fulcrum at *k*, and to the upper part of which an oblong box, L, is fastened. On each side of the rod K the box L has a ball, *l*, placed in it, which follows the declination of the box. The lower ends of the box L are supported by a brace, M, which is fastened to the lower part of the rod K, and has two tappet-arms, *m*, whereby it moves a slide-valve, N. The slide-valve N has a longitudinal guide-rod, *n*, fitted into lugs *n'*, and an exhaust-chamber, *n''*, and slides over the face of the ports *d d'* *d''*, similar to the slide-valve of a steam-engine. In practice, the partition *b'* is slightly depressed around the vessels E, in order to cause the mercury to flow back into its annular chamber *e''*, if by accident it should have been caused to leave the same.

There should be a tube (indicated at *t*) around the valve-openings *d d'*, which tubes should project a little way into the chambers B<sup>1</sup> and B<sup>2</sup>, to prevent the mercury from escaping into and through the valve in case of the overturning of the meter. There should also be tubes (indicated at *t'*) around the stuffing-boxes *f'*, which tubes should descend a little way into the chambers B<sup>1</sup> and B<sup>2</sup>, to prevent the escape of mercury through the stuffing-boxes in case of overturning the meter.

Operation: Gas from one of the gas-mains is

introduced through the pipe  $D^2$  into the chamber B, and, the port  $d^1$  being open, the gas passes through it into the chamber  $B^2$  and through the pipe  $C^2$  into the chamber  $B^3$ , whence it enters the vessel E through the opening  $e^1$ . The hood F in chamber  $B^2$ , being at its highest elevation, is now depressed by the pressure of the gas from above, and the hood F in chamber  $B^1$ , which was at the end of its downstroke, is now moved up by the pressure of the gas from below in the vessel E. The positions of the levers G and I are thus reversed, and the plate J moves the rod K, and with it the box L, into an opposite inclined position. While the box L is being reversed the balls  $l$  remain at the right termination of their course until the box L has assumed a horizontal position; but as soon as it begins to incline over to the left the balls suddenly roll to the left termination of their courses, and by their momentum and weight instantly finish the oscillating stroke of the box L, and thus cause the valve N to quickly and properly complete its stroke. By this operation the port  $d$  becomes opened, and the exhaust-port  $d^2$  is, by means of the exhaust-chamber  $n^2$ , connected with the port  $d^1$ . The gas in the chamber B now enters the chamber  $B^1$  through the port  $d$ , and the chamber  $B^4$  through the pipe  $C^1$ , and the vessel E through the opening  $e^1$ . By the pressure of the gas, the position of the hoods F F becomes reversed again, and thus the capacity of the chambers  $B^2$  and  $B^3$  becomes reduced, so that a portion of gas is driven therefrom, through the opening  $e^1$ , the pipe  $C^2$ , the port  $d^1$ , the chamber  $n^2$ , and the port  $d^2$ , into the pipe D and  $D^1$ , from whence it is conducted to the chandeliers of the building. As fast as the gas is consumed the supply-gas from pipe  $D^2$  flows through the meter in the described way, reversing the position of the hoods F and the valve N, and at each upstroke the left hood F pushes the wheel  $h$  one tooth forward, thereby registering the amount of gas delivered into the pipe  $D^1$ .

The slot  $j$ , Figs. 2 and 3, is made of such width and is fastened to the arm I at such altitude that the rod K has a certain amount of play therein, in order that the box L shall be

operated by the balls  $l$  just when the hoods F have almost finished their stroke, and so that the stroke of the hoods shall be finished at the same time that the balls  $l$  terminate their movement. The tappet-arms  $m m'$  are also constructed at such distances apart that they do not touch or operate the valve N until the oscillation of the box L is nearly finished.

The packing material for the hoods F is quicksilver, which has the advantage over other metal packing in that the gas cannot corrode it, and also has the advantage over other liquid packing in that it does not evaporate nor freeze, nor become gummed and stiff.

Having described my invention, what I claim, and desire to secure by Letters Patent, is—

1. In a gas-meter, the combination of the valve-chamber B, having ports  $d d^1 d^2$  and valve N, the chambers  $B^1 B^2 B^3 B^4$ , having pipes  $C^1 C^2$ , the operating-hood F, the lever G, arm I, and rod K, and the tappet-arms  $m m'$ , whereby the circulation of the gas through the measuring mechanism is effected, substantially as set forth.

2. The combination of the oscillating box L, provided with two chambers, in each of which a ball is placed, the rod K, tappets  $m$ , rock-shaft G, arm I, and forked plate J, substantially as described.

3. The combination of the perforated vessels E, rigid movable hoods F, gas-chambers for supplying the gas alternately to the inner and outer surfaces of the tops of the respective hoods, so that one hood shall ascend while the other descends, a slide-valve, N, and appropriate mechanism for imparting sudden action to the valve, substantially as described.

4. The combination of the rock-shaft  $g$ , arm I, forked plate J, and oscillating rod K, substantially as and for the purpose set forth.

Witness my hand, in the matter of my application for a patent for an improved gas-meter, this 11th day of March, A. D. 1878.

ALEXANDER C. BLOUNT.

Witnesses:

T. B. MORRELL, Jr.,  
HENRY C. HAWKINS.