

# E. W. FAWCETT. Meat-Chopper.

No. 204,209.

Patented May 28, 1878.

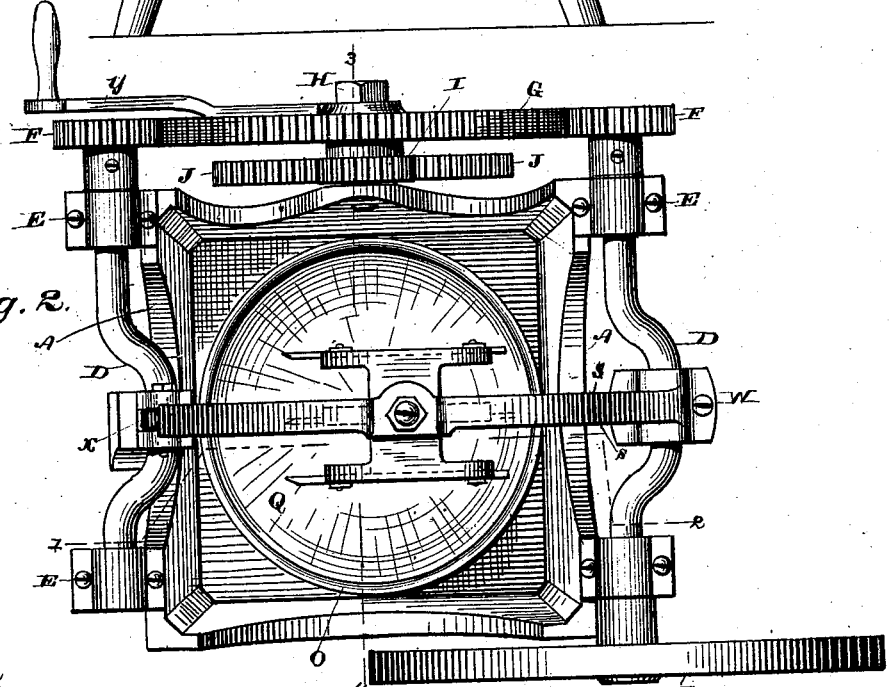
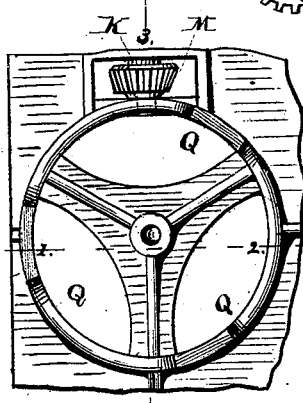
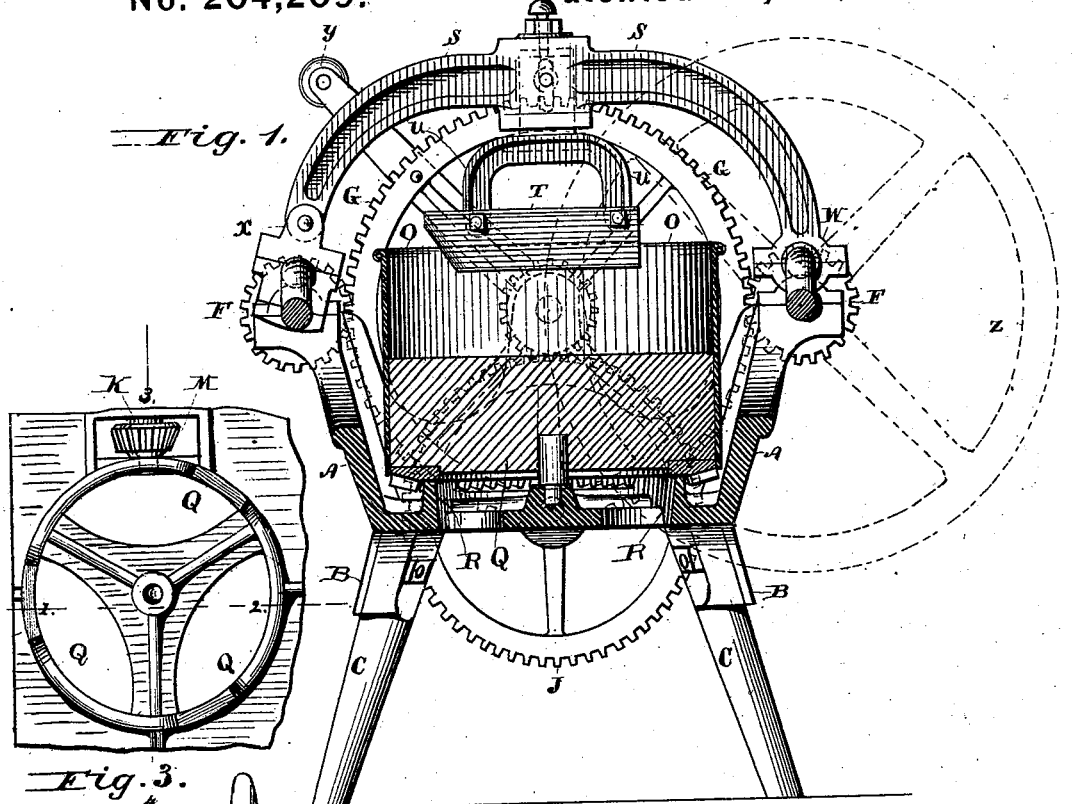

Attest  
 J. D. Perrine,  
 Alvin M. Doug.

E. W. Fawcett. Inventor  
 By H. S. A. [Signature]

# E. W. FAWCETT. Meat-Chopper.

No. 204,209.

Patented May 28, 1878.

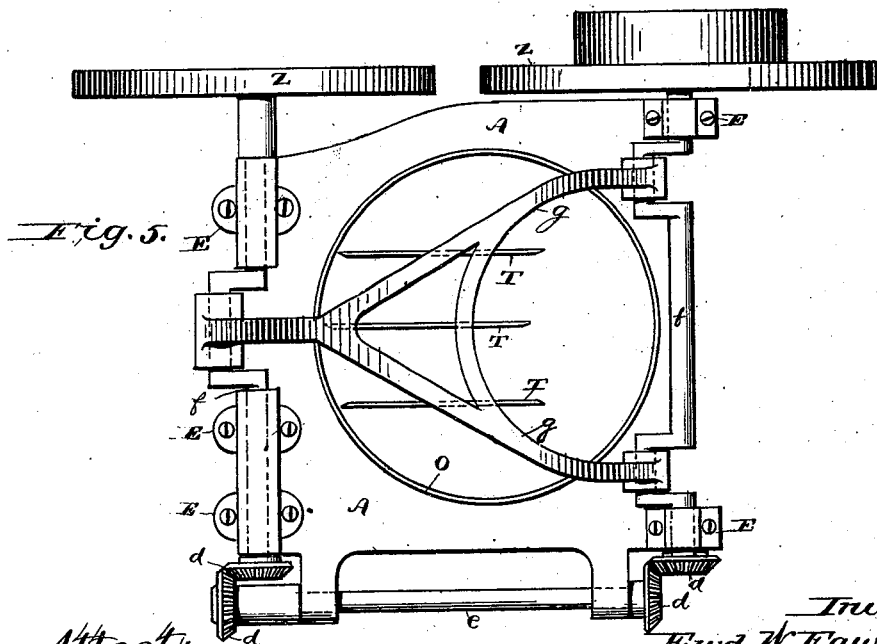
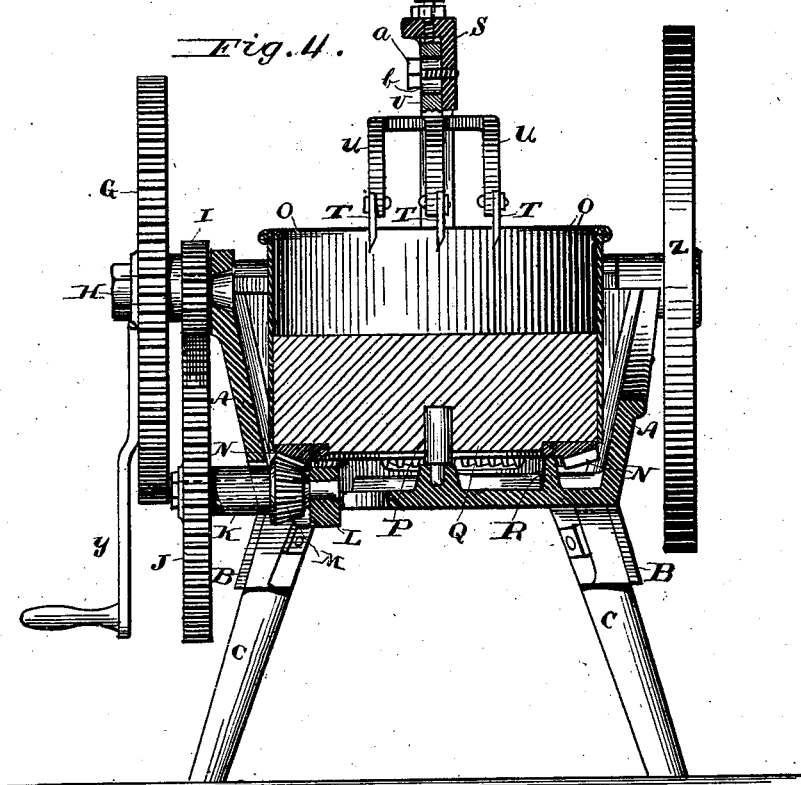

Attest:  
*H. L. Perrine*  
*Albin M. Bong.*

Inventor:  
*Edw W. Fawcett.*

By: *H. A. A. A. A.*  
 Atty.

# UNITED STATES PATENT OFFICE.

EDWARD W. FAWCETT, OF SALEM, OHIO, ASSIGNOR TO SILVER & DEMING MANUFACTURING COMPANY, OF SAME PLACE.

## IMPROVEMENT IN MEAT-CHOPPERS.

Specification forming part of Letters Patent No. **204,209**, dated May 28, 1878; application filed April 30, 1878.

*To all whom it may concern:*

Be it known that I, EDWARD W. FAWCETT, of Salem, in the county of Columbiana and State of Ohio, have invented certain new and useful Improvements in Meat-Choppers; and I do hereby declare that the following is a full, clear, and exact description thereof.

This invention relates to certain improvements in meat-choppers; and the invention consists in the construction, arrangement, and combination of parts, which will be hereinafter more fully set forth.

In order to enable others skilled in the art to which my invention appertains to make and use the same, I will now proceed to describe its construction and arrangement, reference being had to the accompanying drawings, which form a part of this specification, and in which—

Figure 1 is a vertical section taken on line 1 2 of Fig. 2. Fig. 2 is a top view of my meat-chopper. Fig. 3 is a section of the frame, showing the flanges on which the hopper rests. Fig. 4 is a section taken on line 3 4 of Fig. 2, and Fig. 5 is a modification of the arrangement shown in Fig. 2.

A denotes the frame. This frame is preferably cast in one piece, and formed with four extensions, B, to which are secured by bolts, or in any other detachable manner, the supporting-legs C.

On opposite sides of the frame A are arranged crank-shafts D. These shafts are held in suitable bearings E at each corner of the frame, as shown in Fig. 2, and provided with pinions F, which gear with a large or master cog-wheel, G, keyed or arranged in any other suitable manner on a stud, H, extending out from the side of the frame. By this arrangement the master cog-wheel serves to drive the pinions, as well as maintain the cranks of the crank-shafts in the same relative position.

On the stud H is also rigidly secured a pinion, I, which gears with a cog-wheel, J, rigidly secured to the extended end of a shaft, K, which passes through a suitable opening at the bottom of the frame, and supported by a suitable bearing, L, as shown in Fig. 4 of drawings.

The inner end of the shaft K is provided, contiguous with the bearing L, with a bevel-pinion, M, which meshes with suitable gear N on the bottom of the hopper O. The hopper is supported and revolves on a suitable pin or pivot, P, projecting downwardly from the chopping-block Q, the extended or smaller end of which passes into a correspondingly-shaped hole in a projection on the bottom of the frame, as shown in Fig. 4. The hopper travels on and is prevented from wobbling by a circular flange, R, extending up from the bottom of the frame A.

A semicircular or other suitably-shaped beam, S, arranged transversely across the hopper, extends from one crank-shaft D to the other. To this beam S, about half-way between said crank-shafts, is secured, in an adjustable manner, a knife-holding mechanism, constructed with curved arms U, as shown, to which latter the knives T are secured. The vertical extension or shank V of this knife-holding mechanism passes up into a recess in the beam S, and is held in place by a screw, *a*, passing through the slot *b* into the beam. The screw *c*, passing down through the top of the beam S, not only aids in adjusting the knives, but is intended more especially as a guard to prevent any backward movement or slipping of the shank V in its fastening upon the knives meeting with any resistance in their descent.

One end of the beam S may be secured to the crank of one of the crank-shafts D by a rigid joint or box, W, and the other end secured to the crank of the opposite crank-shaft D by a flexible or hinged joint or box, X, as shown in Fig. 1.

The lower half of the box at the flexible end of the beam is weighted, as shown, in order to assist in maintaining the box in its normal position.

The lower half of one or both of the boxes may be hinged to the upper half, and secured by screw-bolts, or in any other suitable manner, admitting of the ready removal of the beam, when desired.

It is evident that by this construction the movement communicated to the knives will

be such that any given point on the knives will describe a circle the radius of which is equal to the length of the cranks secured to or formed by the shafts D, the knives being at all times held in a horizontal position.

One or both ends of the knives may be curved or rounded off, in order to obviate any tendency to throw or crowd the meat against the side of the hopper.

In the construction shown by drawing, the block may be removed by withdrawing the pin at the flexible end of the beam and turning the beam over clear of the hopper.

The flexible end or joint of the beam compensates for any difference that may exist in the length of the cranks, as well as for the purpose of allowing the beam being detached at that point, in order to turn it over clear of the hopper, as hereinbefore set forth.

The machine is operated by a crank, Y, secured to the master cog-wheel G. The fly-wheel Z on the back end of the shaft, to which the beam is secured by a rigid joint, is provided with a counter-weight, arranged to counterbalance the weight of the beam and prevent any tendency to shake the machine.

The construction and arrangement shown in Fig. 5, which are a modification of that shown in Fig. 2, may be used, if desired. In this case the master cog-wheel and its connecting-pinions are not used. The cranks are kept in their relative position by bevel-pinions *d* and an additional shaft, *e*, arranged at right angles with the crank-shafts *f*. The beam *g*, to which the knives are secured, may be forked, as shown, in order to obviate increased friction by any lateral pressure caused by resistance offered to the mincing-knives, or from other reasons. The crank-shafts may each be provided with a fly-wheel, and a pulley connecting by a suitable belt with any convenient motor used in place of the hand-crank Y to operate the machine.

The operation is as follows: The knives are set in motion by the pinions F, which gear with the master-wheel G, arranged on the stud

H. At the same time the pinion I, rigidly secured to said stud H and interposed between the master-wheel G and frame A, sets in motion the cog-wheel J on the shaft K, which, in turn, operates the bevel-pinion M. The hopper receives its motion by the circular gear N on the bottom of the block Q, with which the teeth of the pinion M meshes.

As the block revolves, the knives, on their downward movement, cut from close up to the side of the hopper outwardly. It is understood that the knives move with such rapidity as to cut the meat into particles of the required size.

The extended movement of the knives in the direction of their length, when near the block, will cut the toughest meat without being forced into the block, thereby obviating any mutilating of the block, which necessarily dulls the knives, and providing a superior machine of less bulk and weight, both of which latter exist in old-style meat-choppers.

Having thus fully described my invention, what I claim as new, and desire to secure by Letters Patent, is—

1. The beam S, in combination with the crank-shafts D D, said parts being constructed and operating substantially as shown and described, and for the purpose set forth.

2. The master cog-wheel G, in combination with the pinions F F, crank-shafts D D, and beam S, said parts being constructed and operating substantially as shown and described, and for the purpose specified.

3. The flexible joint X and rigid joint W, in combination with the beam S, substantially as shown and described, and for the purpose specified.

In testimony that I claim the foregoing as my own I affix my signature in presence of two witnesses.

EDWARD W. FAWCETT.

Witnesses:

J. G. DUCK,  
JAMES R. CAREY.