

D. H. KING.  
Newspaper-File.

No. 204,233.

Patented May 28, 1878.

*Fig: 1.*

*Fig: 2.*

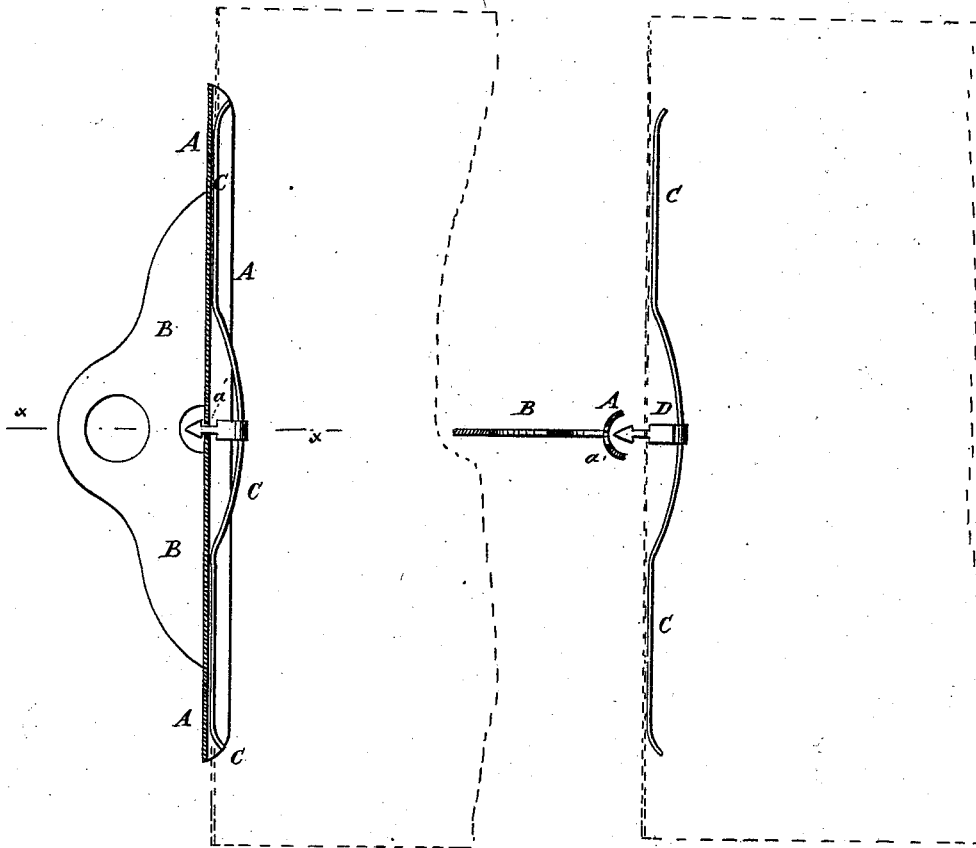

*Fig: 3.*

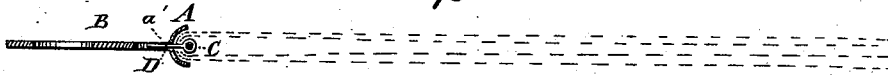

*Fig: 4.*



WITNESSES:

*Chas. Nicola*  
*C. Sedgwick*

INVENTOR:

*D. H. King*  
BY *Munn & Co*

ATTORNEYS.

# UNITED STATES PATENT OFFICE.

DAVID H. KING, OF NEW YORK, N. Y.

## IMPROVEMENT IN NEWSPAPER-FILES.

Specification forming part of Letters Patent No. **204,233**, dated May 28, 1878; application filed April 30, 1878.

*To all whom it may concern:*

Be it known that I, DAVID HANNA KING, of the city, county, and State of New York, have invented a new and useful Improvement in Paper-Files, of which the following is a specification:

Figure 1 is a side view, partly in section, of my improved paper-file. Fig. 2 is the same view as Fig. 1, but showing the upper part of the file turned one-quarter around and sectioned through its center. Fig. 3 is a cross-section of the same, taken through the line *xx*, Fig. 1. Fig. 4 is a detail view of the under side of the upper part of the file.

Similar letters of reference indicate corresponding parts.

The object of this invention is to furnish an improved device for securing the parts of a paper or several papers together in such a way that they may be conveniently handled and read without getting out of place, and which, at the same time, may furnish a means for hanging them up, if desired.

The invention consists in the combination of the semi-tubular plate, provided with a handle and a cross-slit in its center, the wire spring, and the steel needle, provided with an arrow-head, as hereinafter fully described.

A represents the outer part of my improved device, which is made semi-tubular in form, and has a short cross-slit, *a'*, formed in its center.

To the outer side of the plate A is attached a flange plate or handle, B, which is cut out in the central part of its lower edge over the slit *a'*, and has a hole formed through the middle outer part to enable it to be hung upon a hook or other support.

C is a spring-wire, the end parts of which are straight and in line with each other, and

its middle part is curved downward, as shown in Figs. 1 and 2.

To the center of the wire C is attached a needle, D, which is made with an arrow-shaped head of such a size as to pass through the slit *a'* of the plate A.

In using the device, the spring-wire C is placed within the fold of the paper or papers to be secured, and the needle D is pressed through the said papers in the line of the said fold. The outer part A is then turned at right angles with the spring-wire C, as shown in Fig. 2, and pressed downward until the head of the needle D has passed through the slit *a'* of the said plate A. The plate A is then turned parallel with the spring-wire C, the end parts of said spring-wire pressing the fold of the paper or papers into the cavity of the said part A, and the shoulders of the needle-head resting upon the outer side of the plate A, at the opposite sides of its slit *a'*, to hold the parts of the file securely in place, clamping the paper between them.

With this construction the papers may be readily secured and released when desired, and when secured will be held firmly in place.

Having thus described my invention, I claim as new and desire to secure by Letters Patent—

The combination of the semi-tubular plate A, provided with a handle, B, and a cross-slit, *a'*, in its center, the wire spring C, and the steel needle D, provided with an arrow-head, substantially as herein shown and described.

DAVID H. KING.

Witnesses:

JAMES T. GRAHAM,  
C. SEDGWICK.