

P. S. KEMON.  
Furnace-Door.

No. 204,339.

Patented May 28, 1878.

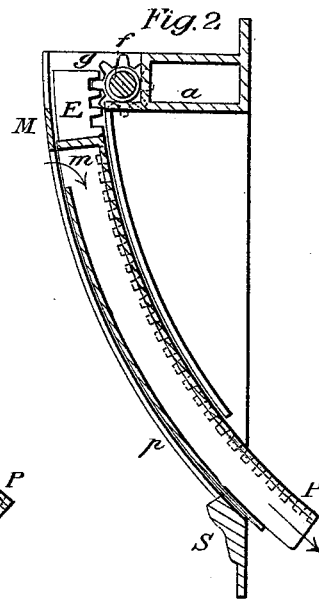
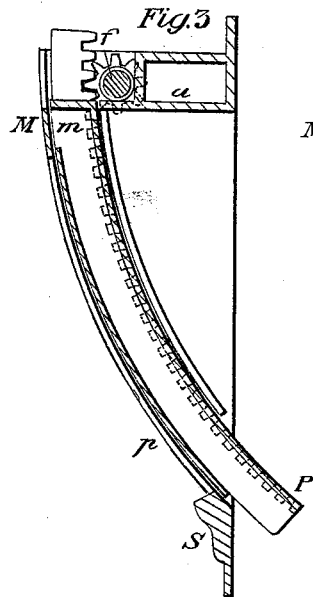
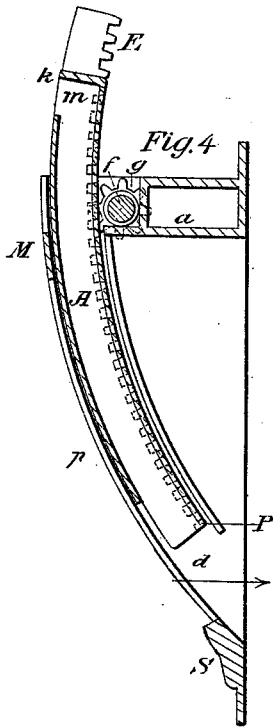
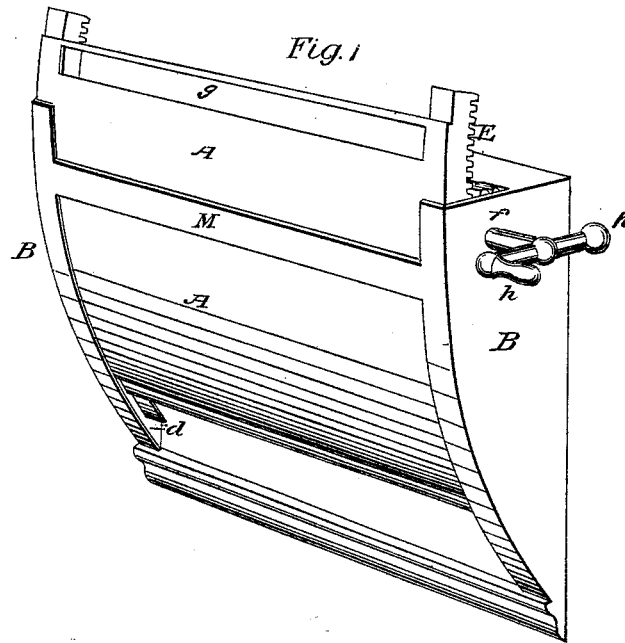

Attest

*John Kemon*  
*Chas. A. Pettit*

Inventor

*P. S. Kemon*  
By *Victor Hobassa*

# UNITED STATES PATENT OFFICE.

PETER S. KEMON, OF WASHINGTON, DISTRICT OF COLUMBIA.

## IMPROVEMENT IN FURNACE-DOORS.

Specification forming part of Letters Patent No. **204,339**, dated May 28, 1878; application filed April 4, 1878.

*To all whom it may concern:*

Be it known that I, PETER SOPHOCLES KEMON, of Washington city, in the county of Washington, District of Columbia, have invented certain new and useful Improvements in Furnace-Doors; and do hereby declare that the following is a full, clear, and exact description of my invention, which will enable others skilled in the art to which it pertains to make and use the same, reference being had to the accompanying drawing, and to the letters of reference marked thereon, which form a part of this specification.

The object of my invention is to construct and arrange a furnace-door in such a way as to make it capable of admitting heated air directly to the upper strata of the incandescent fuel, and at the same time to arrange the door in such a way as to make it capable of being partially opened upward for the purpose of slicing the fire.

The nature of my invention consists in the construction of a hollow-walled door moving upward and downward, and so arranged as to be capable of being held in any adjustment at any required height without being counter-balanced by weights.

Further, the nature of my invention consists in the constructing of a port or slot on the upper part of the door, said slot being capable of tight closure by a horizontal bridge bar or plate, the said port or slot with the closing horizontal bar to form a regulator for the admission of air into the furnace.

Finally, my invention consists in making the inner door-plate project downward below the outer door-plate, so as to form a deflector for the admitted air.

I will now proceed to describe the construction and the operation of my furnace-door.

Figure 1 represents a perspective view of my door partially opened and held in position for the purpose of slicing the fire. Fig. 2 represents a vertical section, showing the door lowered sufficiently to permit the admission of air through the upper slot or port. Fig. 3 is a vertical section, showing the door closed, so as to cut off the induction of air. Fig. 4 is a vertical section, showing the door in the same position as in Fig. 1.

The casing of the furnace-door A has the

usual rectangular form, but the top bar or crown-piece *a* is extended forward, and vertical parallel guides B B project from the door-casing. These guides may have various forms or outlines, but I prefer to make them curved on the front edge from the bottom to the top, where they are widest. Each guide is provided with a groove, *d*, on its inner side contiguous and parallel to its front edge, and of suitable depth to receive the ends of the door A—that is to say, the side edges enter the grooves *d d* in the guides B, and the door is thus adapted to move therein and be adjusted vertically, or nearly so, by means of any suitable device. I show as a means for effecting such adjustment rack-bars E affixed or formed solid with the respective ends of the door, and a rotary shaft, *f*, having its bearings in the guides B B and provided with pinions *g*, which mesh with said rack-bars. A crank or handle, *h*, is fixed on one end of the shaft for rotating it in either direction for raising or lowering the door, and in case it should be required a spring or other device may be employed to increase the friction of the pinion-shaft, and hold the latter fixed in any position to which it may be adjusted. The aforesaid rack-bars E are of the same width as the thickness of the door, and are inclosed in the grooves or channels *d* of the guides B.

I will now proceed to describe the construction of my door with reference to regulating the admission of air and directing it into the furnace-chamber. The door A, in place of being open on the top or upper side, has a cap, *k*, and is provided with a narrow port or slot, *m*, extending along the front close to the upper edge.

A bridge bar or plate, M, whose width somewhat exceeds that of the port or slot *m*, connects the upper ends of the guides B B, and is arranged to fit snugly against the upper slotted portion of the door when the latter is lowered. It will be seen that by adjusting the door A as in Fig. 3, so that the bridge-plate M completely covers the opening *m*, the admission of air to the furnace through the door A is entirely cut off; but by adjusting said door downward, as in Fig. 2, so that the slot or opening *m* is uncovered, the air has free admission, and, being heated in its pass-

age through the door, it enters the furnace in that condition, and, mingling with the gases evolved from the upper strata of the incandescent coal, thereby promotes their combustion, as well as that of the carbon particles constantly rising from the coal, which gases and carbon particles would otherwise escape unburned into the chimney, which two primary effects produce the desired ultimate effect—that is, a more economical consumption of fuel.

Aside from the hereinbefore-mentioned advantages derived from this arrangement of the door A to move in curved or inclined guides, as above specified, this is of particular importance, namely: that I am enabled to extend downward the inner plate P of the door, so that when the door is adjusted with its outer plate *p* resting on and projecting beyond the door-sill S, as shown in Fig. 2, said plate P projects downward past the sill S, and thereby constitutes a deflector, which directs the air-current downward on the upper stratum of the incandescent fuel, where the combustion of the escaping gases, through lack of oxygen, is generally defective.

The projecting plate P would be of great use and particularly adapted for furnaces where the grate-bars are placed at a considerable depth or distance below the door-sill—as, for instance, in furnaces of locomotive-boilers.

The projecting part of the inner door-plate P can be made of a separate piece of metal, attached with screws to the inner plate of the door A, so as to be easily replaced should it be burned out after a prolonged use. When the fire requires to be sliced—that is to say, when the crust formed on the body of coal in the furnace requires to be broken up—the door A is raised, as in Figs. 1 and 4, in which position a sufficient space is left beneath it for the introduction and manipulation of the slice-bar; but the door still closes the greatest part of the space or opening inclosed by the door-casing, and thus forms a protection to the crown or fire-sheet and tube-sheet of boilers by preventing the too sudden flow of large volumes of cold air against the same, which

oxidizes the iron and causes it to become incompetent to withstand the pressure of steam in the boiler, and which is the cause of frequent boiler-explosions, as engineers well know.

The door, thus partially opened for the purpose of slicing the fire, affords a very desirable protection to the fireman against the effects of the excessive heat to which he would be subjected with the use of doors operated in the usual way—that is, opening sidewise, on hinges or otherwise. These advantages attend the introduction of fuel into the fire-box, and are obviously incidental to raising the door for momentary inspection of the fire or for other purposes.

Having thus described my invention, what I claim as new, and desire to secure by Letters Patent, is—

1. A double-walled or hollow furnace-door open at top and bottom, arranged to slide upward and downward, and in relation to the sill of the door-frame, in the manner described, whereby it is adapted to be adjusted so as to pass over the door-sill and project into the furnace-chamber, as specified.

2. A double-walled or hollow furnace-door open at top and bottom, and arranged to slide upward and downward, and having its inner plate extended downward below the outer plate, for the purpose of deflecting the air-current, in the manner specified.

3. A double or hollow-walled sliding furnace-door open at the bottom and on its front side near the top, in combination with the stationary bridge-plate and lateral guides, substantially as described, whereby the admission of air through the door downward into the front of the fire-box is controlled by adjustment of the door with relation to the bridge-plate, as specified.

In testimony that I claim the foregoing as my own I hereto affix my signature in presence of two witnesses.

PETER SOPHOCLES KEMON.

Witnesses:

SOLON C. KEMON,  
CHAS. A. PETTIT.