

M. J. MATTHEWS.  
 Mechanical Musical Instrument.

No. 204,352.

Patented May 28, 1878.

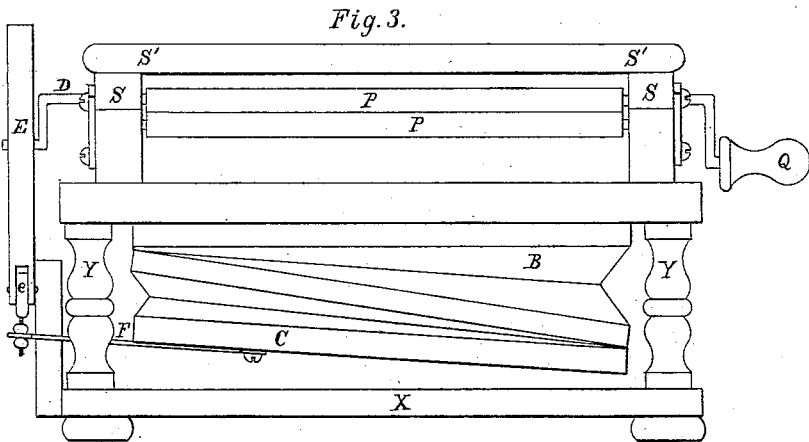
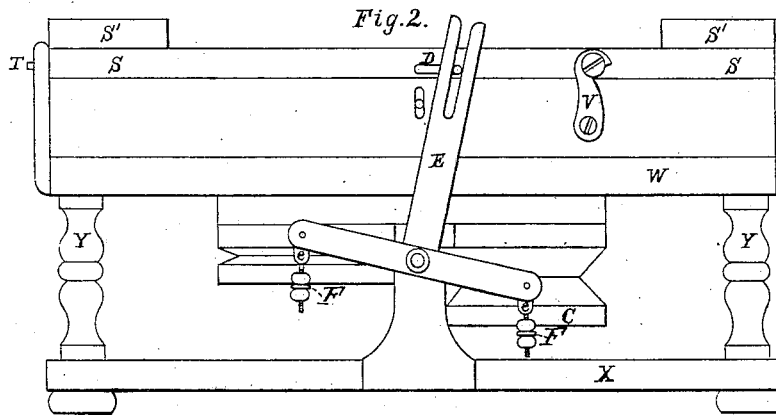
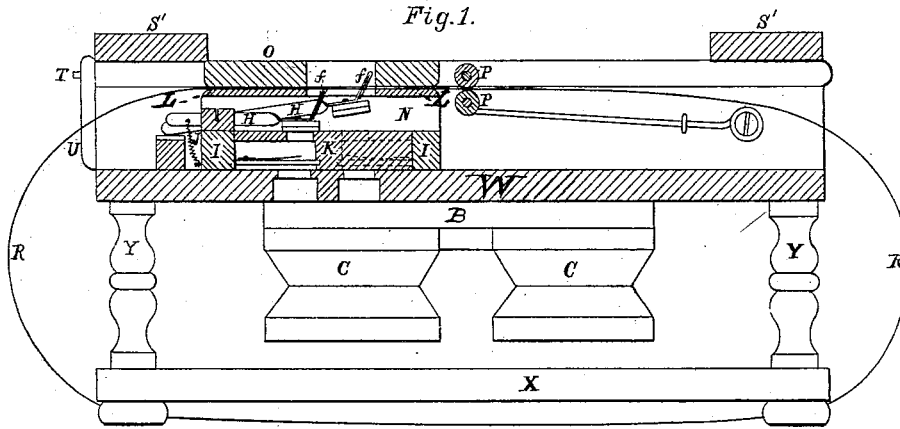

Witnesses:  
 Robert W. Matthews.  
 Geo. A. Darling

Inventor:  
 M. J. Matthews

# UNITED STATES PATENT OFFICE.

MASON J. MATTHEWS, OF BOSTON, MASSACHUSETTS.

## IMPROVEMENT IN MECHANICAL MUSICAL INSTRUMENTS.

Specification forming part of Letters Patent No. 204,352, dated May 28, 1878; application filed December 11, 1877.

### *To all whom it may concern:*

Be it known that I, MASON J. MATTHEWS, of Boston, in the State of Massachusetts, have invented a new and useful Improvement in Mechanical Musical Instruments, which improvement is fully set forth in the following specification, of which the accompanying drawings form a part.

My invention relates to mechanical wind-instruments in which perforated paper is used to produce music automatically.

It consists in the arrangement of a series of valves directly between a corresponding series of air-passages to reeds and a perforated sheet of paper, in such a manner that the paper, as it is caused to pass along, shall hold the whole series of valves to their seat or bed, excepting at such intervals as are determined by the position and length of the perforations in the paper, and their relation to their corresponding valves.

It further consists in a compactly-constructed bellows, and of a simple and novel means of operating them.

It also consists in such a form of construction as provides for the easy removal of the sheets of paper when a change of tune is desired.

Figure 1 is a sectional elevation of one of the sides of my instrument, representing the reed-board, chamber-cap, pressure-cap, and bellows. Fig. 2 is an elevation of one side of my instrument, representing the manner in which the bellows are operated. Fig. 3 is an elevation of one of its ends with the music removed.

B is the reservoir; C C, the feeders. The reservoir B is mounted on the under face of the platform W. The feeders C C are mounted on the lower board of the reservoir B. This is a simple and compact form of construction, involving the employment of the least possible space, and requiring no supplementary wind-chest, such as is ordinarily employed in reed-instruments.

The feeders C C are operated by the crank D through the medium of the three-armed lever E, the toggles e, and the wire projections F. As the bellows and the music-sheet are both operated by the same handle, it is necessary that some provision be made to pre-

vent the jerking that would be consequent upon a continuous turning of the handle when the reservoir is exhausted. This is secured in the wire projections F.

The tube-board is constructed similar to that of a key-board cabinet-organ, the main difference being that the tubes are not directly opposite each other, but are arranged and located so that the tubes of one row are opposite the partitions between the tubes of the other row. The reeds are inserted in these tubes in alternate succession, each consecutive reed in the scale being in a different row.

The object of this arrangement is to bring the push-points *ff* of the valves H H as close together as is practicable, so that there may be used a narrower sheet of paper than would be necessary for the same number of reeds if they were all located in one row. The mouths of the tubes are closed by the strips I I, and a hole is made through the tubes directly over the reeds. These holes are controlled by the valves H H. The springs J tend to keep the valves H H away from their seat. Screwed or otherwise fastened to the top of the tube-board K is a chamber-cap, L. The valves are all mounted within the chamber N.

Through the top of the chamber-cap L are a series of holes corresponding to the push-points *ff* of the valves H H. There is also a series of holes through the pressure-cap O, corresponding to the series of holes through the chamber-cap L. The pressure-cap O is held down by a spring of sufficient strength to resist the force of the springs J. The perforated sheet is inserted between the pressure-cap O and the chamber-cap L, and between the friction-rollers P P, so that when the handle Q is turned the rollers P P draw the perforated sheet R along and over the push-points *ff* of the valves H H, and thus hold them closely to their seats, excepting at intervals provided for by the perforations. The exhaust power of the bellows, combined with the perforated sheet, keeps the valves on their seats. The springs J are little more than strong enough to resist the wind force exerted on the valves H H, so that the friction of the push-points *f* on the perforated sheet is very slight.

The two ends of the perforated sheet R are joined together, so as to form a continuous

band or roll, passing over the chamber-cap L around each end and between the feet of the instrument.

Provision for facilitating the mounting and removal of the perforated sheet R is made in the movable guide-rails S. In one end of each guide-rail S is a stud, T. This stud T passes into a hole in the holder U. The other end of each guide-rail is held down by a hook, V. The guide-rails S are held together by the cross-rails S', so that the whole forms an easily-handled frame. Between the platform W, upon which the main parts of the instrument are mounted, and the base-board X are pillars Y, so that the bellows and action which operates them are exposed to view. The case may be of any suitable design.

The base-board X might be dispensed with, and the action might be supported on turned legs. Instead of the turned pillars, square posts might be used, and wire-gauze, neatly stenciled, might be stretched around them, so as to cover in all sides and conceal the bellows; or the whole action might be incased in wood.

The bellows might be mounted so that their movements would be parallel with the sides of the instrument, or in any other desirable position, so that they might be operated by pulleys and cord in connection with a crank, or by friction-pulleys and crank; or they might be operated by a rocking shaft mounted below the feeders and connected with the crank.

The tube-board might be constructed so that the reeds inserted therein would stand in a vertical position and the valves rest on the mouths of the tubes, instead of as shown.

The valves H H may be made of either metal or wood, and they may be hinged with leather or other suitable material.

I am aware that perforated paper has been

used in connection with valves and levers, so that I do not claim the mere combination of such sheets with valves, nor with levers and valves; but

What I claim, and desire to secure by Letters Patent, is —

1. In combination with reeds and their air-passages, and a perforated sheet of paper, a series of valves, constructed and arranged to be held to their seat or bed by the combined action of the said perforated sheet and pneumatic pressure, substantially as described and shown.

2. In combination with reeds and their air-passages, together with a series of valves, H H, constructed substantially as described, a continuous roll of perforated paper, all as and for the purpose set forth.

3. The combination and arrangement of the friction-rollers P P and three-armed lever E with the adjustable toggles e and feeders C C, when constructed and arranged substantially as described.

4. The combination of the friction-rollers P P and perforated paper R with the valves H H, substantially as set forth.

5. In combination with an endless sheet of perforated paper and the valves H H, the removable guide-rails S, substantially as and for the purpose specified.

6. In a mechanical musical wind-instrument having reeds and an endless band or sheet of paper, suitably perforated to produce a tune in connection with valves, the reeds arranged in alternate positions in two rows, substantially as specified.

MASON J. MATTHEWS.

Witnesses:

N. C. LOMBARD,  
E. A. HEMMENWAY.