

E. BALDWIN, Jr.
Ash-Sifter.

No. 204,474.

Patented June 4, 1878.

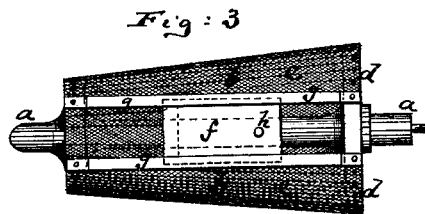
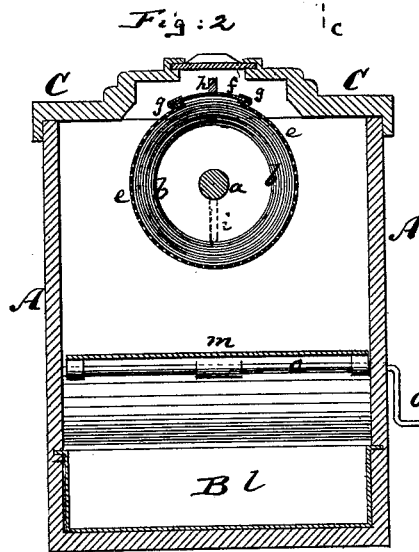
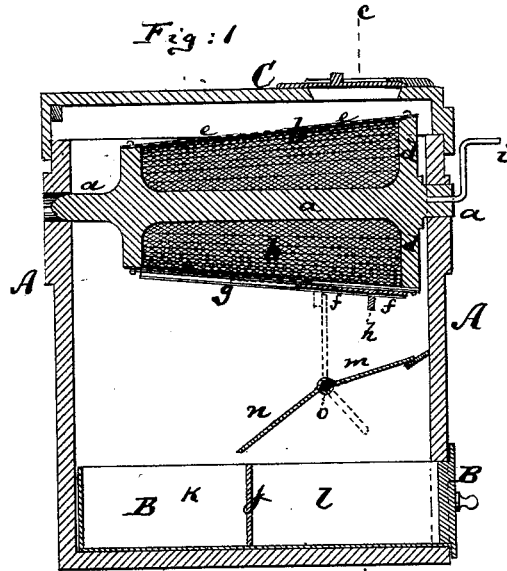

Witnesses:
A. Briesen
T. B. Mosher

Inventor:
E. Baldwin Jr.
by his attorney
A. Briesen

UNITED STATES PATENT OFFICE.

EDWARD BALDWIN, JR., OF NEW YORK, N. Y.

IMPROVEMENT IN ASH-SIFTERS.

Specification forming part of Letters Patent No. **204,474**, dated June 4, 1878; application filed April 11, 1878.

To all whom it may concern:

Be it known that I, EDWARD BALDWIN, Jr., of New York city, in the county of New York, State of New York, have invented an Improved Ash-Sifter, of which the following is a specification:

This invention relates to an improved ash-sifter which will readily separate the ashes and coal and discharge them into separate receptacles.

The invention consists of the details of improvement hereinafter more fully pointed out.

In the accompanying drawing, Figure 1 represents a vertical longitudinal central section of my improved ash-sifter. Fig. 2 is a vertical transverse section thereof on the line *c c*, Fig. 1. Fig. 3 is a detail face view of the sieve.

Similar letters of reference indicate corresponding parts in all the figures.

The letter *A* represents a box of suitable form and size. In the upper part of the box are the bearings of the axle *a* of a revolving drum, *b*. This drum *b* is made of truncated conical form, closed at its two ends by wooden or other disks or heads, and surrounded at its circumference by a suitable wire or other perforated screen, *e*, which is attached to said disks. At one part of its circumference the wire screen has an opening for the introduction of the ashes and coal to be sifted. This opening is situated near the larger disk *d*, and may be closed by a cover, *f*, that slides between two parallel rails or guides, *g g*, fastened to the disks, as clearly shown in Fig. 3.

To the cover *f*, and near to the disk *d*, is rigidly secured an outwardly-projecting pin or handle, *h*, by which the cover *f* can be opened and closed, and which serves the additional purpose hereinafter pointed out.

The drum *b* may be revolved by a crank, *i*, projecting beyond the box *A*, as shown.

Into the lower part of the box *A* is inserted a drawer, *B*, that covers the bottom of the box *A*. This drawer is, by a central partition, *j*, that is placed at right angles to the axle *a*, divided into two preferably equal

compartments, *k* and *l*, as shown. Instead of using one drawer, *B*, two drawers may be used, each being of the size of one of the compartments *k l*, and inserted at opposite sides of the box *A*.

The compartment *l* is closed on top by an inclined shield or cover, which extends across the box *A*, and is made in two parts, *m* and *n*, said parts being connected by a hinge. The plate *m* is movable, being connected to a crank-axle, *o*, by which it can be swung up or down; but the plate *n* is rigidly secured in the box. The cover *m n* may, however, also be made in one piece, hinged above the partition *j*.

It will be seen that, when the cover *m* is swung up, matter can be discharged from the sieve into the compartment *l*. When, however, the cover *m* is closed down, all matter falling through the sieve will fall into the compartment *k*. The cover *m* is hung at such a distance below the drum *b* that, when it is swung from its closed into its open position, (indicated by dotted line in Fig. 1,) it will strike the pin *h* of the slide *f* when such slide is in its lowermost position, and thereby move said slide open.

The operation of the apparatus is very simple. The mixed ashes and coal to be sieved are introduced into the drum *b* through the opening in the wire screen, which is then closed by the sliding cover *f*. The drum *b* is next revolved by means of the crank *i*, and (the cover *m* being closed) the ashes will all fall into the compartment *k* of the drawer *B*. The coal will settle near the larger disk *d* in the drum *b*, owing to the conical form of the drum. After the ashes have been removed, the drum *b* is swung into such a position that the sliding cover *f* is at the bottom, as in Fig. 1. The cover *m* is then swung open, so that it will strike the pin *h* and cause the cover *f* to slide upward, thereby opening the aperture in the screen *e* that had been closed by said cover *f*. The coal will now fall through the aperture into the compartment *l*, and be properly separated from the ashes.

The box *A* has a suitable cover, *C*, to prevent the dust from escaping during the sifting operation.

I claim—

1. The combination of the box *A* with the drum *b*, made of truncated conical form, and provided with the sliding cover *f*, having pin *h*, substantially as specified.

2. The combination of the box *A* with the

drum *b*, having the sliding cover *f* and pin *h*, and with the compartments *k* and *l* and hinged cover *m*, all being so arranged that by swinging the cover *m* upward the slide *f* may be opened, substantially as specified.

EDWARD BALDWIN, JR.

Witnesses:

A. V. BRIESEN,

T. B. MOSHER.