

E. BOURNE.
Riveting Device.

No. 204,476.

Patented June 4, 1878.

Fig. 1.

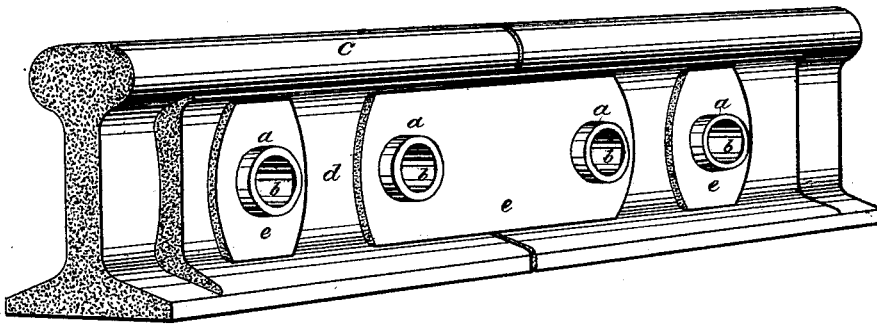
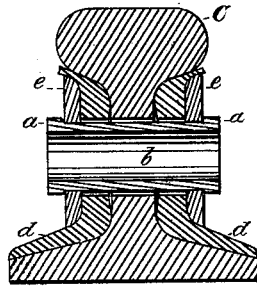

Fig. 2.



WITNESSES:

Jonathan Ord.
Alfred S. Tracy

INVENTOR

Edward Bourne.
by Josiah W. Eddy
ATTORNEY

E. BOURNE.
Riveting Device.

No. 204,476.

Patented June 4, 1878.

Fig. 3.

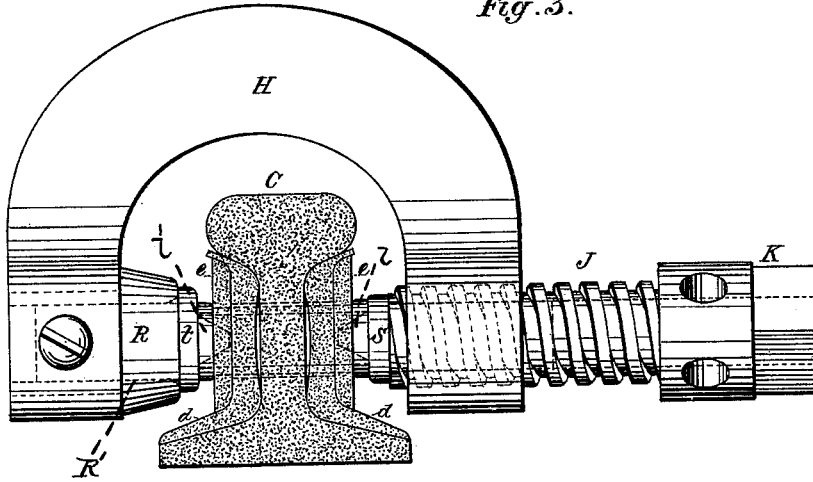
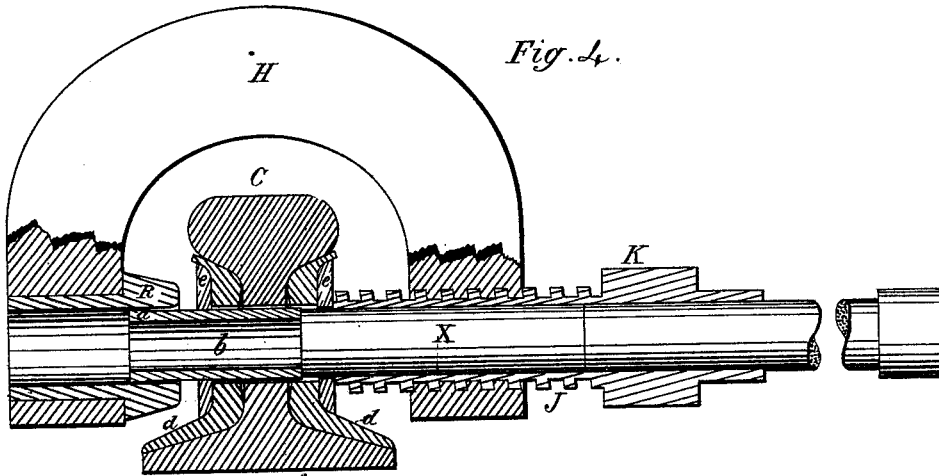

Fig. 4.



WITNESSES:

Jonathan Ord.
Alfred S. Tracy

INVENTOR

Edward Bourne.

By Josiah W. Ellis

ATTORNEY

UNITED STATES PATENT OFFICE.

EDWARD BOURNE, OF PITTSBURG, PENNSYLVANIA.

IMPROVEMENT IN RIVETING DEVICES.

Specification forming part of Letters Patent No. 204,476, dated June 4, 1878; application filed February 18, 1878.

To all whom it may concern:

Be it known that I, EDWARD BOURNE, of Pittsburg, in the county of Allegheny and State of Pennsylvania, have made a new and useful Machine for Enlarging the Ends of Tubular Rivets upon Fish-Bars, which will be readily understood from the following description, taken in connection with the accompanying drawings, wherein—

Figure 1 represents a perspective view of two railway-rails joined together by means of fish-bars and tubular rivets; Fig. 2, a transverse vertical section of one of said rails with the splice-plate, washers, and tubular rivet; Fig. 3, an end elevation of one of the rails, and therewith the implement for enlarging the ends of the tubular rivet; Fig. 4, a sectional view of a railway-rail, the splice-plate, rivet, and implement for unfastening and releasing said rivets.

Heretofore all tubular rivets used in uniting material objects have for that purpose their ends spread or flared out, so as to form thereon a sort of hollow conical head or flange, similar to the ordinary eyelet. Where a mere union of parts is wanted, the flaring tubular rivet will answer that end; but when once placed, the difficulty of withdrawal makes it, for some purposes, very objectionable.

By my invention a head, *a*, is formed on both ends of the tubular rivet *b* at one and the same time, and of such a character as not only makes a better and more substantial head than when flared, but, if necessary, admits of certain and ready removal, as occasion may require.

The rail *c*, splice-plates *d d*, and washers *e e* may be of such forms as are most generally used. To unite these splice-plates firmly to the rails, and thereby form as near as may be a perfect joint, I make use of a tubular rivet, *b*, instead of the ordinary screw-bolt and nut. These rivets are to be of such a length as that their ends will project about half an inch when placed in the holes through the splice-plates, rails, and washers, and thick enough to withstand successfully the "settling-down" process, presently described. As soon as a rivet, *b*, is placed in proper position, so much of its ends as project beyond and outside of the splice-plates are, by means of my machine, formed

into a square shoulder next and against each splice-plate *d* or washer *e*, as the case may be, without enlarging the diameter of the interior of tube. To accomplish this I stave, by compression, the projecting ends of these rivets, and to that end make use of a strong metallic U-shaped clamp, *H*, the extremities of which are just far enough apart to answer the purposes of its construction. Through one end of this clamp passes a hollow, but very powerful, screw, *J*, on the outer end *K* of which provision is made for turning it by means of a wrench or rod, as in other contrivances of a similar sort. In the hollow of the opposite end of this screw is placed a steel tool, *l*, furnished with a conical projection, as shown in dotted lines, Fig. 3, the largest diameter of which just equals the size of the hole through the tubular rivet intended to be operated on. Immediately around the point of its largest conical diameter the tool is encircled by a collar or flange, *S*, in width a little more than the thickness of the tubular rivet. Supported by the other leg of the U-shaped clamp *H*, and on the same axial line, is arranged a hollow seat, *R*, as shown more clearly in Fig. 4; and within this seat I secure a tool composed of a short rod, as indicated by dotted lines *R'*, Fig. 3, the same having a collar, *t*, and a conical end or mandrel, *v*, (also shown by dotted lines, Fig. 3,) said mandrel corresponding in size and form to the conical mandrel *l* upon the opposite end of the U-shaped bar *H*.

On the application of a long lever to the screw a powerful pressure may be brought to bear on both ends of the rivet simultaneously, sufficient to crush, stave up, and thicken the projecting ends, so as to form a head thereon, and that without flaring or spreading its central bore. Thus each rivet may be fastened in regular successive order.

In case it should become necessary to remove a rivet, the conically-pointed tools are to be taken out of the clamp, so that on the application of the clamp to the rivet it will be found that the hollow of the screw will fit over one end of the rivet, and the hollow of the seat *R* in the opposite leg of the clamp over the other end of the rivet, and when screwed tightly down, on the insertion of a flat or square ended steel rod or drift, *X*, in the hollow of the screw,

the rivet may be, by a few sharp blows, driven entirely out.

I claim—

As a mechanism for enlarging the ends of tubular rivets upon fish-bars, the U-shaped bar H, in combination with the conical-shaped mandrel *l*, with collar S, and secured in place by a connecting-rod within the hollow screw

J, and also the mandrel *l'*, of conical form, the collar *t*, and suitable rod or shank thereof, secured in the hollow collar R, substantially as shown and described.

EDWARD BOURNE.

Witnesses:

JOSIAH W. ELLS,
ROBERT S. SILL.