

# G. W. GRIMES. Combined Drill and Planter.

No. 204,488.

Patented June 4, 1878.

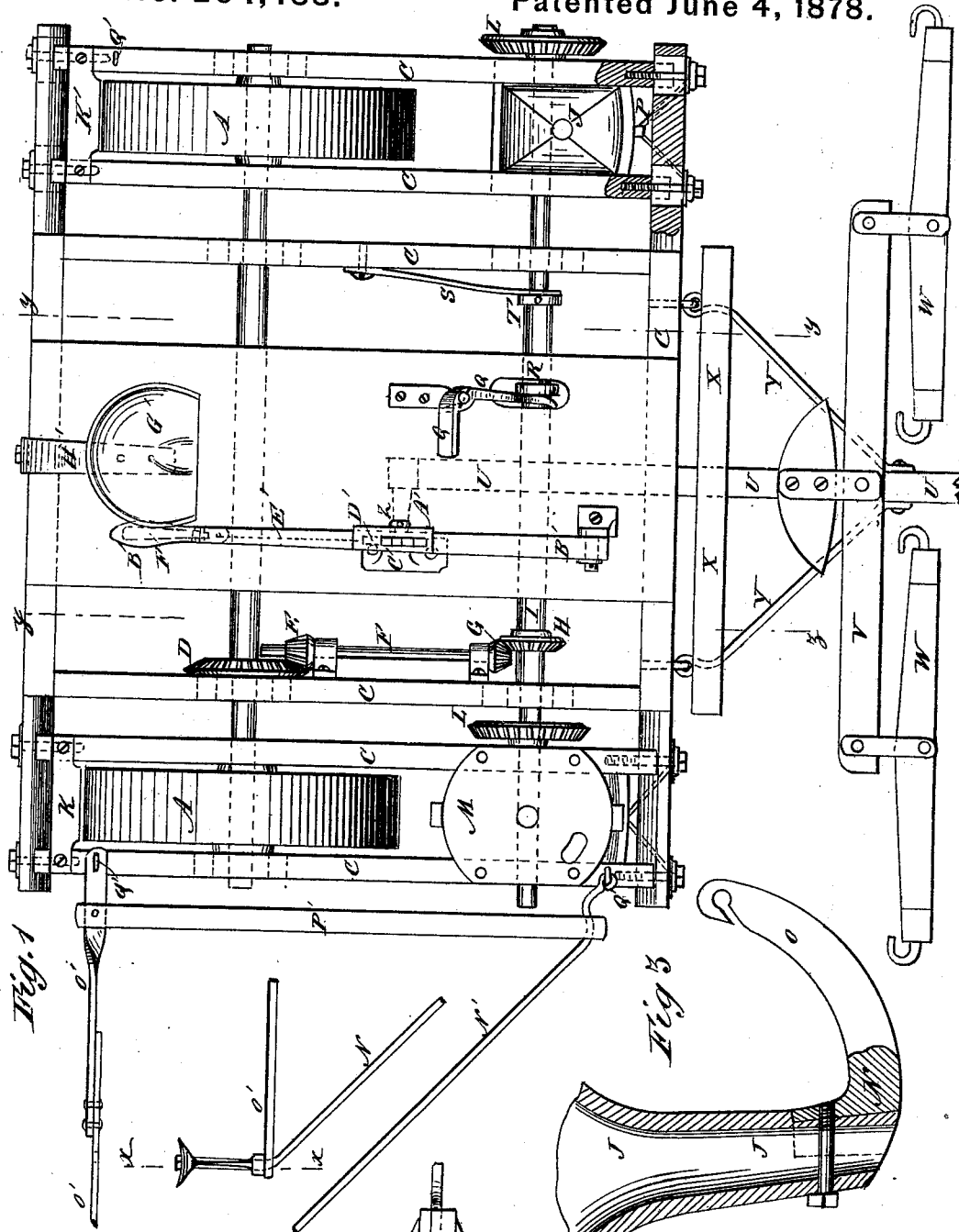

Fig. 1

Fig. 2

Fig. 3

WITNESSES:  
*C. Nevada*  
*C. Sedgwick*

INVENTOR:  
*G. W. Grimes*  
 BY *Munroe*  
 ATTORNEYS.

G. W. GRIMES.  
Combined Drill and Planter.

No. 204 488.

Patented June 4, 1878.  
*Fig. 4*

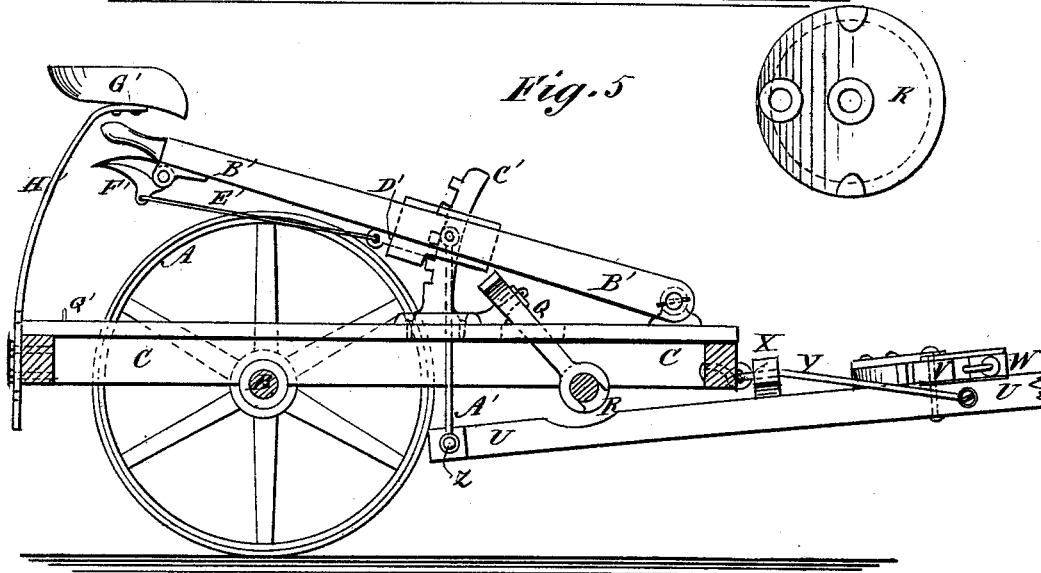
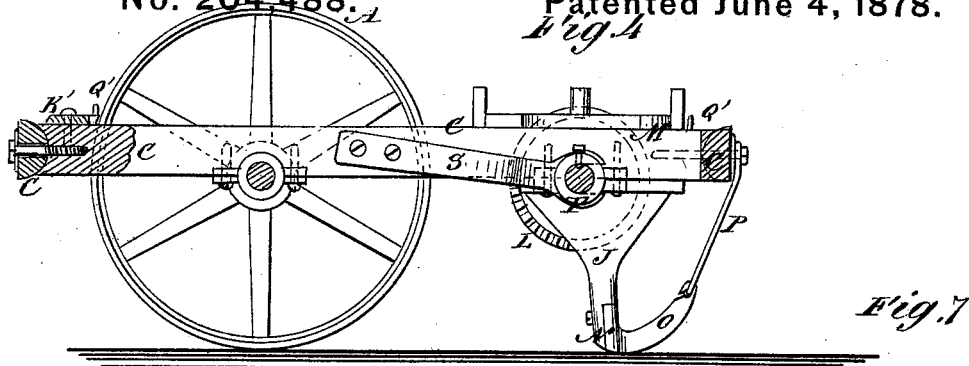

*Fig. 6*

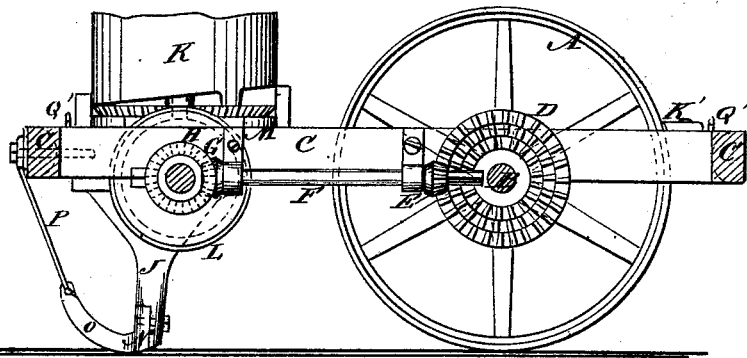

WITNESSES:

*C. Newell*  
*C. Sedgwick*

INVENTOR:

*G. W. Grimes*  
BY *Munn & Co.*

ATTORNEYS.

G. W. GRIMES.  
Combined Drill and Planter.

No. 204,488.

Patented June 4, 1878.

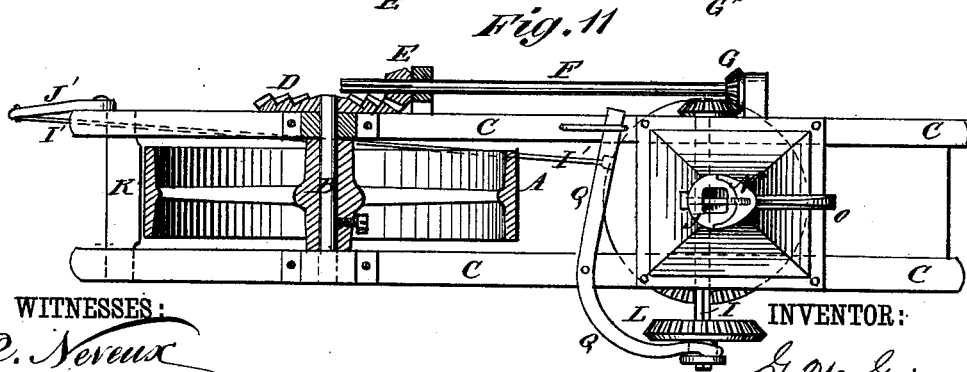
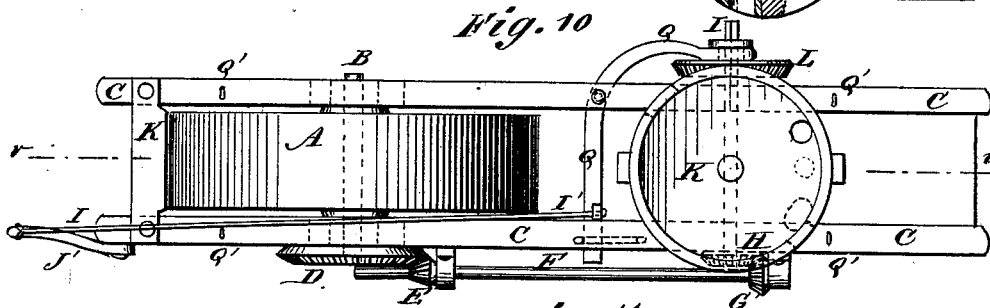
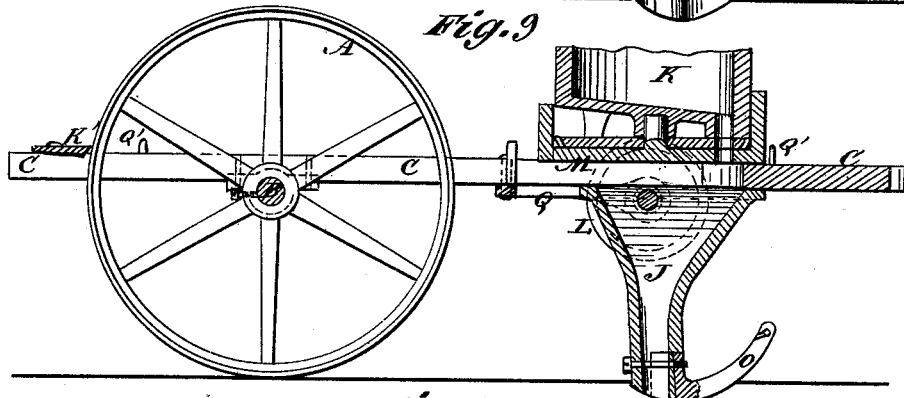
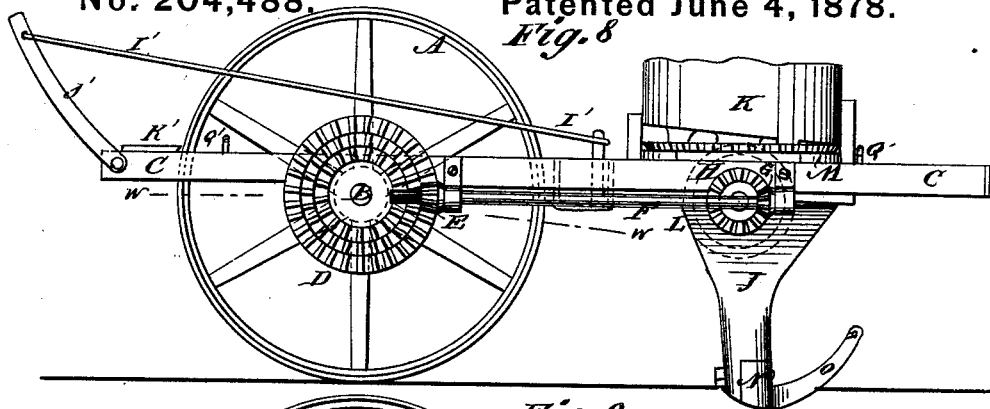

WITNESSES:  
*C. Neveu*  
*C. Sedgwick*

INVENTOR:  
*G. W. Grimes*  
 BY *Munroe*

ATTORNEYS.

# UNITED STATES PATENT OFFICE.

GEORGE WASHINGTON GRIMES, OF BLUFFTON, INDIANA.

## IMPROVEMENT IN COMBINED DRILL AND PLANter.

Specification forming part of Letters Patent No. 204,488, dated June 4, 1878; application filed March 26, 1878.

*To all whom it may concern:*

Be it known that I, GEORGE W. GRIMES, of Bluffton, in the county of Wells and State of Indiana, have invented a new and Improved Combined Drill and Planter, of which the following is a specification:

Figure 1, Sheet 1, is a top view of my improved machine, part being removed to show the construction. Fig. 2, Sheet 1, is a detailed section taken through the line *x x*, Fig. 1. Fig. 3, Sheet 1, is a detailed section of the conductor-spout and foot. Fig. 4, Sheet 2, is a longitudinal section of the machine, taken through the line *y y*, Fig. 1. Fig. 5, Sheet 2, is a longitudinal section of the same, taken through the line *z z*, Fig. 1. Fig. 6, Sheet 2, is the same section as Fig. 5, but looking to the left. Fig. 7, Sheet 2, is a detailed bottom view of the hopper. Fig. 8, Sheet 3, is a side view of a modified form of the same. Fig. 9, Sheet 3, is a longitudinal section taken through the line *v v*, Fig. 10. Fig. 10, Sheet 3, is a top view of the same. Fig. 11, Sheet 3, is a bottom view of the same, partly in section, through the line *w w*, Fig. 8.

Similar letters of reference indicate corresponding parts.

The object of this invention is to improve the construction of the machine for which Letters Patent No. 199,200 were granted to me January 15, 1878, so as to make it more convenient in use, more effective in operation, and better adapted for different kinds of planting.

A A are the drive-wheels, one of which rests loosely upon, and the other is rigidly attached to, the axle B. The axle B revolves in bearings attached to the longitudinal bars of the frame C. The two side bars at each side of the frame C, between which the drive-wheels A are placed, are adjustably secured to the front and rear bars of the said frame by bolts passing through slots in the said front and rear bars and screwing into the ends of the said longitudinal bars, to enable the drive-wheels to be adjusted farther apart or closer together, as the required distance between the hills may render necessary. To the axle B is attached a beveled gear-wheel, D, which is made in the form of three or more eccentric beveled gear-wheels, as shown in Figs. 6 and

8, to enable the motion of the feed to be regulated as required. Into the teeth of one or the other of the gear-wheels D mesh the teeth of a small beveled gear-wheel, E, attached adjustably to the rear end of the longitudinal shaft F. The shaft F revolves in bearings attached to a longitudinal bar of the frame C, and to its forward end is attached a small beveled gear-wheel, G, the teeth of which mesh into the teeth of a beveled gear-wheel, H, attached to the cross-shaft I. The shaft I revolves in bearings attached to the longitudinal bars of the frame C, and passes through the upper part of the conductor-spout J beneath the seed-hoppers K. To the shaft I, at the side of the seed-hoppers K, are attached beveled gear-wheels L, the teeth of which mesh into the teeth of the segmental gear-wheel formed upon and attached to the dropping-plate. To the frame C, directly over the conductor-spouts J, are attached plates M, having holes formed through them, through which the seed passes into said conductor-spouts J as it is removed from the hoppers K by the dropping-plate.

The dropping-plate is constructed and operated in the same manner as described in the Patent No. 199,200.

Upon the forward part of the lower end of the conductor-spout J is formed a recess to receive the shoe N, which is secured to the said conductor-spout by a bolt. Upon the forward side of the shoe N is formed an arm, O, which is curved upward and forward, and in the forward end of which is formed a hook-slot to receive the rod or rods P, the other ends of which are attached to the front cross-bar of the frame C or to the draft-clevis.

By this construction the arm O enables the machine to rise and pass over obstructions, and the detachable shoe N may be readily removed and replaced when worn or broken.

Q is a bent lever, which is pivoted at its angle to the platform of the frame C, in such a position that it may be readily reached and operated by the driver with his foot. The other end of the lever Q is forked to receive and ride upon the shaft I, where it rests against a collar, R, secured adjustably to said shaft by a set-screw or other suitable means. By this arrangement the driver, by operating the lever

Q with his foot, can readily throw the gear-wheels L out of gear with the dropping-plate, to enable the said dropping-plate to be turned back after being operated to drop the seed. The shaft I is moved in the opposite direction to throw the gear-wheel L again into gear with the dropping-plate by a spring, S, one end of which is attached to the longitudinal bar of the frame C, and its other end is forked to receive and ride upon the shaft I, where it rests against a collar, T, secured to said shaft adjustably by a set-screw or other suitable means.

U is the tongue, to which the double-tree V and the whiffletrees W are connected in the ordinary way. To the rear part of the tongue U is attached a cross-bar, X, which is connected and hinged to the front cross-bar of the frame C by eyebolts or clips, and which is strengthened by the braces Y, the forward ends of which are attached to the tongue U. The rear end of the tongue U projects to the rearward beneath the frame C, and to its rear end is attached a horizontal arm, Z, to the outer end of which is pivoted the lower end of a connecting-rod, A'. The upper end of the connecting-rod A' is pivoted to the lever B', the forward end of which is pivoted to a support attached to the platform of the frame C, and the rear end of which projects back into such a position that it may be conveniently reached and operated by the driver from his seat. The lever B' is slotted to receive the curved bar C', which has notches formed in its convex edge to receive a pawl, D', which slides in a guide attached to the lower side of the lever B'. To the rear end of the lever B' is pivoted a connecting-rod, E', which passes back beneath the said lever B', and is pivoted to a small bent lever, F', pivoted to the rear part of the said lever B'. By this arrangement, by operating the lever B' the forward part of the frame C and its attachments may be raised away from the ground, or lowered to plant the seed at any desired depth in the ground.

G' is the driver's seat, which is attached to the upper end of a spring-standard, H'. The lower end of the spring-standard H' is bolted adjustably to the rear cross-bar of the frame C.

As thus described, the machine is a two-horse planter, planting two rows at a time; but the same construction may be used for planting

one row at a time, as shown in Figs. 8, 9, 10, and 11. In this case the connecting-rod I' is pivoted to the end of the lever Q, which rod extends back to the rear of the frame C, and is pivoted to the upper part of a lever, J'. The lower end of the lever J' is pivoted to the rear part of the frame C, in such a position that it may be readily reached and operated by the plowman walking in the rear of the machine. In this case, also, the gear-wheel L slides upon its shaft when thrown out of gear by the lever Q. To the rear part of the frame C are attached plates K', in such position as to scrape off any soil that may adhere to the faces of the drive-wheels A, and thus keep them clean. L' is a marking-plow, which is made somewhat in the shape of two double-shovel plows placed base to base. To the two points of the plow-plate L' are attached arms M', which meet at an angle, as shown in Fig. 2. Through the angle of the arms M' and the center of the marking-plow plate L' passes the end of a brace-rod, N', which also passes through the end of a bar, O'. To the brace-rod N' and the bar O', near their inner ends, are attached the ends of the base-bar P', by which they are held in their proper relative positions. In the inner ends of the bar O' and the brace-bar N' are formed eyes to receive hooks Q', attached to the side bars of the frame C. The bar O' is made in two parts, the adjacent ends of which overlap and are secured to each other adjustably by bolts, so that the marker can be adjusted according to the required distance apart of the rows. By this arrangement the marker can be attached to either side of the frame C, according to the direction in which the planter is moving, and may be used whether the machine is adjusted as a two-row planter or a one-row planter.

Having thus fully described my invention, I claim as new and desire to secure by Letters Patent—

The shoe N, having arm O, curved upward and provided with hook-slot to receive rod P, as shown and described.

GEORGE WASHINGTON GRIMES.

Witnesses:

PETER STUDEBAKER,  
HUGH DOUGHERTY.