

G. A. NEAL.
Automatic Car-Brake.
No. 204,679. Patented June 11, 1878.

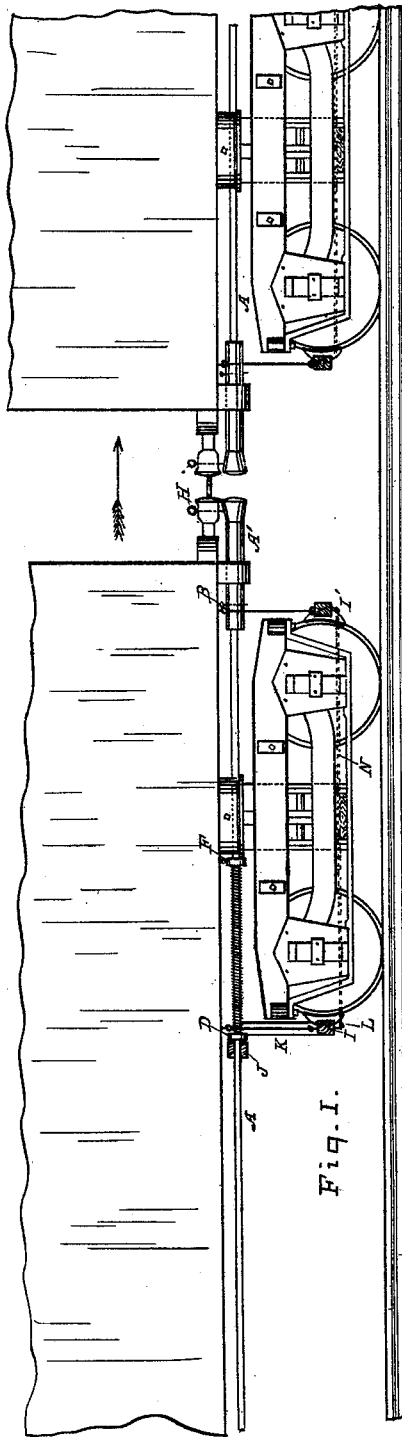

Fig. 1.

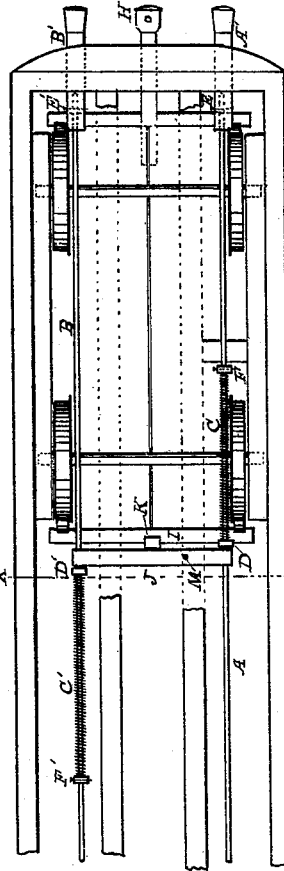

Fig. 2.

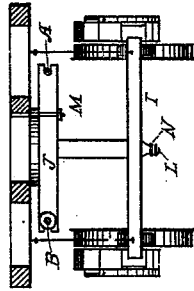

Fig. 3.

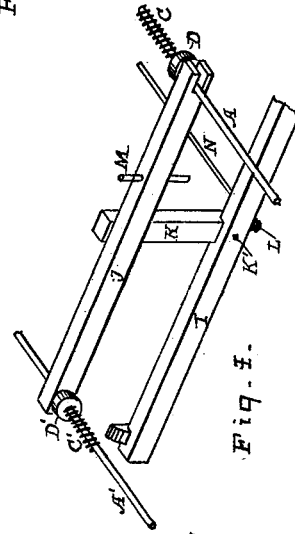

Fig. 4.

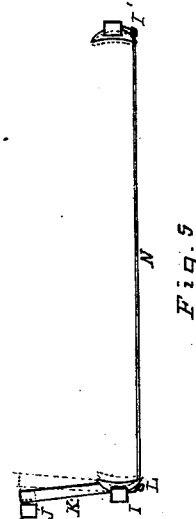

Fig. 5.

Witnesses:
John A. Duches
O. J. Bailey

Inventor:
George A. Neal,
By P. S. Perbe
Atty.

G. A. NEAL.
Automatic Car-Brake.

No. 204,679.

Patented June 11, 1878.

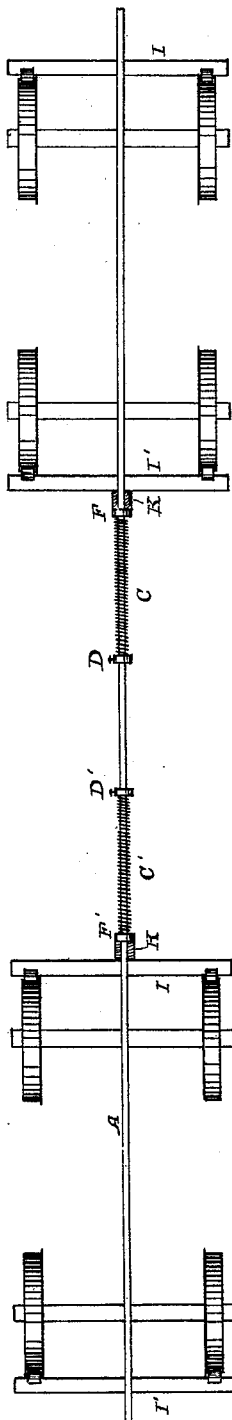

Fig. 6.

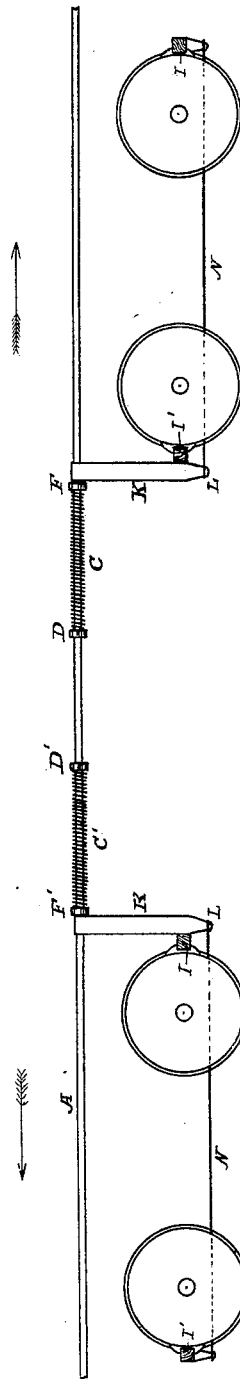

Fig. 7.

Witnesses:
John A. Hughes
O. J. Bailey

Inventor:
George A. Neal
By *J. S. Ferber*
Atty

UNITED STATES PATENT OFFICE.

GEORGE A. NEAL, OF SMITHFIELD, KENTUCKY.

IMPROVEMENT IN AUTOMATIC CAR-BRAKES.

Specification forming part of Letters Patent No. **204,679**, dated June 11, 1878; application filed April 22, 1878.

To all whom it may concern:

Be it known that I, GEORGE A. NEAL, of Smithfield, in the county of Henry and State of Kentucky, have invented a new and useful Improvement in Automatic Car-Brakes, which improvement is fully set forth in the following specification and accompanying drawing, in which—

Figure 1 represents a side view of cars equipped with my brake. Fig. 2 is a plan view. Fig. 3 is a cross-sectional view of Fig. 2 through the line *x*. Fig. 4 is a perspective view of lever attachment to brake, and Fig. 5 is a diagram showing the operation of the lever. Fig. 6 shows top view of modification, and Fig. 7 a side view of modification.

This invention has for its object the construction of an automatic car-brake so arranged that one man can regulate or check the speed of an entire train of cars, and by means of which the operation of braking or checking the cars will be regulated by the momentum of the train, the said device being cheap in construction and simple in all its details.

The invention consists in having each car provided with two adjustable rods, which are placed beneath and close to the under side of the car-floor, one on each side of the coupler, which rods are provided with ordinary buffers. These rods are also provided with springs and thimbles, which operate against compound levers for action against the brakes, as will hereinafter be more fully described.

By reference to the drawing, A B represent rods of suitable strength, which are provided with buffers A' B', which pass over the ends of the rods A B, and are fastened by pins E E', the rods A B being provided with a series of holes for adjusting the length of the said rods. The rods A B are placed on each side of the coupling-bar and slightly below it, so that they will clear the lower surface of the car. I provide these rods with spiral springs C C' and thimbles F F', having pins for adjusting the said thimbles whenever it is desired to compress the springs. On the rods at the opposite ends of these springs are movable thimbles D D', which operate against the ends of a horizontal cross-bar or lever, J. This lever is pivoted by a bolt, M, to the sill of the car at a point about one-fourth of its

length from one of the ends. This lever J, midway between its ends, engages the upper end of a vertical lever, K, which is rigidly bolted to the brake-piece I by means of a bolt, K'. The lever K extends below the brake-piece I, and is connected with the brake-piece I' by means of a rod, N.

In the practical operation of my brake it is designed to have the tender of the engine supplied with steam-cylinders and piston-rods, the positions of which shall correspond with the rods A B. These rods A B are adjusted so that they shall not extend beyond the coupling-bar H. When steam is applied to the cylinders the piston-rods (which are also provided with buffers similar to A' B') force the buffers beyond the coupling-bar. This movement causes a corresponding pressure to be exerted on the rod in the car next to the tender, and extending the opposite end of the rods A B beyond the coupling-bar.

As represented in the drawing, the cars are supposed to be moving toward the right of the sheet. The rod A being moved toward the left by the action of the piston, the thimble D operates against the horizontal lever J, throwing forward the upper end of lever K. The brake-blocks on I I' being held together by the rod N, the said movement causes the blocks to bind against the wheels; and since the rods A B are provided with springs C C', the pressure against the wheels cannot be so great as to create any unnecessary strain or tension. The car next to the rear, being similarly equipped, will operate likewise, and automatically lock its own wheels.

The operation of braking is more fully shown by Fig. 5, the dotted lines representing the position of the lever K and brake-blocks I I' when operated on by the rod A and thimble D.

I provide each car with two rods, the rod on one side being designed for use when the engine is at one end of the car, and the other rod when the engine is at the other end, so that the brake can be applied whether the car moves backward or forward. The rods can be manufactured with a series of holes, by which the thimble F can be adjusted by means of a pin.

In Figs. 6 and 7, I represent a modified form

of applying my invention, by which I employ only one rod. This rod is placed in the center of the car, directly below the coupling-bar, but not near enough to interfere, and is also equipped with buffers similar to those shown in Fig. 2. Instead of having one spring on each rod, I employ two springs, C C', Figs. 6 and 7, and also full brake equipment on each truck, so that should the car be moving in one direction the forward brakes will always operate.

I am aware that rods similar to mine have been employed for braking purposes, and I do not claim the rod, broadly; but I am not aware that movable collars have been employed on rods for this purpose.

Letters Patent No. 112,456, dated March 7, 1871, describe collars for operating brake-levers; but those are permanently affixed to the rod, and it is evident that when the brakes are applied the rods can only be forced a given distance, and should the rear cars fail to close the space the brakes on the front cars alone will be affected. Consequently the front cars will have to bear all the power applied, whereas the springs and movable collars I employ readily meet this objection by forcing down the brakes on the cars to which they are attached, and then continue to approach the rod of the following car without increasing the

strain on its own brakes. The springs I employ are designed to apply the brakes, while the springs in the Letters Patent referred to are intended to withdraw them from the wheels. The said Letters Patent describe rods of uniform length without means of adjustment, and have no provision for long or short couplings; and, since the rods can move only through a given space, it is necessary for them to join as soon as the slack is taken up, which prevents the cars from backing. This serious objection is entirely obviated by the use of the adjustable rods and movable thimbles herein described. Now,

What I claim as new, and desire to secure by Letters Patent, is—

In a car-brake, an adjustable rod, A, provided with spring C and movable thimbles D F, in combination with horizontal lever J, pivoted substantially as shown, vertical lever K, rigidly attached to brake-piece I, and operating as described, and for the purpose set forth.

In testimony that I claim the foregoing I have hereunto set my hand this 7th day of March, 1878, in the presence of witnesses.

GEORGE A. NEAL.

Witnesses:

W. H. MEAD,

D. G. MEAD.