

W. BEUKLER.
Plaiting-Machine.

No. 204,704.

Patented June 11, 1878.

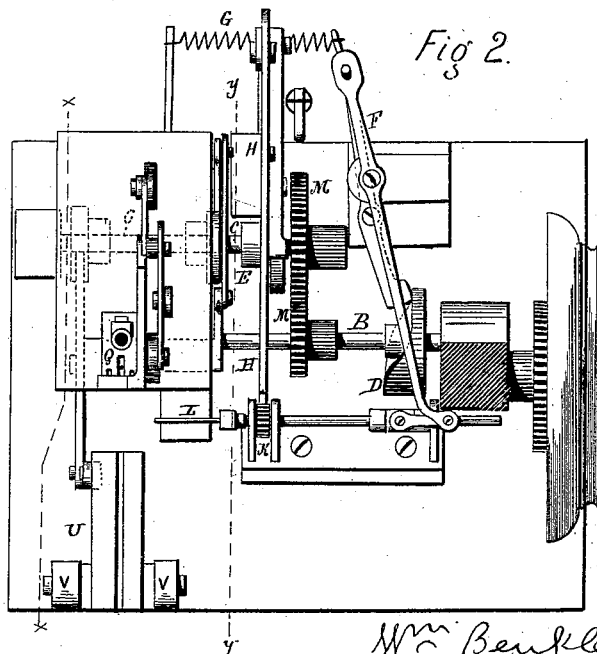
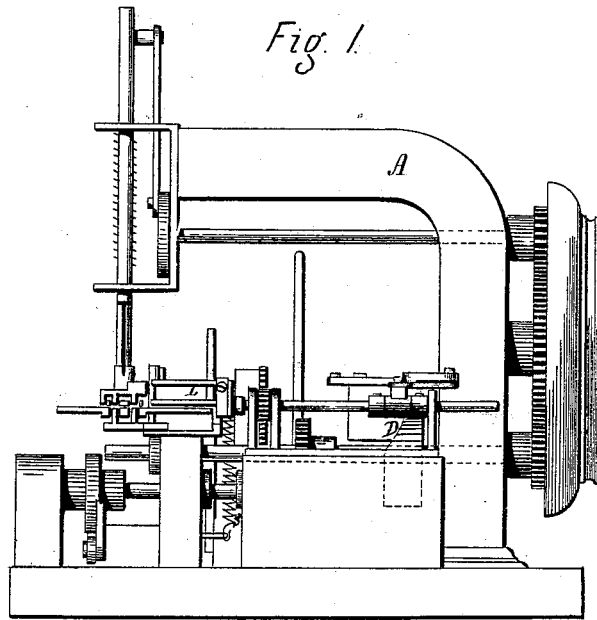

Witnesses:
John W. Ripley
Henry J. Hoop.

Wm Beukler Inventor
by L. J. Gordon Atty

W. BEUKLER.
Plaiting-Machine.

No. 204,704.

Patented June 11, 1878.

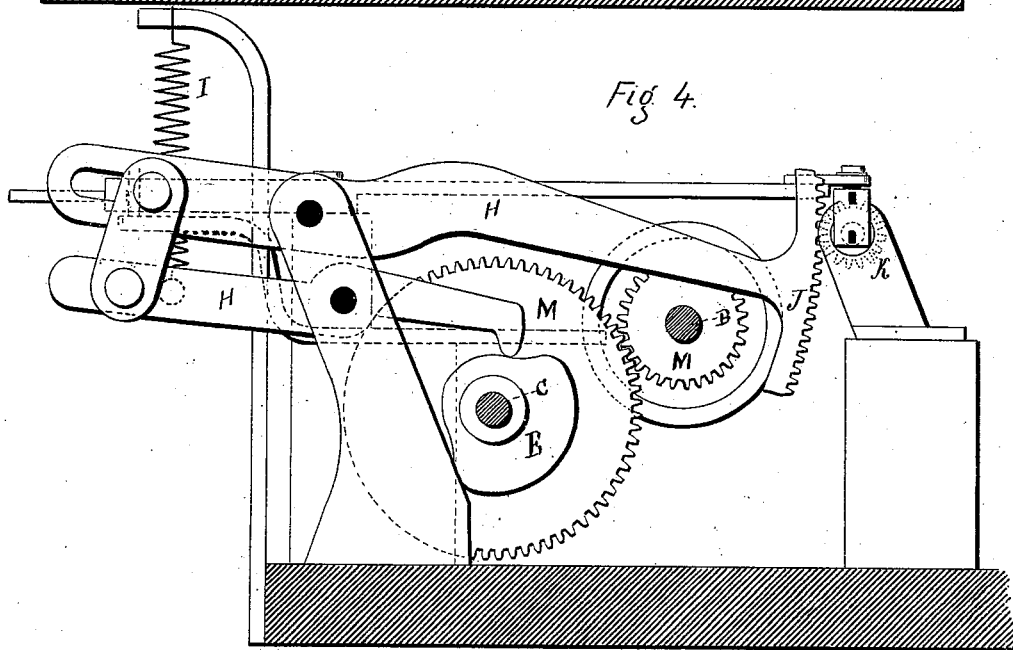
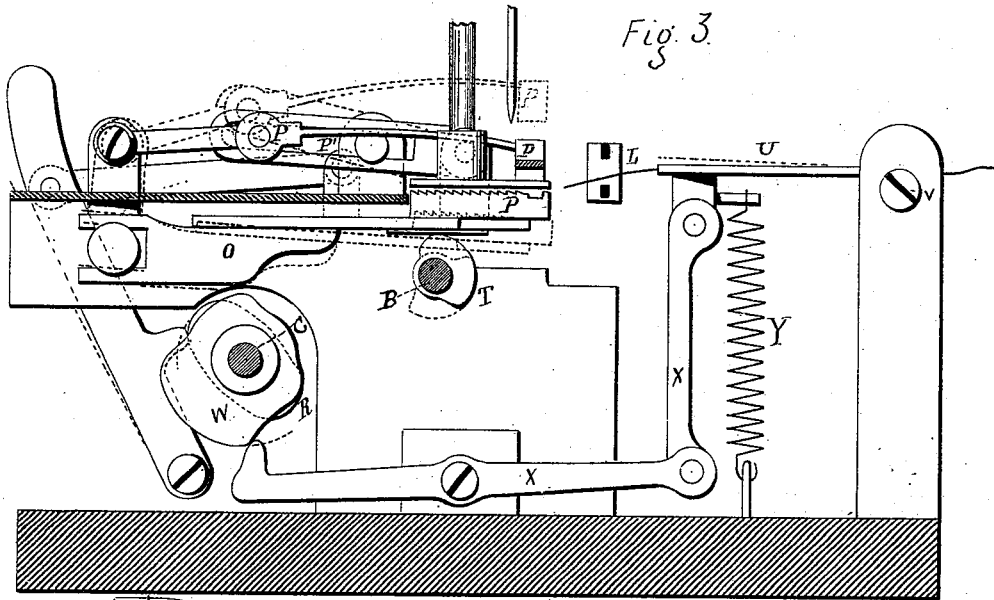

Witnesses
John W. Rapsley
Henry C. Hoyle

Wm Beukler
Inventor
by L. J. Gordon Atty.

W. BEUKLER.
Plaiting-Machine.

No. 204,704.

Patented June 11, 1878.

Fig. 5.

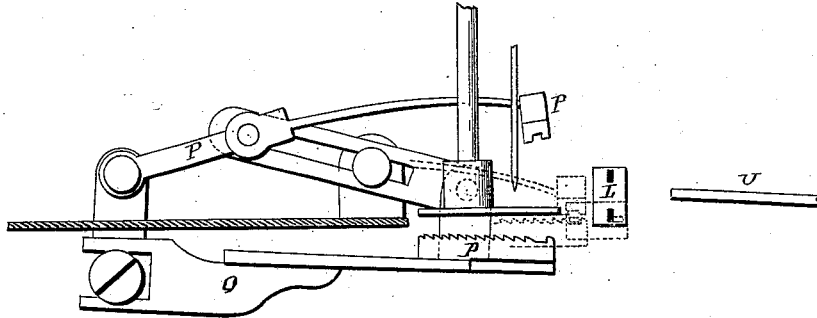
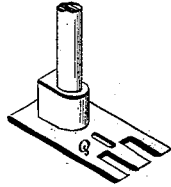

Fig. 6.



Witnesses.
John W. Ripley
Henry J. Hoyt.

Wm. Beukler
Inventor
by S. J. Gordon Atty

UNITED STATES PATENT OFFICE.

WILLIAM BEUKLER, OF NEW HAVEN, CONNECTICUT.

IMPROVEMENT IN PLAITING-MACHINES.

Specification forming part of Letters Patent No. **204,704**, dated June 11, 1878; application filed October 8, 1877.

To all whom it may concern:

Be it known that I, WILLIAM BEUKLER, of New Haven, county of New Haven, State of Connecticut, have invented a new and useful Improved Plaiting-Machine, which is fully set forth in the following specification and accompanying drawings, in which—

Figure 1 is a side view of my improved plaiting-machine; Fig. 2, a top view thereof; Fig. 3, a section on line *xx* of Fig. 2; Fig. 4, a section on line *yy* of Fig. 2; Fig. 5, a detached view, and Fig. 6 a detached view.

The object of my invention is to produce a plaiting-machine of positive action, which shall form more accurate plaits with greater certainty and rapidity than any previous machine of the kind, and particularly one capable of plaiting "crepe lisse" goods, which has never before been successfully accomplished.

A represents the frame of the machine; B, the main shaft; C, the auxiliary shaft; D, the plaiter-driving cam; E, the plaiter-reciprocating cam; F, the plaiter-driving lever; G, the return-spring thereof; H, the plaiter-reciprocating lever; I, the return-spring thereof; J, the segment-revolving gear; K, the plaiter-reciprocating gear; L, the forked plaiter; M M, shaft-connecting gear-wheels; O, the feed-bar; P, the auxiliary feed; Q, the slotted presser-foot; R, the feed-cam; S, a spring for holding feed-operating lever against the cam; T, the feed-lifting cam; U, a guide for the material hung on centers V V; W, the guide-lifting cam; X, the guide-connecting lever; Y, the return-spring thereof.

The action of the machine is as follows: Lace or other material being led through guide U and under presser-foot Q, revolving shaft B and cam D, through lever F, cause plaiter L to advance, one prong thereof passing above and the other below the material. Cam E, by means of lever H and gears J and K, reciprocates plaiter L, the stationary prong above the material simply turning on its axis and allowing the material to fold over it, while the other prong takes up a width of material, and, turning it completely over, thereby forming at the outset a complete and perfect plait,

brings it between the advancing jaws of the compound feed-bars O and P, which close upon it and carry it forward under presser-foot Q, spring G having, however, drawn plaiter L back before the feed-jaws started. The next time the lower prong is reciprocated by cam E it turns the material under instead of over the other prong, and so a box-plait is laid, cam W, lever X, and spring Y raising and depressing guide U, so as to bring the material first above and then below the prong over which the plait is first fed.

The auxiliary feed conforms to the slots of the presser-foot, and both jaws of the compound feed take hold of the plait before it reaches the presser-foot, thus forming the plait completely before the sewing-machine proper acts upon it.

What I claim as my invention, and desire to secure by Letters Patent, is—

1. In combination with a forked plaiter, mounted in suitable bearings, mechanism, substantially as described, for imparting to the said plaiter a rotary reciprocating motion, essentially as set forth.

2. In combination with forked plaiter and mechanism for imparting to the same a rotary reciprocating motion, mechanism, substantially as described, for reciprocating the said plaiter in the direction of its length, as set forth.

3. The combination of the rotary reciprocating plaiter and the compound feed, constructed to operate together, substantially as and for the purposes herein described.

4. The combination of the rotary reciprocating plaiter, the compound feed, and the presser-foot, constructed to operate together, substantially as and for the purposes herein described.

5. The combination of the rotary reciprocating plaiter, the compound feed, and the feed-guide, all constructed and operating together, substantially as and for the purpose described.

WM. BEUKLER.

Witnesses:

JOHN W. RIPLEY,
S. J. GORDON.