

A. DELKESCAMP & F. B. BRADLEY.

Machine for Making Eyelets.

No. 204,716.

Patented June 11, 1878.

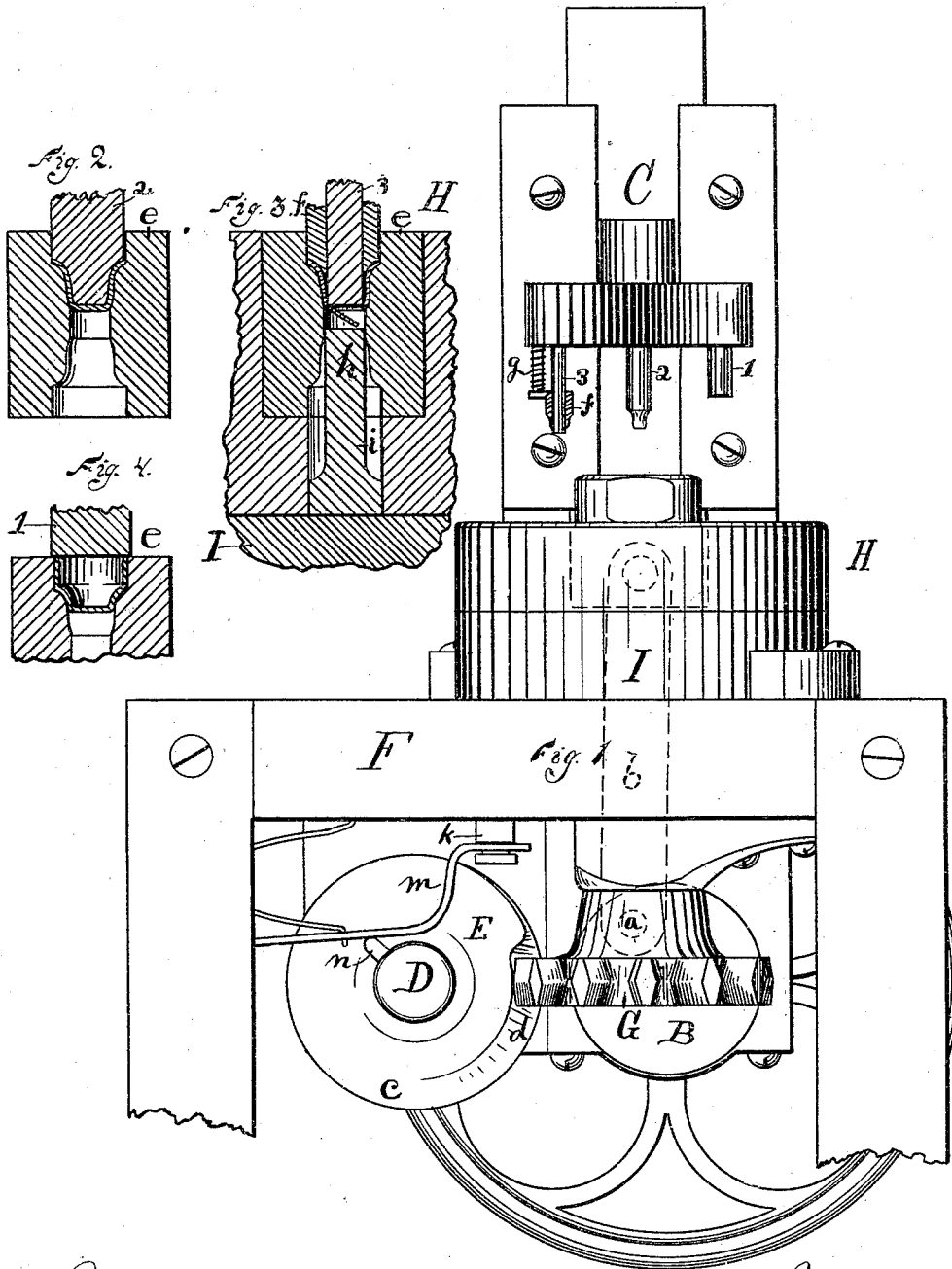

Witnesses.
 H. N. Gale,
 W. B. Thomson.

Inventors.
 Adolph Delkescamp
 Franklin B. Bradley
 By James Shepard Atty.

A. DELKESCAMP & F. B. BRADLEY.

Machine for Making Eyelets.

No. 204,716.

Patented June 11, 1878.

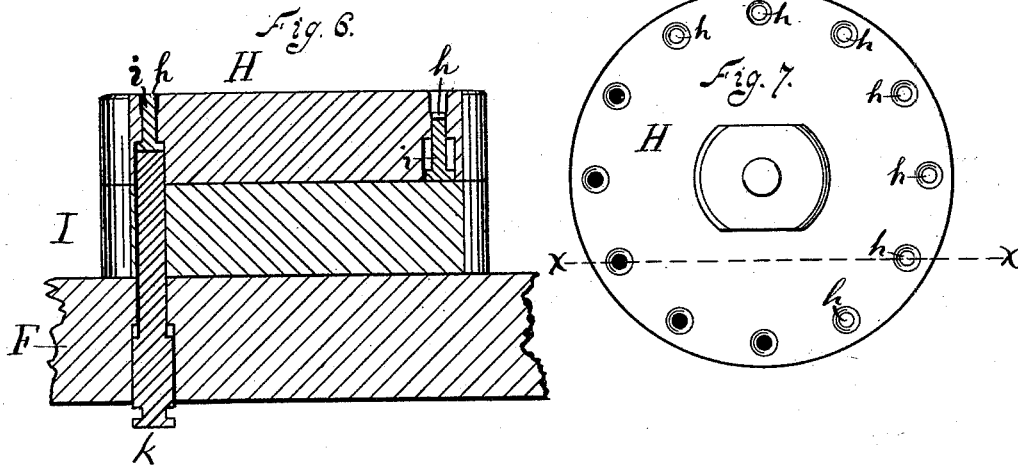
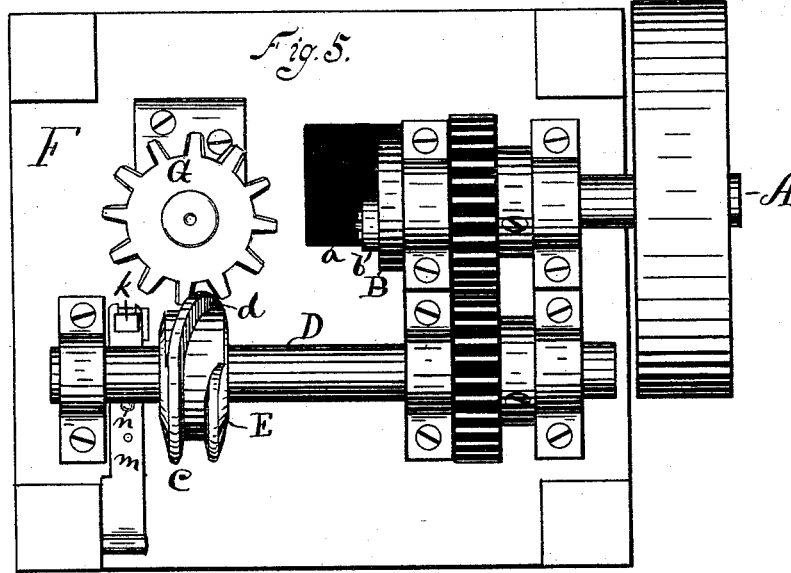

Fig. 8.



Witnesses
 H. J. Gale,
 W. B. Thomson.

Inventor
 Adolph Delkescamp
 Franklin B Bradley
 By James Shepard Atty.

UNITED STATES PATENT OFFICE

ADOLPH DELKESCAMP AND FRANKLIN B. BRADLEY, OF SOUTHWINGTON, CONNECTICUT; SAID DELKESCAMP ASSIGNOR TO SAID BRADLEY.

IMPROVEMENT IN MACHINES FOR MAKING EYELETS.

Specification forming part of Letters Patent No. 204,716, dated June 11, 1878; application filed October 4, 1877.

To all whom it may concern:

Be it known that we, ADOLPH DELKESCAMP and FRANKLIN B. BRADLEY, both of Southwington, in the county of Hartford and State of Connecticut, have invented certain new and useful Improvements in Machines for Making Eyelets, of which the following is a specification:

Our machine is designed for the manufacture of eyelets from cup-shaped blanks previously formed in any suitable machine; and the invention consists of the peculiar construction and operation of devices, in the combination of parts for and in the manner of swaging said blanks into proper form, removing the end therefrom, and then throwing the finished eyelet out of the machine, as hereinafter described.

In the accompanying drawings, Figure 1 is a front elevation of a machine for making eyelets which embodies our invention. Figs. 2, 3, and 4 are enlarged sectional views of detached parts, showing three different operations, hereinafter explained. Fig. 5 is an under-side view of said machine. Fig. 6 is a vertical section of detached parts on line *xx* of Fig. 7. Fig. 7 is a plan view of the die-table of said machine, and Fig. 8 is a sectional view of a blank from which the eyelets are made with our machine.

Motion may be imparted to the main shaft A, Fig. 5, in any proper manner. On one end of said shaft is a disk, B, carrying crank-pin *a* and pitman *b*, connected to the vertically-reciprocating carriage C, Fig. 1, which carries the several punches, said pitman being indicated by broken lines in Fig. 1. Parallel to the main shaft A is a counter-shaft, D, the two shafts being connected by suitable gear, so as to revolve together. Upon the shaft D is a flanged hub, E, provided with a single peripheral flange, *c*, which extends about one and three-quarters time around the hub, the two ends lapping by each other for about three-quarters of the way around said hub. The portion of this flange where there is no lap is spiral or inclined, as at *d*, which inclined portion *d* crosses the edge of the hub, while the other portions of said flange are straight and parallel to each other and the sides of the hub.

Upon the under side of the bed F there is a spur-wheel, G, having twelve teeth, with which the flange *c* of the hub E engages. As the hub revolves, the inclined portion *d* of the flange *c* moves the wheel G one tooth, which movement takes place during a quarter-revolution of the shaft D. When the incline passes the teeth of wheel G, the straight portion of the flange *c* is engaged therewith, and holds the wheel perfectly motionless for three-quarters of a revolution of the shaft D, when the incline again moves the wheel G one tooth or one-twelfth of a revolution, when the straight portion again holds it motionless, whereby it will be seen that the wheel G revolves with an intermittent motion. By means of a short vertical shaft through the bed F, the wheel G is connected to the die-table H, whereby said die-table also revolves with an intermittent motion.

The crank-pin for imparting motion to the carriage C is so placed relatively to the incline *d* of flange *c* that the movement of the die-table takes place when the carriage C and its punches are in, or nearly in, their most elevated position. The die-table is provided with as many dies as there are teeth in the spur-wheel G, which dies may be formed directly in said table, or in separate blocks or removable dies *e*, Figs. 2, 3, and 4, let into sockets in the die-table H, as shown in Fig. 3, in which case there may be a die at each end of the blocks. The dies in these blocks or table are all of them formed alike, and the counter part of the sides of a finished eyelet but sunk straight in a little below the top surface of the die-blocks, as shown in Figs. 2, 3, and 4.

The cup-shaped blanks represented by the enlarged sectional view, Fig. 8, are placed in the dies of the die-table by hand, or by means of any suitable automatic feeding mechanism, as may be desired. When a die with a cup-shaped blank, Fig. 8, placed in it comes under the punch 1, the table is held stationary by means of the straight portion of the flange *c*, as before described, and the carriage C descends, thereby bringing the square end of the short punch 1 against the end of the blank and forcing it into the die with its top edge even with the top face of the die. If desired, the

punch may be made of about the same diameter as the straight portion of the die, so that said punch may enter it a short distance without injury to the machine, in order to avoid the fine adjustment necessary to stop the punch at an exact point. All of the punches may be made adjustable and held in place by proper set-screws, which it is not necessary to show.

The action of the punch 1 is to plant the blank firmly and squarely in the die for subsequent operation, and, in doing so, the lower rounding corners are swaged inward slightly, as represented in Fig. 4. Because the punch 1 bears only upon the end of the blank and is not forced down into the die, the blank may rock on its solid and rounded end after the punch strikes it, so that it may right itself up within the die and be squarely seated therein. After thus seating the blank the carriage C and its punches rise, leaving the partially-swaged blank firmly placed in the die, when the mechanism before described rotates the die-table one-twelfth of a revolution and brings the said blank under the punch 2, the form of which is the counterpart of the inside of a finished eyelet, which punch is forced into the die and swages the blank into its final form, except that its solid end has not been removed, as shown in Fig. 2.

The next reciprocation of the carriage C withdraws the punch 2, the blank still remaining in the die, when the next intermittent movement of the die-table brings the die under the compound punch 3 *f*. This punch consists of the punch proper 3, which is of the size and shape designed for the hole in the small end of the eyelet, and of the spring-follower *f*, fitted to slide up and down on the punch proper, and continually pressed downward by a spring, *g*, Fig. 1, coiled either directly around the punch or around a parallel sliding shaft at its sides, as shown in said figure.

When the follower is depressed the general shape of the compound punch 3 *f* is substantially the same as that of punch 2, and it fits the inside of the blank.

When it descends into the die and blank, the whole punch is first firmly planted within said blank, the spring *g* pressing the follower downward with all its power; but as the follower cannot go any farther the further movement of the carriage C carries the punch downward to punch out a round disk or slug from its solid end, while the spring yields and allows the follower to remain stationary as the punch descends, which follower firmly and squarely holds the blank immovable within the die while the solid end is being punched out.

Within the die *e* and below the small end of the blank, at a distance from said blank less than the diameter of the disk punched out, is the table end *h* of the knock-out *i*. The lower end of this knock-out rests upon the upper surface of the elevated bed I, whereby it is

supported in position under the punch 3 *f*, as shown in Fig. 3.

When the disk or slug is punched out it often hangs on one side of the die; and if the metal is very thin or the punch a little dull, the slug has a tendency to turn as on a hinge and let the punch slip by it without completely severing the disk from the end of the eyelet-blank. The table end *h* of the knock-out *i* is placed and held in the position shown to avoid such a result.

Whenever the metal hangs at one edge and the disk or slug turns down into the position shown in Fig. 3, it is stopped from turning down farther by contact with said table end, which holds it at an angle to the path of the punch 3, so that the further movement of said punch completely severs the disk or slug from the eyelet. Although this table end is held a distance from the die less than the diameter of the slug, still it is so far below the lower end of the eyelet as to allow the punch 3 to pass completely through the same without contact with this table end.

The die-table H is mounted on the elevated bed I, which might, if desired, be a part of the bed F. Through the beds F I is a plunger, *k*, the lower end of which is connected to the end of a spring, *m*, so as to move both ways therewith.

Upon the shaft D is a cam or pin, *n*, which, at every revolution of the shaft D, lifts the spring *m* and throws the plunger *k* upward, said action taking place when the die is stopped directly over the end of the plunger.

All of the several dies are provided with the knock-out *i*.

The plunger is so located that the die last operated upon will come over the plunger at the second twelfth of a revolution after leaving punch 3. The plunger *k*, in moving upward, comes in contact with the lower end of the knock-out *i*, and carries it into the position shown in Fig. 6, when the eyelet is necessarily thrown out of the die. The cam or pin *n* then recedes from the spring *m*, which springs downward and draws the plunger down with its upper end about even with the upper surface of the elevated bed I.

If desired, the lower end of the knock-out might be made larger than the upper end of the plunger and the hole in which it works, so that in case the plunger is lowered below the upper surface of the bed I, the knock-out will not fall down below the upper surface of said bed. At the next twelfth revolution of the die-table the die and knock-out will be carried along with the die over a solid portion of the bed I, as shown in Figs. 3 and 6. In case the knock-outs *i* do not fall down upon the bed I of their own weight, they will be forced down by refilling the dies with new blanks before they come under the punch 1.

We have herein followed only one blank on its course through the machine; but if the dies are properly supplied all of the several operations will take place simultaneously, and when

the machine is once under way an eyelet is formed at every reciprocation of the carriage C.

We claim as our invention—

1. In a machine for making eyelets, the punch 2 and intermittingly-moving series of dies in which the eyelet-blanks are swaged, in combination with bottom-removing punch 3, having spring-follower *f*, shaped to fit the interior of the blank as swaged by dies and punch 2, whereby the bottoms of the eyelets are removed without removing them from the die in which they are swaged, substantially as described, and for the purpose set forth.

2. That improvement in the art of making eyelets from previously-prepared cup-shaped blanks, which consists, first, of partially swaging said blank and leaving a portion unswaged, producing thereby the form shown in Fig. 4; second, striking the result of the first operation by another punch to force it farther into the same die and complete its form; and, third,

striking the result of the second operation by means of another punch, which removes its solid end, all of said punches operating upon the blank while in the same die and without removing it therefrom, substantially as described, and for the purpose specified.

3. In combination with the intermittingly-revolving die-table H and its bed I, a die and punch for removing the end of an eyelet-blank, the knock-out *i*, and its table end *h* firmly supported at a distance from the end of the blank less than the diameter of the piece to be removed, and with a space between said table end and the end of the blank, substantially as described, and for the purpose specified.

ADOLPH DELKESCAMP.
FRANKLIN B. BRADLEY.

Witnesses:

C. M. DEARTH,
T. B. SMITH.