

T. B. GUNNING.
Ejector for Oil-Wells.

No. 204,725.

Patented June 11, 1878.

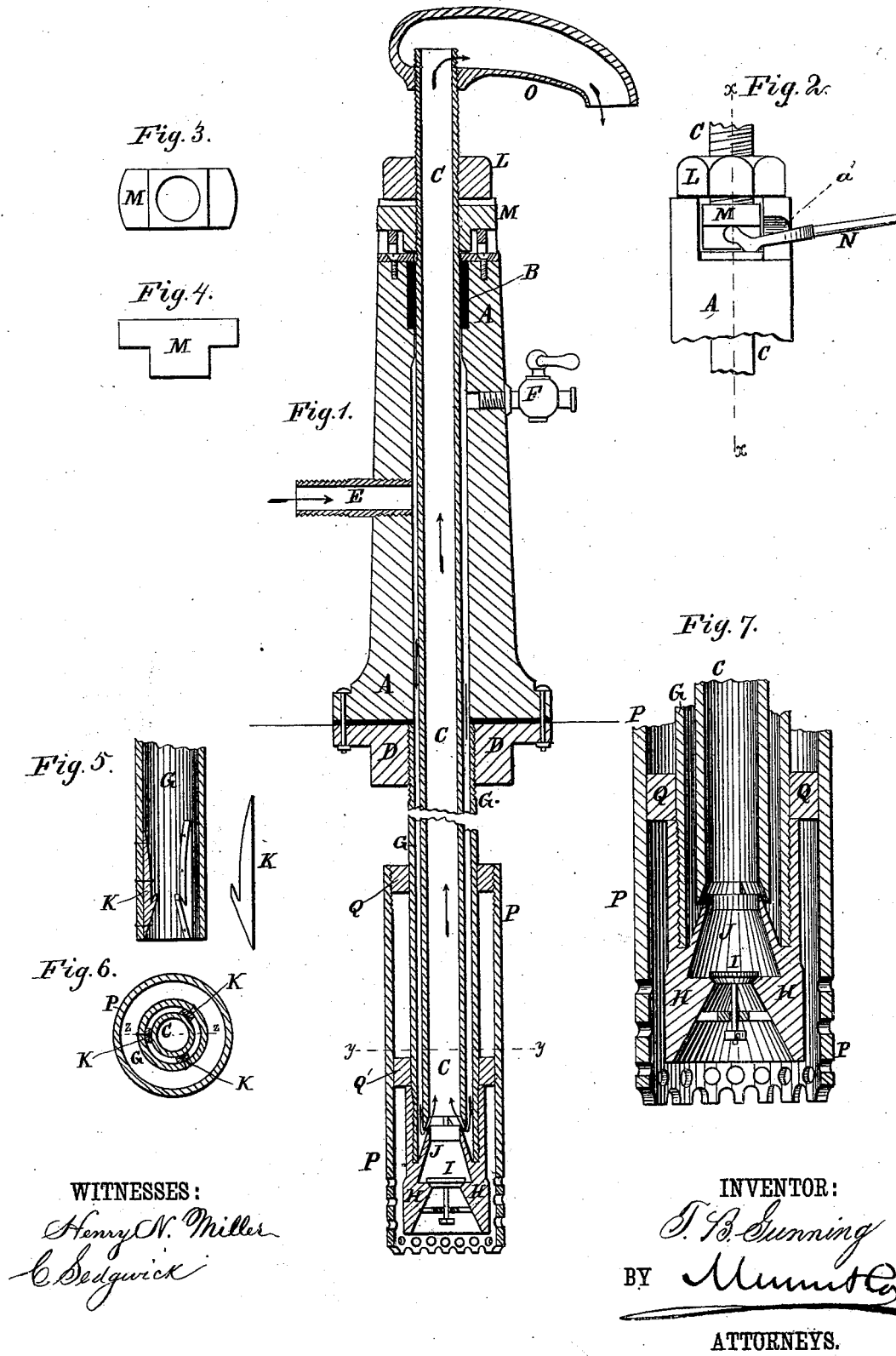

WITNESSES:
Henry N. Miller
C. Sedgwick

INVENTOR:
T. B. Gunning
BY *Mumford*
ATTORNEYS.

UNITED STATES PATENT OFFICE

THOMAS B. GUNNING, OF NEW YORK, N. Y.

IMPROVEMENT IN EJECTORS FOR OIL-WELLS.

Specification forming part of Letters Patent No. 204,725, dated June 11, 1878; application filed April 1, 1878.

To all whom it may concern:

Be it known that I, THOMAS B. GUNNING, of the city, county, and State of New York have invented a new and Improved Ejector for Oil and other Wells, of which the following is a specification:

Figure 1 is a vertical longitudinal section of my improved apparatus, taken through the line *x x*, Fig. 2. Fig. 2 is a side view of a part of the same. Figs. 3 and 4 are detail views of the cross-nut or screw-collar. Fig. 5 is a detail longitudinal section of the lower end of the pipe, showing the guides, taken through the line *z z*, Fig. 6. Fig. 6 is a horizontal section of the lower part of the same, taken through the line *y y*, Fig. 1. Fig. 7 is a detail longitudinal section of the lower part of the apparatus enlarged.

Similar letters of reference indicate the same parts.

This invention consists of two pipes, C and G, one within the other, so adjustable relatively by a lever, N, and connected with a nozzle, J, and a valve, I, at their lower ends, that the air forced down one pipe is turned by the nozzle J into and up the other, so that an upward current is produced, which sucks up from the bottom of the well and carries its fluid contents up through the ejection-pipe, the bore of which is clear of any obstruction to the rising fluid. The spout is so large as to carry the contents freely away, so that while the air is pumped in its pressure is continually applied to force up the contents of the ejector.

With the aid of the lever N the valve I shuts off from the well any weight of the fluid column, and it is forced out of the ejector without lifting a column equal to the whole depth of the well, or in proportion to the pressure of the air forced in, a certain weight of the rising column of fluid is shut off from the well by the closing of the valve, and by the time this fluid is forced out of the ejection-pipe the upward current from the well is restored, and this alternation goes on automatically.

The iron standard A is bolted down to a bed-plate, D, which lies upon a firm foundation on the earth, and supports a pipe, G, which extends down the bore of the Artesian well. The standard A is so placed as to form

a continuation of the pipe, G, which supports a collar, L, which screws onto and holds a smaller pipe, C, that passes down the inside of the larger one, so as to leave an annular space between these outer and inner pipes from the packing-box B in the standard A to the reflector J, which slants in above the valve-seat at the lower end of the external pipe G.

The nozzle J and the valve-seat may be cast in separate pieces and fastened together, the valve I being below the reflector-piece J, which is screwed onto the outer side of the pipe G. The nozzle J extends up from the rim of the lower end of the outer pipe G, slanting in at about fifteen degrees, and its end is on a line with the inner surface of the smaller pipe C, and one-eighth of an inch below its end, which is cut to somewhat less slant than the reflector J, so that an annular opening is left between the reflector J and the end of the inner pipe C.

To guide the inner pipe C into the center of the outer, and to hold it there, three strips of metal, K, are fastened to the inside of the larger pipe G, at equal distances apart, their lower inner surfaces resting against the nozzle J. These three strips K thus project in between the reflector J and the pipe C, and prevent the annular opening from being closed. For an inch above the annular opening they are of such thickness as to bear against the external surface of the inner pipe C; but above this they taper to a feather-edge, which is firm against the outer pipe G, so that the inner pipe C, with its sharp edge rounded off, will be guided into place.

The guides K should only be wide enough for the screws or rivets to hold them firm on the outer pipe G. In this way the bore of the small pipe C will be held in range with the reflector J, and with the opening to the valve I below.

For convenience of fitting these parts and to protect them, a coupling, Q, having a screw on its external circumference, is placed on the large pipe above its lower end, and a smooth collar, Q', just above the valve-casting H. Upon the coupling Q a piece of pipe, P, is screwed, its inner surface resting against the smooth collar Q', which is a little larger than

the outside of the valve-casting H. This pipe P is pierced with holes below the bearing, so that while the valve is protected it is still open to the contents of the well.

The inner pipe C, which is supported by the large collar L, which lies flat on the top of the standard A, has a screw cut on its upper end, and the supporting-collar L being screwed on so far that several inches of the pipe stand above it. The area of the bore of the inside pipe is about equal to that of the annular space between the two pipes. The pipe C extends nearly to the nozzle, which is supported with the valve I by the lower end of the outer pipe G. The annular opening has an area of about one-fourth that of the bore of the small pipe C, and in order to enlarge this passage a lifting-collar, M, is screwed onto the pipe C below that which holds it, and to admit this collar the top of the standard A is cut out across its center. The contracted portion of the bore allows the inner pipe to pass freely; but above this projecting rim the bore is turned smooth to hold the packing B, which rests on a flat ring of metal which fits exactly to the pipe, this last being also turned smooth where the packing touches it, the rim which supports the packing-ring being quite clear of the pipe, as before stated. The flat upper surface of the standard supports the holding-collar L, while a lower flat surface bears the lifting-collar M. This surface, back of its center, also affords a fulcrum for a forked lever, N, which rests on each side in a socket, the lever being kept from falling out by its points bearing up against the center of the projecting surfaces, which reach out so as to lift the pipe squarely. The lever-points are close against the flat sides of the lifting-collar, and the standard is notched to afford room for the lever to move the pipe up and down to vary the size of the annular opening above the reflector. The length of the lever and the distance between its points and the bearings which lie in the fulcrum-socket must be proportioned to the length of the pipe. The outer pipe hangs directly from the bed-plate D, upon which also the standard A rests, supporting the inner pipe C, which may inclose a column of oil, &c.

The side of the standard A has a circular opening, E, through which air is forced into the annular space, and the packing-box B prevents this air from passing up and out around the inner pipe C, and the lifting-collar M of this pipe falls on the packing-box B. This air, under the required pressure, when forced into the standard A by any suitable means, will pass down the annular space, and be turned by the reflector J through the narrow opening up the internal pipe C, the valve I below this current being open; but should anything interrupt this upward current the valve I will fall, and, while preventing downward pressure on the contents of the well, will make all the pressure of the air subservient in forcing the contents of the ejector up and out of the open end of the internal pipe C.

This will be clearly shown in the following directions for using this ejector in a petroleum-oil well.

The air-pipe G should be let down as near the bottom of the oil-vein as consistent with safety—that is, so as not to stand, but hang from the top of the well with its end nearly touching. In this way any oil which runs into the vein will be drawn in by the upward current established in the ejector, and the gas in the well will aid in forcing up the oil, whereas, in holding the valve even a few inches above the floor of the vein, gas might fill the ejector and leave the oil below. But by letting the pipe down close to the bottom of the well the oil, if present, will be sucked up before or with the gas, according to the amount of the oil. In such cases there will be a continuous suction upon the contents of the well, instead of the intermittent action of the pumps now in use, provided the ejection-pipe is let down so close to the reflector that the passage between is much less than the area of the ejection-pipe, the size of the passage being, say, one-fourth or much less than that of the bore of the ejection-pipe.

Different wells may require different proportions between the size of the passage and that of the ejection-pipe, and the proper size of the passage will be determined by moving the inner pipe C by means of the lever N.

Deeper wells will, of course, require greater pressure in the air forced down the air-pipe than wells of only five or six hundred feet in depth; but, however great the pressure or the volume of the air forced down, an upward current from the well can be attained only by the air from the reflector going through a passage smaller than the bore of the ejection-pipe, and causing a larger body of air to move up and draw out from the well below; but if the passage between the pipes is too near in size to the bore of the ejection-pipe, the reflected air will go through in such quantity that, not having room to pass up, it will turn down upon the contents of the well below until the valve closes; and here we see the only use of the valve, which is to prevent pressure down the well, whether from the air-passage between the pipes being too large or from the air-pressure being too feeble to force up the column of oil rapidly or otherwise.

In oil-wells the product varies so much from the presence of water and gas, and the effect of the latter is so uncertain, that it is not possible to say what pressure of air may be required even for a particular depth of the well. The air, when turned by the reflector J so as to draw up oil, &c., from the well, will pass upward, carrying the heavier fluid against the surface of the pipe C, which is open from top to bottom, excepting the valve I at the lower end of the pipe, which must be opened, and even this could perhaps be left off in some cases with advantage—say, when the yield of oil is light but steady in its flow, and the well not very deep—but in wells, say, from ten to

fifteen hundred feet deep, a steady upward current could hardly be maintained without the valve, as there would be an inconvenient and unprofitable amount of pressure in the air forced down, and in case of check to the upward current it is not possible that the air could force up the fluid-column to any great extent without resting on the contents of the well, for it would press down as much as up, and as the pressure in the oil-veins is not sufficient to send the oil up the ejection-pipe, it could hardly do so when air was forced down, and to enlarge the passage by means of the lever would only increase the backward pressure in the oil-vein. All difficulty is, however, remedied by the valve, which, in shutting at the moment the upward current is checked, keeps all the pressure of the air steadily employed in raising the fluid-column. The current from the well is at once stopped by lifting the pipe C with the lever N, or automatically, whenever the ascending column becomes so heavy that the pressure of the air cannot keep the valve open, so that with a valve the pressure of the air will determine the weight of the column of oil which is closed in from the well and carried up at one time in any depth of well.

It is, of course, seen that these directions refer to wells properly cased, so that water is shut out as much as possible. No reference has been made to any seed-bag or its equivalent attached to the ejector, although the protecting-pipe would afford a good surface for a simple envelope, which could even be expanded by the air-pressure through the supporting-

coupling; but if the condition of the well were found to indicate that the space between the outer pipe and the casing could be advantageously shut up, in addition to the cover at the mouth of the well, the operator would readily see it.

The holding-collar L, or a detent on the lever N, would keep the central pipe at any required height.

The vent-cock F in the standard may be left open during the spurting of the well.

Having thus fully described my invention, I claim as new and desire to secure by Letters Patent—

1. The standard, A with a packing-box, B, and with fulcrum-sockets for the lever N, which standard A also affords support at its uppermost end to the collar L, and has an opening, E, through which air is forced into the annular space, and a vent-cock, F, opening from it.

2. The combination, with pipe C, of the outer pipe G, which extends down the well, having at its lower end a valve, I, and just above this a nozzle, J, and having guides K, also a protecting-pipe, P, with holes, all substantially as shown.

3. The inner pipe C, with the lifting and supporting collars M L, and arranged with the lever N and a spout, O, substantially as described, and for the purposes set forth.

THOS. B. GUNNING.

Witnesses:

THOMAS B. GUNNING, Jr.,
S. B. GOODALE.